

The Voice of Torque Control



TORQUE TOOL AND MEASUREMENT
CATALOGUE - ISSUE 2

2022

GENERIC		
Accuracy (%)	Torque & Angle	Digital Display
Single Scale	Dual Scale	Multi Scale
Calibration Certificate	UKAS Accredited Certification	IP Rated
Bluetooth Enabled	Case Included	

SCREWDRIVERS & TORQUE WRENCHES		
Ratchet	Torque Handle	Fixed
Adjustment Lock	Declaration of Conformance	Calibration Certificate
1/4" Hex Bit Holder		

MANUAL TORQUE MULTIPLIERS		
Adjustable Reaction	Anti Wind-up Ratchet	

POWERED TORQUE TOOLS		
Adjustable Reaction	2 Speed	Air Consumption - litres/sec
Lifting Attachment	Bi-Directional	

TORQUE MEASUREMENT INSTRUMENTS		
Multi Transducers	Back-up Data	

HARSH ENVIRONMENT INSTRUMENTS		
Multi Transducers		

ULTRASONIC MEASUREMENT		
Back-up Data		

- About Norbar - The Voice of Torque Control 2
- Introduction to Torque 3
- Torque Screwdrivers and Torque Wrenches 8
 - ISO 6789:2017 9
 - Torque Screwdrivers 11
 - TT Torque Wrenches 11
 - TTI Non-Magnetic Torque Wrenches 12
 - NorTorque® 13
 - NorTorque® Tethered Torque Wrenches - for working at height 16
 - Slimline™ Torque Wrenches 17
 - Professional Torque Wrenches Model 5 18
 - Professional Torque Wrenches 19
 - Professional 'P' Type Torque Wrenches 23
 - Professional Torque Wrenches NLD Series 25
 - Industrial Torque Wrenches Adjustable & 'P' Type - New Generation 27
 - Industrial Torque Wrench - Bi-Square 29
 - Electrode Wrenches 29
- Electronic Screwdriver and Torque Wrenches 30
 - ProTronic® Electronic Torque Wrenches 31
 - ProTronic® Plus Electronic Torque Wrenches 33
 - ProTronic® Plus Electronic Torque Screwdriver 35
 - ProTronic® Plus Model 10 and Model 30 36
 - ProTronic® Plus TorqApp™ 37
 - NorTronic® Electronic Torque Wrenches 39
- HandTorque® Torque Multipliers 46
 - HandTorque® Torque Multipliers 47
 - Anti Wind-Up Ratchets (AWUR) 49
 - HandTorque® HT3-1000 50
 - HandTorque® HT3 Series 50
 - HandTorque® HT4 Series 51
 - HandTorque® Compact Series 52
 - HandTorque® Compact Series Kits 53
 - HandTorque® Standard Series 53
 - HandTorque® Small Diameter Series 55
 - UKAS Accredited Calibration Certification 55
- Powered Torque Tools 56
 - EvoTorque®2 57
 - EvoTorque® Battery Tool (EBT) 61
 - EvoTorque® 2 & EvoTorque® Battery Tool Right Angle Gearbox 64
 - Pneumatic Torque Tools 65
 - PneuTorque® PTS™ Series 67
 - PneuTorque® PTS™ Right Angle Gearbox 69
 - PneuTorque® PTS™ Remote Series 70
 - PneuTorque® PTM Series 71
 - PneuTorque® PTM Right Angle Gearbox 73
 - PneuTorque® PTME-72 Series 73
 - ET, ET2, PTS™ and PTM Nose Extensions 74
 - PneuTorque® Standard Series 75
 - Torque Reaction 79
 - PTS™ and PTM Dual Trigger Module (DTM) 85
 - Secondary Handle 85
 - Right Angle Gearbox Module 86
 - Lubro Control Units 87
 - Socket Retainers 87
- Torque Measurement 88
- Hydraulic Tool Calibration Fixtures 116
- Tool Controllers 120
- Valve Testing 122
- Harsh Environment Instruments 124
- Engineer to Order 129
- Ultrasonic Measurement 134
- Calibration Beams & Weights 136
- Spares Kits 141
- Calibration Services 145
- Terms & Conditions - September 2021 151



ISO 9001:2015



ENMS 621748



ABOUT NORBAR - THE VOICE OF TORQUE CONTROL

United Kingdom + 44 (0)1295 753600 sales@norbar.com	China + 86 21 6145 0368 sales@norbar.com.cn
USA + 1 866 667 2272 inquiry@norbar.us	Singapore + 65 6841 1371 enquiries@norbar.sg
FASTORQ + 1 281 449 6466 esales@fastorq.com	Australia + 61 (0)8 8292 9777 norbar@norbar.com.au
India + 91 22 2778 8480 enquiry@norbar.in	New Zealand + 64 (0)9 579 8653 norbarnz@norbar.com.au

GLOBAL SERVICE

We are the world’s leading specialist in torque control and we are engaged solely in the design, development and production of torque tightening and measuring equipment.

Our customers include manufacturers and engineering services in such diverse sectors as aerospace, energy, oil and gas, mining and sub-sea.

There are sales and service branches as shown above. In addition, we have distributors of our torque control products in more than 60 countries around the world.

In our 2022 catalogue you will find the recently launched ProTronic® and ProTronic® Plus, a new family of high-precision electronic torque and angle wrenches. You will find full information on these exciting new products, along with details of the partnering Android app for ProTronic® Plus, on pages 31 to 38 and on our website.

We continue to invest in the very latest design, manufacturing and quality control technology to achieve the highest level of innovation and precision in the field of torque control and equipment.

A GLOBAL, LOCAL BUSINESS

From our humble beginnings over 75 years ago, in a small workshop in North Bar, to our latest purpose built factory on Wildmere Road, Norbar has pioneered many of today’s solutions for torque control. Our offices around the world are excellent at taking core Banbury product and developing it for your use in your application. From manual torque wrenches to sophisticated control systems we are still dedicated to being the best at what we do. Norbar is now a member of the Snap-on Incorporated family of companies and is proud to be part of a business which has beliefs, values and a vision closely aligned with those that Norbar was founded on. We still strive to be “The best torque tool company in the world. Respected, profitable and a great place to work.”



We are excited to inform you that the well-regarded brand FASTORQ is now a part of the Norbar family. Based in New Caney, Texas, FASTORQ are a global provider of precision bolt loading and removal solutions and offer a range of products well suited to complement Norbar’s existing product range. FASTORQ are a pioneer in the hydraulic tools industry and today design, manufacture and sell a revolutionary line of bolting solutions and specialty bolting lubricants delivering timely resolutions to bolting challenges of all sizes on land or sea. FASTORQ’s highly skilled team of engineers and bolting technicians have over 100 combined years of bolting knowledge.



INTRODUCTION TO TORQUE

What is Torque?

Torque is any force or system of forces that tends to cause rotation about an axis.

Measurement of Torque

Imagine someone tightening a bolt using a socket attached to a meter (m) long bar. If they apply 10 kg of force (kgf) perpendicular to the bar they will produce a torque of 10 kgf·m at the axis (the centre of the bolt).

However, under the S.I. system of measurement, force is expressed in Newtons (N) rather than kgf. The conversion between kgf and N is x 9.807 so the person is applying 98.07 N·m of torque.

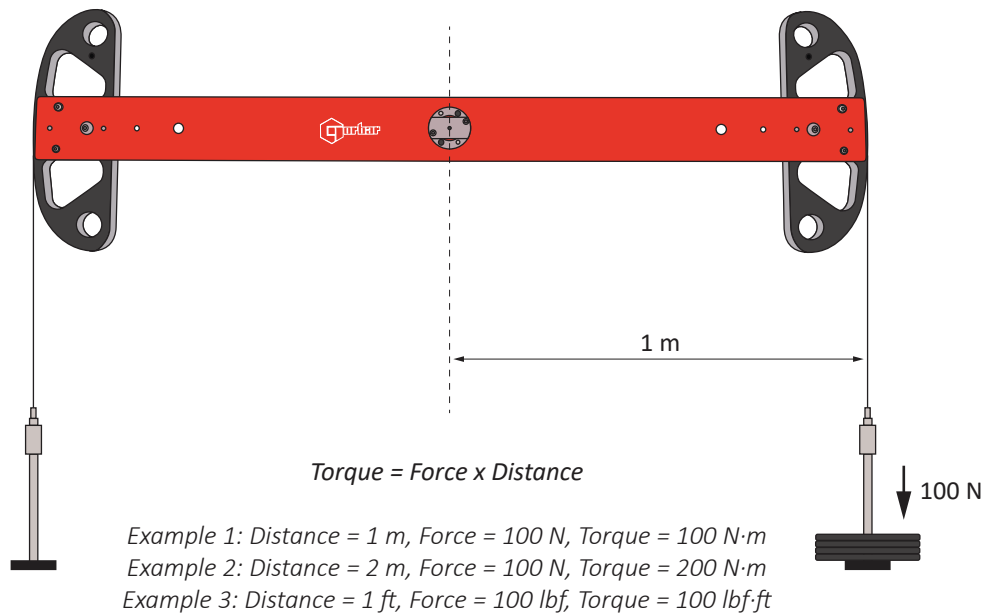

The Importance of Torque Control

Although many methods exist to join two or more parts together, the ease of assembly and disassembly provided by threaded fasteners make them the ideal choice for many applications.

The object of a threaded fastener is to clamp parts together with a tension greater than the external forces tending to separate them. The bolt then remains under constant stress and is immune from fatigue. However, if the initial tension is too low, varying loads act on the bolt and it will quickly fail. If the initial tension is too high, the tightening process may cause bolt failure. Reliability therefore depends upon correct initial tension. The most practical way of ensuring this is by specifying and controlling the tightening torque.

Bolt Tension

When an assembly is clamped by tightening a nut and bolt, the induced tension causes the bolt to stretch. An equal force acts to compress the parts which are thus clamped.

The proof load of a bolt, normally established by test, is the load which just starts to induce permanent set – also known as the yield point. Typically bolts are tightened to between 75% and 90% of yield.

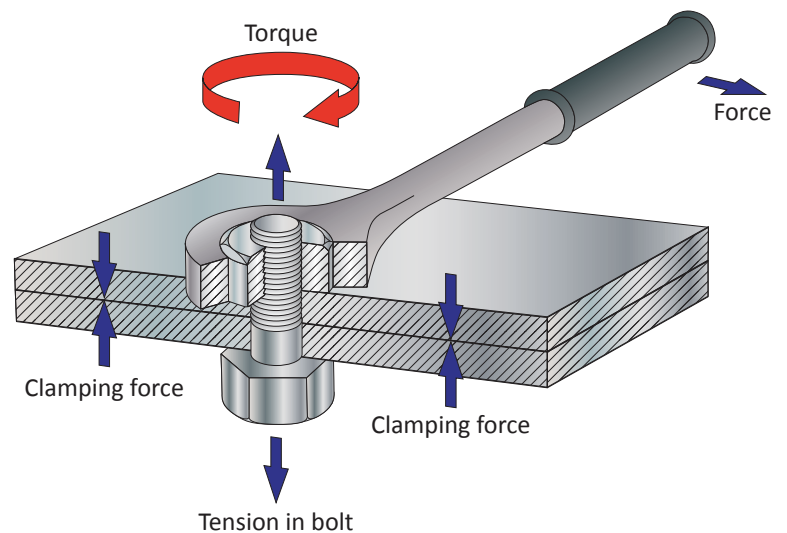



INTRODUCTION TO TORQUE

Friction in the Bolted Joint

When a threaded fastener is tightened, the induced tension results in friction under the head of the bolt and in the threads. It is generally accepted that as much as 50% of the applied torque is expended in overcoming friction between the bolt head and the abutting surface and another 30% to 40% is lost to friction in the threads. As little as 10% of the applied torque results in useful work to tension the bolt.

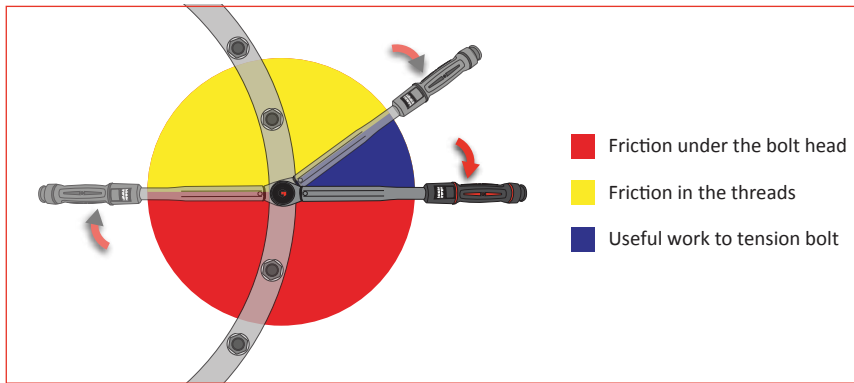

Given that up to 90% of the applied torque will be lost to friction, it follows that any changes in the coefficient of friction resulting from differences in surface finish, surface condition and lubrication can have a dramatic effect on the torque versus tension relationship. Some general points can be made:

- Most torque tightened joints do not use washers because their use can result in relative motion between the nut and washer or the washer and joint surface during tightening. This has the effect of changing the friction radius and hence affects the torque-tension relationship. Where a larger bearing face is required then flange nuts or bolts can be used. If washers are to be used, hard washers with a good fit to the shank of the bolt give lower and more consistent friction and are generally to be preferred.
- Degreasing fasteners of the film of oil usually present on them as supplied will decrease the tension for a given torque and may result in shear of the fastener before the desired tension is achieved.
- Super lubricants formulated from graphite, molybdenum disulphide and waxes result in minimal friction. Unless allowance is made in the specified tightening torque, the induced tension may be excessive causing the bolt to yield and fail. However, used in a controlled manner, these lubricants serve a useful purpose in reducing the torque to produce the desired tension meaning that a lower capacity tightening tool can be used.
- For reasons of appearance or corrosion resistance, fasteners may be plated. These treatments affect the coefficient of friction and therefore the torque versus tension relationship.
- Friction is often deliberately introduced into the fastener to reduce the possibility of loosening due to vibration. Devices such as lock-nuts must be taken into account when establishing the correct tightening torque.

As a rough guide, the calculated tightening torque should be multiplied by the factor from the table below according to surface treatment and lubrication.

		Surface Condition of Bolt			
		Untreated	Zinc	Cadmium	Phosphate
Surface Condition of Nut	Untreated	1.00	1.00	0.80	0.90
	Zinc	1.15	1.20	1.35	1.15
	Cadmium	0.85	0.90	1.20	1.00
	Phosphate and oil	0.70	0.65	0.70	0.75
	Zinc with wax	0.60	0.55	0.65	0.55



INTRODUCTION TO TORQUE

Tightening to Yield

Bolts tightened to yield provide consistently higher preloads from smaller diameter bolts. The reduced fastener stiffness reduces the fatigue loading to which the bolt is subjected under repeated external load reversals, e.g. cylinder heads and connecting rods.

In theory, a bolt tightened to its yield point will provide the strongest and most fatigue-resistant joint possible, within the physical limitations of the bolt material and manufacturing process.

The downside of this method is the cost of the sophisticated equipment necessary to determine when the bolt goes into yield.

Torque Tension Calculator

For further information and guidance on establishing the correct tightening torque for a fastener, see Norbar's web based calculator, www.norbar.com/Support/Calculators/Torque-Tension-Calculator



When Torque Doesn't Equal Tight

As we have established, it is the tension in a fastener rather than the torque that is the critical factor. Torque is an indirect means of establishing tension and in a correctly engineered joint and with a controlled tightening process, it is a satisfactory method under the majority of circumstances.

However, in joints that are highly critical due to safety or the cost and implications of machine down-time, a more direct means of establishing tension is needed. Various methods exist including several types of load indicating bolts or washers. However, one of the most versatile methods is to measure the extension of the bolt due to the tightening process using ultrasound.

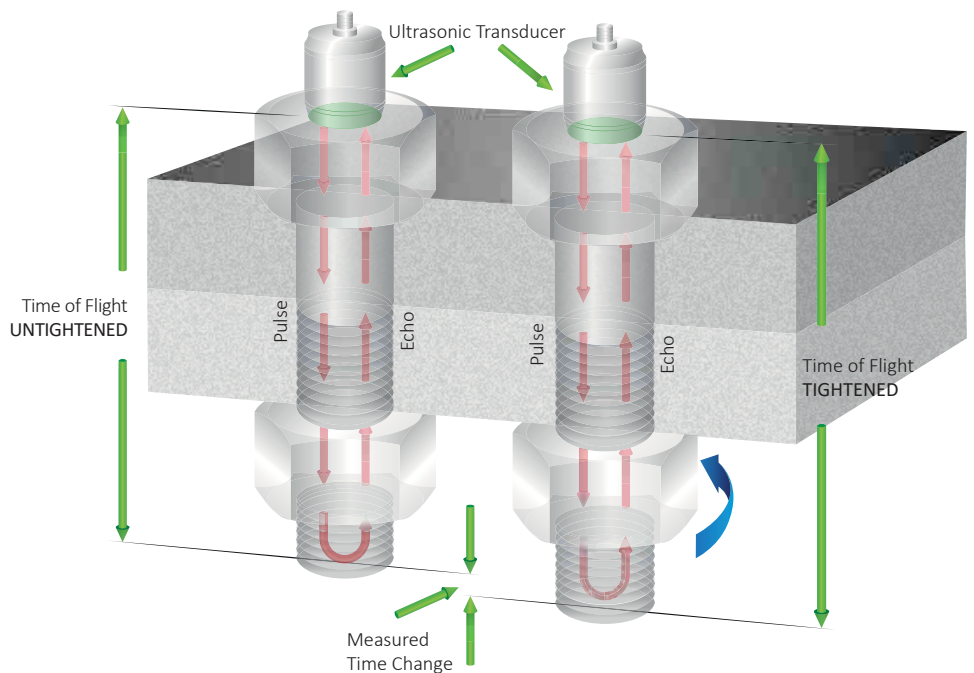





INTRODUCTION TO TORQUE

Recommended Maximum Torque Values

The information supplied here is intended to be an acceptable guide for normal conditions. For critical applications, further information and research will be necessary. The following basic assumptions have been made:

- a. Bolts are new, standard finish, uncoated and not lubricated (other than the normal protective oil film)
- b. The load will be 90% of the bolt yield strength
- c. The coefficient of friction is 0.14
- d. The final tightening sequence is achieved smoothly and slowly

If lubrication is to be applied to the nut/bolt, multiply the recommended torque by the appropriate factor shown in the table on page 4. Alternatively, use the Torque/Tension Calculator on the Norbar website (shown on page 5) which enables fastener and friction conditions to be modified with ease.

 M	BOLT GRADE									 mm
	3.6	4.6	5.6	5.8	6.8	8.8	9.8	10.9	12.9	
	Torque in N·m									
M 1.6	0.05	0.07	0.09	0.11	0.14	0.18	0.21	0.26	0.31	3.2
M 2	0.11	0.14	0.18	0.24	0.28	0.38	0.42	0.53	0.63	4
M 2.5	0.22	0.29	0.36	0.48	0.58	0.78	0.87	1.09	1.31	5
M 3	0.38	0.51	0.63	0.84	1.01	1.35	1.52	1.9	2.27	5.5
M 4	0.71	0.95	1.19	1.59	1.91	2.54	2.86	3.57	4.29	7
M 5	1.71	2.28	2.85	3.8	4.56	6.09	6.85	8.56	10.3	8
M 6	2.94	3.92	4.91	6.54	7.85	10.5	11.8	14.7	17.7	10
M 8	7.11	9.48	11.9	15.8	19	25.3	28.4	35.5	42.7	13
M 10	14.3	19.1	23.8	31.8	38.1	50.8	57.2	71.5	85.8	17
M 12	24.4	32.6	40.7	54.3	65.1	86.9	97.9	122	147	19
M 14	39	52	65	86.6	104	139	156	195	234	22
M 16	59.9	79.9	99.8	133	160	213	240	299	359	24
M 18	82.5	110	138	183	220	293	330	413	495	27
M 20	117	156	195	260	312	416	468	585	702	30
M 22	158	211	264	352	422	563	634	792	950	32
M 24	202	270	337	449	539	719	809	1,011	1,213	36
M 27	298	398	497	663	795	1,060	1,193	1,491	1,789	41
M 30	405	540	675	900	1,080	1,440	1,620	2,025	2,430	46
M 33	550	734	917	1,223	1,467	1,956	2,201	2,751	3,301	50
M 36	708	944	1,180	1,573	1,888	2,517	2,832	3,540	4,248	55
M 39	919	1,226	1,532	2,043	2,452	3,269	3,678	4,597	5,517	60
M 42	1,139	1,518	1,898	2,530	3,036	4,049	4,555	5,693	6,832	65
M 45	1,425	1,900	2,375	3,167	3,800	5,067	5,701	7,126	8,551	70
M 48	1,716	2,288	2,860	3,813	4,576	6,101	6,864	8,580	10,296	75
M 52	2,210	2,947	3,684	4,912	5,895	7,859	8,842	11,052	13,263	80
M 56	2,737	3,650	4,562	6,083	7,300	9,733	10,950	13,687	16,425	85
M 60	3,404	4,538	5,673	7,564	9,076	12,102	13,614	17,018	20,422	90
M 64	4,100	5,466	6,833	9,110	10,932	14,576	16,398	20,498	24,597	95
M 68	4,963	6,617	8,271	11,029	13,234	17,646	19,851	24,814	29,777	100



INTRODUCTION TO TORQUE

Torque Conversion Factors

Units to be converted	S.I. Units		Imperial Units			Metric Units	
	cN·m	N·m	ozf·in	lbf·in	lbf·ft	kgf·cm	kgf·m
1 cN·m =	1	0.01	1.416	0.088	0.007	0.102	0.001
1 N·m =	100	1	141.6	8.851	0.738	10.20	0.102
1 ozf·in =	0.706	0.007	1	0.0625	0.005	0.072	0.0007
1 lbf·in =	11.3	0.113	16	1	0.083	1.152	0.0115
1 lbf·ft =	135.6	1.356	192	12	1	13.83	0.138
1 kgf·cm =	9.807	0.098	13.89	0.868	0.072	1	0.01
1 kgf·m =	980.7	9.807	1389	86.8	7.233	100	1

FORCE

$$\text{lbf} \times 4.45 = \text{N}$$

$$\text{N} \times 0.225 = \text{lbf}$$

FLOW

$$\text{l/s} \times 2.119 = \text{cu-ft/min}$$

$$\text{cu-ft/min} \times 0.472 = \text{l/s}$$

PRESSURE

$$\text{lbf/in}^2 \times 0.069 = \text{bar}$$

$$\text{bar} \times 14.504 = \text{lbf/in}^2$$

POWER

$$\text{hp} \times 0.746 = \text{kW}$$

$$\text{kW} = \frac{\text{N}\cdot\text{m} \times \text{rev/min}}{9,546}$$

Formulae

Accepted formulae relating torque and tension, based on many tests are:-

For Imperial Sizes

$$M = \frac{P \times D}{60}$$

M = torque lbf·ft
P = bolt tension lbf
D = bolt diameter (ins)

For Metric Sizes

$$M = \frac{P \times D}{5000}$$

M = torque N·m
P = bolt tension Newtons
D = bolt diameter (mm)

These formulae may be used for bolts outside the range of the tables.

Formula for Calculating the Effect of Torque Wrench Extensions

$$M1 = M2 \times L1/L2$$

Where L1 is the normal length and L2 is the extended length, M1 is the set torque and M2 the actual torque applied to the nut.

Example

The required torque on the fastener is 130 N·m (M2) but what do you set on the torque wrench scale?

$$L1 = 500 \quad L2 = 650$$

(units of length not important, this is ratio)

$$M1 = 130 \times 500/650$$

$$M1 = 100$$

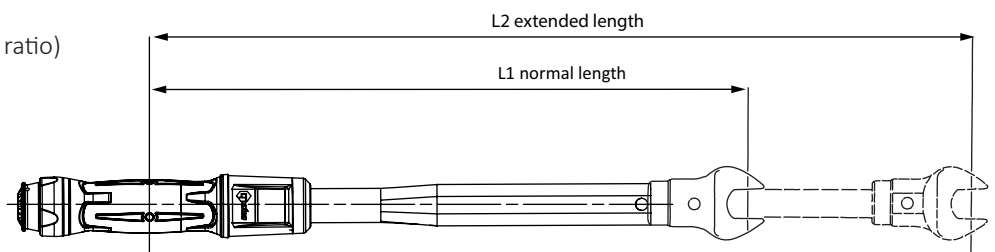

For further information and guidance on converting torque and calculating the effect of torque wrench extensions download our purpose-built applications for iPhone and Android.



TORQUE SCREWDRIVERS AND TORQUE WRENCHES

Norbar Torque Tools manufacture an extensive range of high quality torque screwdrivers and torque wrenches to cover torque values from 0.3 N·m to 2,000 N·m. They are designed and manufactured to exceed international standards for accuracy.

In addition to the normal 'adjustable' torque wrenches, Norbar offer Production 'P' Type versions which can be pre-set and dedicated to a particular application. This setting system is designed to discourage unauthorised alteration.

All Norbar torque wrenches are offered as standard with a quality ratchet. For applications where interchangeable end fittings are required, 'Torque Handles' which allow for interchangeable spanner fittings, are also available in various models up to 650 N·m.

ISO 6789:2017	9
Torque Screwdrivers	11
TT Torque Wrenches	11
TTi Non-Magnetic Torque Wrenches	12
NorTorque®	13
NorTorque® Tethered Torque Wrenches - for working at height	16
Slimline™ Torque Wrenches	17
Professional Torque Wrenches Model 5	18
Professional Torque Wrenches	19
Professional 'P' Type Torque Wrenches	23
Professional Torque Wrenches NLD Series	25
Industrial Torque Wrenches Adjustable & 'P' Type - New Generation	27
Industrial Torque Wrench - Bi-Square	29
Electrode Wrenches	29
Spanner End Fittings for 16 mm Torque Handles	41
Spanner End Fittings for 22 mm Torque Handles	42
Spigot Accessories	42
Large Spanner End Fittings for 16 mm Spigot Torque Handles up to 300 N·m	43
Large Spanner End Fittings for 22 mm Spigot Torque Handles up to 650 N·m	44
UKAS Accredited Calibration Certification	45





Since 1993, ISO 6789 has been the international standard for “Assembly tools for screws and nuts – hand torque tools”. The standard now covers a range of topics guiding the design, marking, conformance testing and calibration of hand torque tools. As such, it is a key reference document for torque wrench manufacturers and those re-calibrating torque wrenches in the after sales market. While it is not primarily aimed at torque tool users, some users may benefit from understanding the parameters that torque wrench manufacturers are working to and the standard will be necessary for larger users carrying out their own, in-house testing or calibration.



Norbar's UKAS accredited laboratory has been working to the new standard since September 2017 and was the first laboratory to do so.

What has changed?

The 2003 edition was itself a development of the 1993 edition. The 2003 standard divided requirements into three sections of: design conformance testing; quality conformance testing and recalibration. The intention was to allow different groups of users to identify the relevant clauses for their needs.

The 2017 edition takes this logic even further and divides the standard into two distinct parts:

Part 1 still provides requirements for design and quality control during manufacture, it also provides specifications for documenting conformance of hand torque tools. This documentation is referred to as a declaration of conformance because it is stating that the torque tool conforms to the requirements of the standard.

Part 2 defines the requirements for calibration of torque tools including the establishment of uncertainty budgets and the content of certificates of calibration.

Calibration is defined by ISO as: “a set of operations that establish, under specified conditions, the relationship between values of quantities indicated by a measuring instrument or measuring system ... and the corresponding values realised by standards.”

Calibration does not include adjustment or imply conformance, it provides information for the user to assess and act upon.

Why make it more complex?

The standard is splitting into two parts because it has been recognised that torque tool calibration requirements have moved on since the standard was last published in 2003.

The two new parts can be described as one part which follows closely to the 2003 standard and one part which provides a consistent framework for calibrating a hand torque tool to the level that exists in accredited calibration laboratories across the world. The titles of the standards help clarify the difference.

EN ISO 6789-1:2017 (Part 1): Requirements and Methods for design conformance testing and quality conformance testing- Minimum requirements for declaration of conformance.

The quality conformance testing performed under Part 1 is the testing performed on a new torque tool during manufacture. The document that manufacturers will now deliver is a declaration of conformance rather than a calibration certificate. This is because the manufacturer is declaring that the tool conforms to the standard.

EN ISO 6789-2:2017 (Part 2): Requirements for calibration and determination of measurement uncertainty.

The calibration performed under Part 2 is a traceable calibration including steps to understand the factors for that particular torque tool that might cause the calibration values to vary from calibration to calibration. Any UKAS accredited laboratory in the United Kingdom, or indeed any laboratory accredited to ISO 17025 by an appropriate organisation, will be required to establish the uncertainty by conducting these steps. A model of torque tool that the laboratory has not seen before would take about 60 minutes to calibrate to the new standard.



ISO 6789-1:2017 (Part 1)
Feature Icon



ISO 6789-2:2017 (Part 2)
Feature Icon



ISO 6789:2017

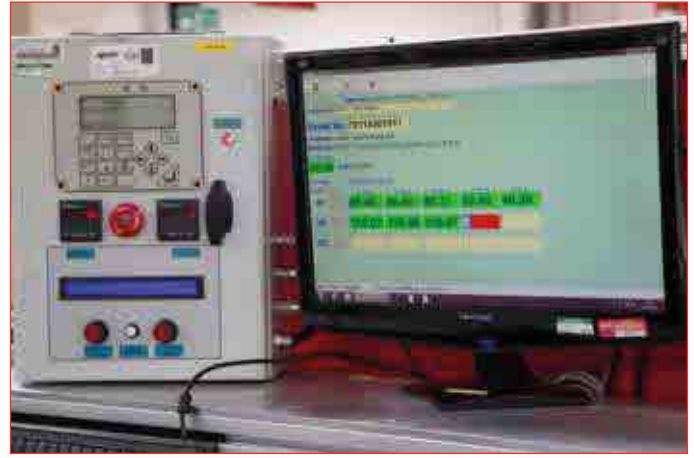

How does it affect a torque tool user?

If a current end user was previously content to buy a new torque tool and put it into service on the basis of the calibration certificate supplied with the tool by the manufacturer, then they can continue to do so after the standard changes, even though the new piece of paper is now called a declaration of conformance.

If the end user's quality control processes currently require a traceable calibration certificate issued by an accredited laboratory then they will already not accept the current manufacturer's document but will be paying for a calibration in an accredited laboratory.

If the end user is currently happy with the manufacturer's document for a new tool, then a periodic assessment from their in-house facility or from a sub-contractor should provide an equivalent level of confidence in the performance of the tool. Under the new Part 1 these sub-contractors will be able to continue that work as long as they observe the new changes, but they will not be able to call it a calibration and will not be able to issue a calibration certificate. They will be able to issue a declaration of conformance.

In essence, one of the key changes in the standard is to protect the use of the term calibration. It will initially be confusing to both end users and service providers, but the International Standards Organisation has clear definitions of words such as calibration and we will have to adapt our thinking to conform.

Torque Wrench Calibrator (TWC)

To help our customers meet the requirements of this new standard we have launched the TWC Auto which enables torque wrench calibration or testing in accordance with ISO 6789-2:2017. Further details can be found on page 111.



Torque Wrench Calibrator (TWC) Auto shown with a Professional Model 200 and a Static Transducer with support kit (not included)



Further Information

Further information on the new standard can be found on our website through the following link:

www.norbar.com/Quality/ISO-6789

If you have any questions specifically on the new standard please make contact with us here:

ISO6789@norbar.com



TORQUE SCREWDRIVERS



Versatile, accurate and easy torquing for smaller fasteners and restricted spaces

- Accuracy to $\pm 6\%$ meets the requirements of ISO 6789-1:2017
- Supplied with 1/4" hexagon bit holder
- Single scale, either N·m or lbf·in

NOTE: Bit set is only sold separately or as part of kit - see website for bit set details

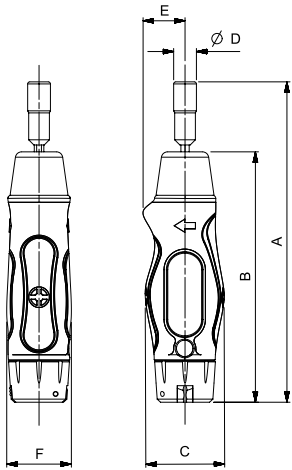

MODEL	ALL MODELS	
Dimensions (mm)	A	155
	B	121
	C	38
	∅D	11
	E	20
	F	31
Weight (kg)	0.2	

2 ADJUSTABLE N·m

13850	TTs1.5, 1/4", 0.3 - 1.5 N·m
13851	TTs3.0, 1/4", 0.6 - 3 N·m
13852	TTs6.0, 1/4", 1.2 - 6 N·m

2 ADJUSTABLE lbf·in

13853	TTs13, 1/4", 2.5 - 13 lbf·in
13854	TTs26, 1/4", 5 - 26 lbf·in
13855	TTs53, 1/4", 10 - 53 lbf·in

2 PRODUCTION 'P' TYPE

13856	TTs1.5, 1/4", 0.3 - 1.5 N·m, 2.5 - 13 lbf·in
13857	TTs3.0, 1/4", 0.6 - 3 N·m, 5 - 26 lbf·in
13858	TTs6.0, 1/4", 1.2 - 6 N·m, 10 - 53 lbf·in
SQ2222	Pre-set, etch and certify (Allow 3 days delivery for this service)

2 ADJUSTABLE N·m KIT

13700	TTs0.3 - 1.5 N·m Kit with 12 piece bit set and case
13701	TTs0.6 - 3 N·m Kit with 12 piece bit set and case
13702	TTs1.2 - 6 N·m Kit with 12 piece bit set and case
28937	12 Piece 1/4", Hex bit set

TT TORQUE WRENCHES



For no-nonsense torquing - comfortable, accurate and easy to use

- Accurate to $\pm 3\%$ of reading which meets the requirements of ISO 6789-1:2017
- Micrometer scale for simple and error free setting
- All models feature a lock to prevent accidental adjustment of the set torque
- Handle and lens materials resistant to commonly used industrial chemicals



TTi Reversible Ratchet



TTf Fixed Head



TTfth Torque Handle

2 RATCHET ADJUSTABLE - DUAL SCALE

13830	TTi20, 1/4", 4 - 20 N·m, 35 - 180 lbf·in
13831	TTi20, 3/8", 4 - 20 N·m, 35 - 180 lbf·in
13841	TTi50, 3/8", 10 - 50 N·m, 8 - 35 lbf·ft
13842	TTi50, 1/2", 10 - 50 N·m, 8 - 35 lbf·ft

2 RATCHET ADJUSTABLE - N·m ONLY

13832	TTi20, 1/4", 4 - 20 N·m
13833	TTi20, 3/8", 4 - 20 N·m
13843	TTi50, 3/8", 10 - 50 N·m
13844	TTi50, 1/2", 10 - 50 N·m

2 RATCHET ADJUSTABLE - lbf·ft ONLY

13834	TTi15, 1/4", 35 - 180 lbf·in
13835	TTi15, 3/8", 35 - 180 lbf·in
13845	TTi35, 3/8", 8 - 35 lbf·ft
13846	TTi35, 1/2", 8 - 35 lbf·ft

2 FIXED HEAD ADJUSTABLE

13836	TTf 20, 3/8", 4 - 20 N·m, 35 - 180 lbf·in
13837	TTf 20, 3/8", 4 - 20 N·m (N·m ONLY)
13838	TTf 15, 3/8", 35 - 180 lbf·in (lbf·in ONLY)

2 FEMALE TORQUE HANDLE ADJUSTABLE

13839	TTfth 20, 9 x 12 mm, 4 - 20 N·m, 35 - 180 lbf·in
13847	TTfth 50, 9 x 12 mm, 10 - 50 N·m, 8 - 35 lbf·ft
13840	TTfth 20, 9 x 12 mm, 4 - 20 N·m (N·m ONLY)
13848	TTfth 50, 9 x 12 mm, 10 - 50 N·m (N·m ONLY)



TTI NON-MAGNETIC TORQUE WRENCHES



Carefully selected and tested materials replace the ferrous components present in standard torque wrenches, thereby giving an extremely low magnetic footprint. Being based on the TT range of torque wrenches means that they also retain the high standards of Norbar's other torque wrenches. Perfect for MRI scanner applications.

4		ADJUSTABLE - DUAL SCALE
13900	TTi20, 3/8" Non-Mag, 4 - 20 N·m, 35 - 180 lbf-in	
13901	TTi20, 1/2" Non-Mag, 4 - 20 N·m, 35 - 180 lbf-in	
13902	TTi50, 3/8" Non-Mag, 10 - 50 N·m, 8 - 35 lbf-ft	
13903	TTi50, 1/2" Non-Mag, 10 - 50 N·m, 8 - 35 lbf-ft	

4		ADJUSTABLE - N·m ONLY
130503	TTi20, 3/8" Non-Mag, 3 - 20 N·m	
130504	TTi20, 1/2" Non-Mag, 3 - 20 N·m	
13906	TTi50, 3/8" Non-Mag, 10 - 50 N·m	
13907	TTi50, 1/2" Non-Mag, 10 - 50 N·m	

TTi Ratchet / Non-Magnetic

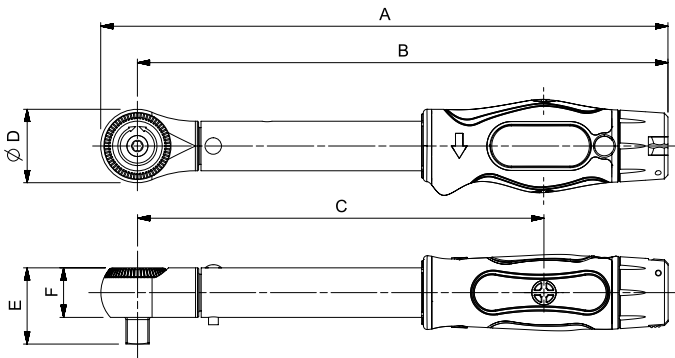

Model	TT Torque Wrenches / Non-Magnetic					
	TTi20 TTi15	TTi50 TTi35	TTf20 TTf15	TTfth20	TTfth50	
Part Number	13830, 13831, 13832, 13833, 13834, 13835, 13900, 13901, 130503, 130504	13841, 13842, 13843, 13844, 13845, 13846, 13902, 13903, 13906, 13907	13836, 13837, 13838	13839, 13840	13847, 13848	
Dimensions (mm)	A	232	328	225	214	310
	B	217	313	217	204	300
	C	166	263	166	153	250
	∅D	30	30	20	22	22
	E	31	31	28	17	17
	F	20	20	18	N/A	N/A
Weight (kg)	0.5	0.7	0.5	0.4	0.6	

TTf Fixed Head

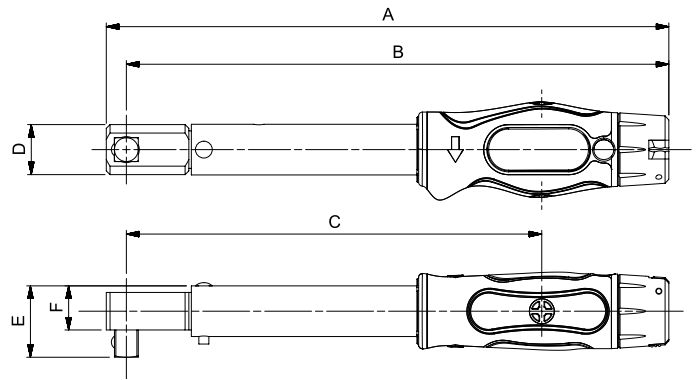

TTfth Female Torque Handle

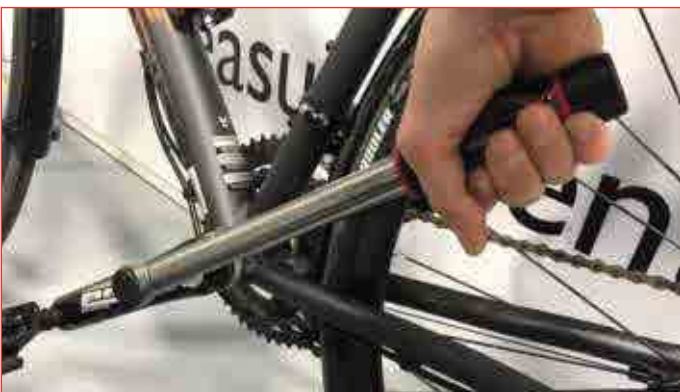
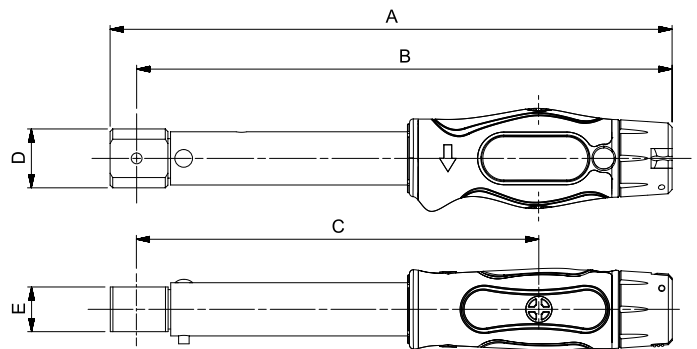

TTi50 tightening a pedal crank of a bicycle



TTi20 Non-Magnetic in application on an MRI Scanner



NORTORQUE®



The NorTorque® utilises Norbar’s proven mechanism and internal components and incorporates them into a purposeful and attractive torque wrench that will delight a wide range of users from professional mechanics to hobby enthusiasts

- Accurate to $\pm 3\%$ of reading which meets the requirements of ISO 6789-1:2017
- Light and fast adjustment saves operator time and effort
- Micrometer scale applying to the primary torque units (N·m on a dual scale wrench) for simple and error-free setting
- ‘Push-through’ ratchets allow torque control in both the clockwise and counter-clockwise directions
- Tough ratchets with narrow engagement angles allow for easy positioning of the tool in confined spaces (5° for models up to 200 N·m and 6° for models 300 N·m and above)
- Push/pull lock is fast and intuitive to use and prevents accidental adjustment of the set torque
- Convenient hanger feature for tool storage also aids wrench unlocking and adjustment
- Tethered versions are available for working at height (see page 16)

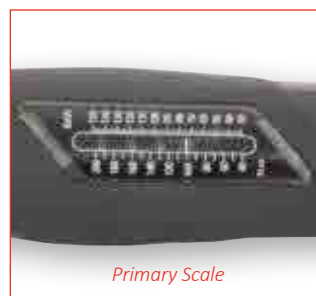

Primary Scale



Micrometer Scale

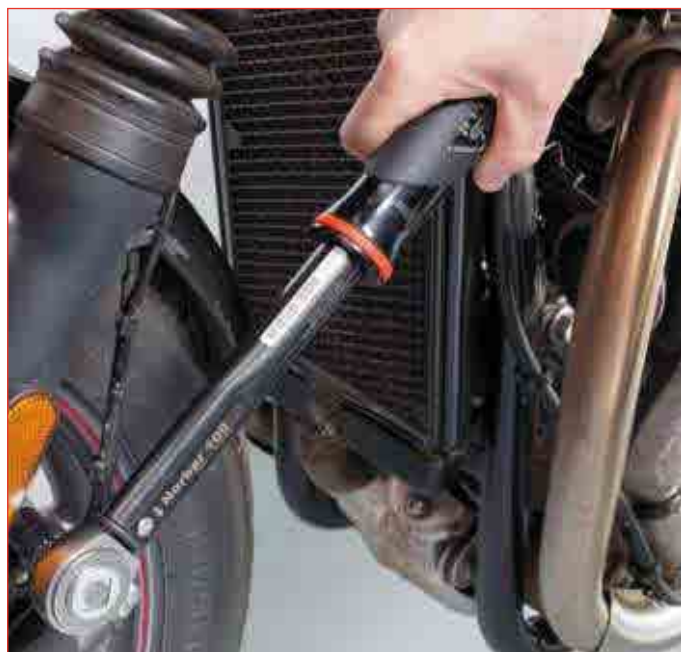

Push-Through Ratchet



Female Torque Handle



16 mm Spigot End



2 RATCHET ADJUSTABLE - DUAL SCALE

130101*	Model 60, 3/8", 12 - 60 N·m, 10 - 45 lbf·ft
130103*	Model 100, 1/2", 20 - 100 N·m, 20 - 80 lbf·ft
130104	Model 200, 1/2", 40 - 200 N·m, 30 - 150 lbf·ft
130105	Model 300, 1/2", 60 - 300 N·m, 45 - 220 lbf·ft
130106	Model 340, 1/2", 60 - 340 N·m, 45 - 250 lbf·ft

2 RATCHET ADJUSTABLE - N·m ONLY

130111*	Model 60, 3/8", 12 - 60 N·m
130113*	Model 100, 1/2", 20 - 100 N·m
130114	Model 200, 1/2", 40 - 200 N·m
130115	Model 300, 1/2", 60 - 300 N·m
130116	Model 340, 1/2", 60 - 340 N·m

* Supplied with 1/2" sq. dr. adaptor

· Supplied with 3/8" sq. dr. adaptor



2 FEMALE TORQUE HANDLE ADJUSTABLE - DUAL SCALE

130121	Model 60, 9 x 12 mm, 12 - 60 N·m, 10 - 45 lbf·ft
130123	Model 100, 9 x 12 mm, 20 - 100 N·m, 20 - 80 lbf·ft
130125	Model 200, 9 x 12 mm, 40 - 200 N·m, 30 - 150 lbf·ft
130126	Model 200, 14 x 18 mm, 40 - 200 N·m, 30 - 150 lbf·ft
130127	Model 300, 14 x 18 mm, 60 - 300 N·m, 45 - 220 lbf·ft
130128	Model 340, 14 x 18 mm, 60 - 340 N·m, 45 - 250 lbf·ft

2 FEMALE TORQUE HANDLE ADJUSTABLE - N·m ONLY

130131	Model 60, 9 x 12 mm, 12 - 60 N·m
130133	Model 100, 9 x 12 mm, 20 - 100 N·m
130135	Model 200, 9 x 12 mm, 40 - 200 N·m
130136	Model 200, 14 x 18 mm, 40 - 200 N·m
130137	Model 300, 14 x 18 mm, 60 - 300 N·m
130138	Model 340, 14 x 18 mm, 60 - 340 N·m



2 TORQUE HANDLE ADJUSTABLE 16 mm SPIGOT - DUAL SCALE

130141	Model 60, 16 mm spigot, 12 - 60 N·m, 10 - 45 lbf·ft
130142	Model 100, 16 mm spigot, 20 - 100 N·m, 20 - 80 lbf·ft
130143	Model 200, 16 mm spigot, 40 - 200 N·m, 30 - 150 lbf·ft
130144	Model 300, 16 mm spigot, 60 - 300 N·m, 45 - 220 lbf·ft

2 TORQUE HANDLE ADJUSTABLE 16 mm SPIGOT - N·m ONLY

130161	Model 60, 16 mm spigot, 12 - 60 N·m
130162	Model 100, 16 mm spigot, 20 - 100 N·m
130163	Model 200, 16 mm spigot, 40 - 200 N·m
130164	Model 300, 16 mm spigot, 60 - 300 N·m



NORTORQUE®



Ratchet Adjustable

Model	NorTorque 60	NorTorque 100	NorTorque 200	NorTorque 300	NorTorque 340	
Part Number	130101 130111	130103 130113	130104 130114	130105 130115	130106 130116	
Dimensions (mm)	A	328	375	459	587	679
	B	310	354	437	562	654
	C	209	252	335	460	552
	ØD	36	42	45	52	52
	E	34	38	45	45	45
	F	21	22	25	25	25
Weight (kg)	0.7	0.8	1.0	1.4	1.6	

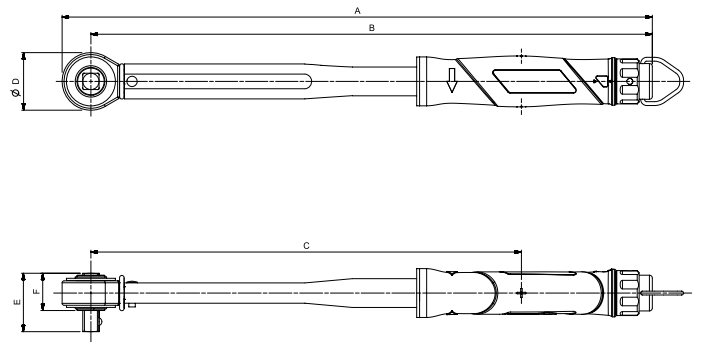

Female Torque Handle Adjustable

Model	NorTorque 60 9 x 12 mm	NorTorque 100 9 x 12 mm	NorTorque 200 9 x 12 mm	NorTorque 200 14 x 18 mm	NorTorque 300 14 x 18 mm	NorTorque 340 14 x 18 mm
Part Number	130121 130131	130123 130133	130125 130135	130126 130136	130127 130137	130128 130138
Dimensions (mm)	A	319	360	437	446	566
	B	308	348	426	430	550
	C	206	247	324	329	448
	D	22	22	24	33	36
	E	20	20	20	25	28
Weight (kg)	0.6	0.7	0.8	0.9	1.2	1.3

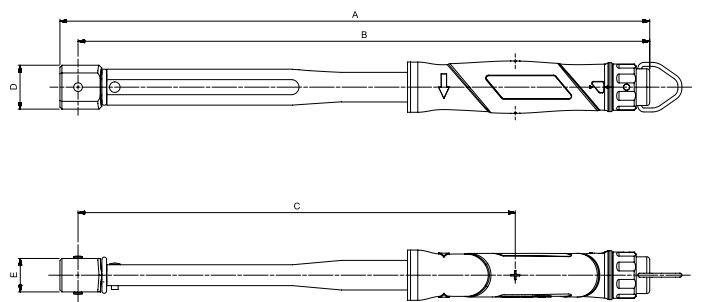

Torque Handle Adjustable 16 mm Spigot

Model	NorTorque 60	NorTorque 100	NorTorque 200	NorTorque 300	
Part Number	130141 130161	130142 130162	130143 130163	130144 130164	
Dimensions (mm)	A	317	357	439	564
	B	310	350	433	557
	C	208	248	331	455
	ØD	16	16	16	16
Weight (kg)	0.6	0.7	0.8	1.1	

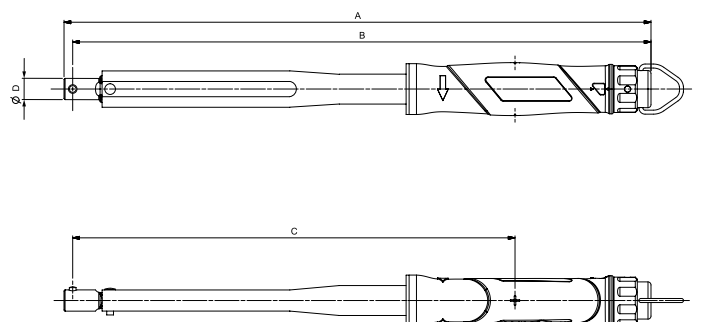



NORTORQUE® TETHERED TORQUE WRENCHES - FOR WORKING AT HEIGHT

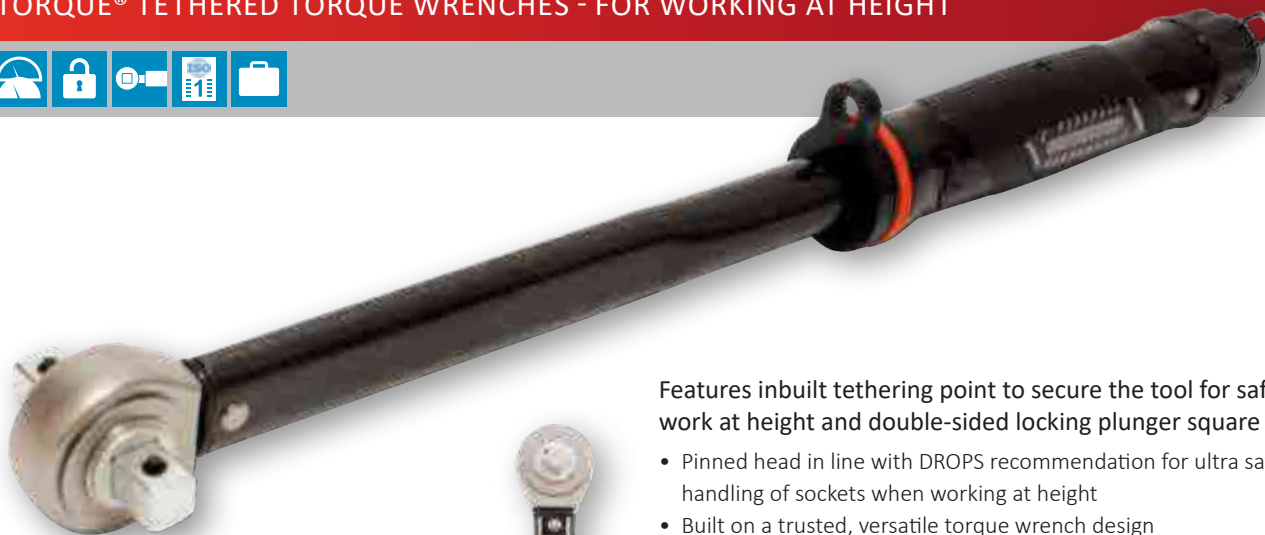

Features inbuilt tethering point to secure the tool for safe work at height and double-sided locking plunger square

- Pinned head in line with DROPS recommendation for ultra safe handling of sockets when working at height
- Built on a trusted, versatile torque wrench design
- Accurate to ±3% of reading which meets the requirements of ISO 6789-1:2017
- Light and fast adjustment saves operator time and effort
- Micrometer scale for simple and error free setting
- Lock feature helps prevent accidental adjustment of the set torque
- Convenient hanger feature for tool storage also aids wrench unlocking and adjustment



Tethering Point



Double-Sided Locking Plunger Square



2	RATCHET ADJUSTABLE - DUAL SCALE
130178	Model 100, ½", 20 - 100 N·m, 20 - 80 lbf·ft
130179	Model 200, ½", 40 - 200 N·m, 30 - 150 lbf·ft
130180	Model 300, ½", 60 - 300 N·m, 45 - 220 lbf·ft

Model	NorTorque Tethered Torque Wrenches			
	Model 100	Model 200	Model 300	
Part Number	130178	130179	130180	
Dimensions (mm)	A	375	459	589
	B	354	437	562
	C	252	335	460
	∅D	42	45	54
	E	53	59	59
	F	22	28	28
	G	16	16	16
Weight (kg)	0.9	1.1	1.5	

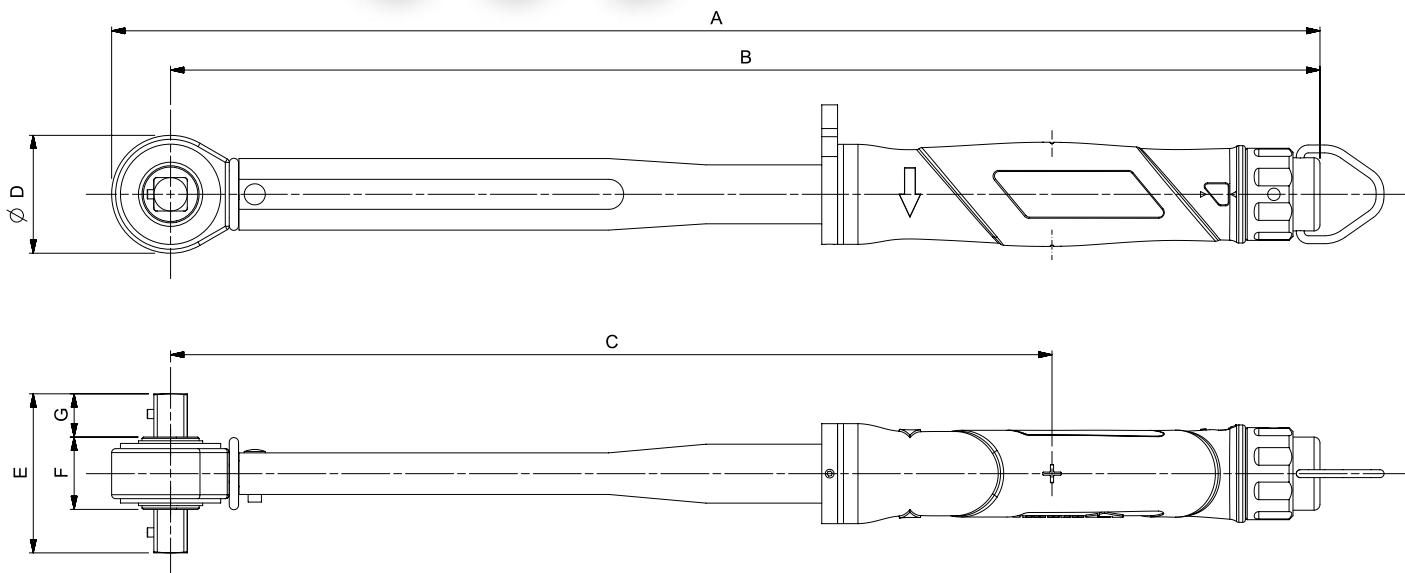



SLIMLINE™ TORQUE WRENCHES



- Accurate to ±3% of reading which meets the requirements of ISO 6789-1:2017
- Unmistakable signal when set torque is reached
- High quality 72 tooth ratchet allows use in confined spaces
- Fixed head version has a push-through square for left and right handed torque tightening
- Moulded grip aids correct hand location and operator comfort

2 ADJUSTABLE RATCHET - DUAL SCALE

11123	SLO, ¼", 4 - 20 N·m, 40 - 180 lbf·in
11087	SLO, ⅜", 4 - 20 N·m, 40 - 180 lbf·in



2 ADJUSTABLE - FIXED HEAD - DUAL SCALE

11125	SLO, ⅜" Fixed Head, 4 - 20 N·m, 40 - 180 lbf·in
-------	-------------------------------------------------



2 TORQUE HANDLE ADJUSTABLE - DUAL SCALE

11126	SLO 16 mm spigot, 4 - 20 N·m, 40 - 180 lbf·in
11122	SLO 9 x 12 mm female, 4 - 20 N·m, 40 - 180 lbf·in



Production 'P' type versions are designed to discourage unauthorised alteration. They have no scale and so must be set against a torque measuring device such as Norbar's TruCheck™ 2 - see page 90.

2 PRODUCTION 'P' TYPE
(Must be set using a Torque Tester, see pages 90 - 97)

11089	SLO, ⅜" Fixed Head, 1 - 20 N·m, 10 - 180 lbf·in
11085	SLO, ¼", 1 - 20 N·m, 10 - 180 lbf·in
11086	SLO, ⅜", 1 - 20 N·m, 10 - 180 lbf·in
11090	SLO, 16 mm spigot, 1 - 20 N·m, 10 - 180 lbf·in
11088	SLO, 9 x 12 mm female, 1 - 20 N·m, 10 - 180 lbf·in
SQ2222	Pre-set, etch and certify (Allow 3 days delivery for this service)

SLO Ratchet

Model	SLO ¼"	SLO ⅜"
Part Number	11123 11085	11087 11086
Dimensions (mm)	A	219
	B	204
	C	146
	ØD	30
	E	26
	F	19
Weight (kg)	0.4	0.4

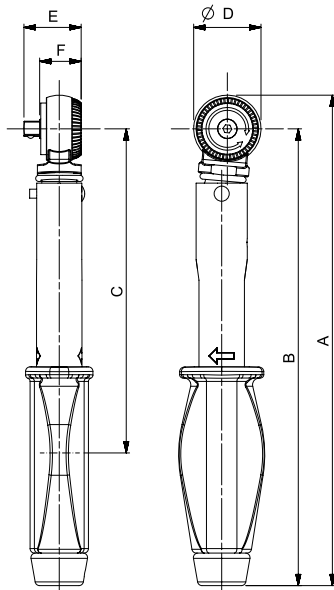

SLO Spigot Torque Handle

Model	SLO Spigot	
Part Number	11126 11090	
Dimensions (mm)	A	206
	B	199
	C	143
	ØD	16
Weight (kg)	0.4	

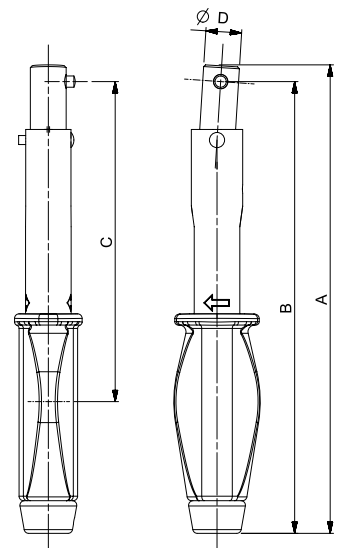



SLIMLINE™ TORQUE WRENCHES



SLO Fixed Head

Model	SLO 3/8" Fixed Head
Part Number	11125 11089
Dimensions (mm)	A 213
	B 203
	C 145
	D 19
	E 30
	F 17
Weight (kg)	0.4

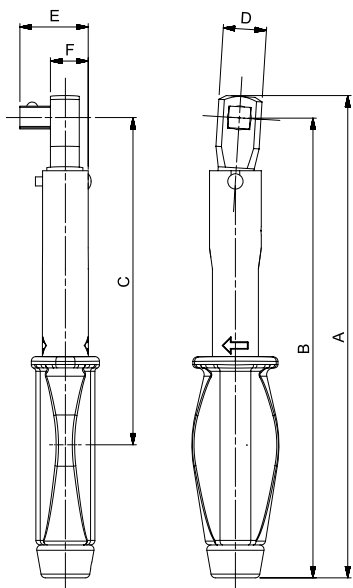

SLO Female Torque Handle

Model	SLO FTH
Part Number	11122 11088
Dimensions (mm)	A 205
	B 194
	C 135
	D 22
	E 20
Weight (kg)	0.4

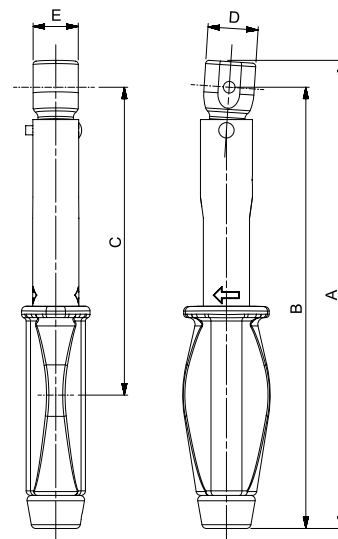

PROFESSIONAL TORQUE WRENCHES MODEL 5



The Model 5 is a unique torque wrench that offers the convenience of interchangeable 1/4" hexagon bits. (ISO 1173:2001 Form C drive bits).

- Accuracy meets the requirements of ISO 6789-1:2017
- Non-length dependent. The Model 5 remains accurate regardless of hand position
- Supplied in a storage case. The case allows space for the storage of additional drive bits

Also available as Production 'P' Types, preventing unauthorised alteration of torque setting. No external calibration equipment is required to set the Model 5 'P' Type.

2	ADJUSTABLE
13001	Pro 5, 1/4" female hex, 1 - 5 N·m
13002	Pro 5, 1/4" female hex, 10 - 50 lbf·in
13003	Pro 5, 1/4" female hex, 10 - 50 kgf·cm

8	MODEL 5 SPARES
28900	1/4" Hex to 1/4" male square drive

Model	Adjustable	'P' Type
Part Number	13001 13002 13003	13004 13005 13006
Dimensions (mm)	A 165	157
	B 155	147
	C 102	102
	D 18	18
	E 25	25
	F 13	13
	G 2.8	2.8
Weight (kg)	0.1	0.1

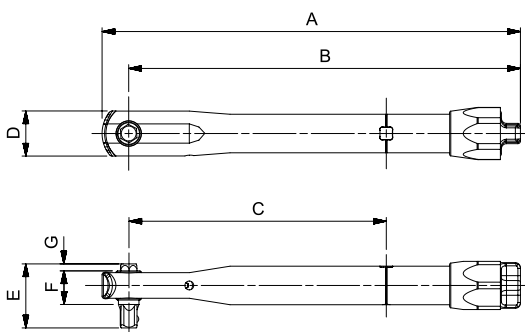

Model 5 'P' Type in storage case



PROFESSIONAL TORQUE WRENCHES



Since its original, award winning launch in 1984, Norbar's Professional torque wrench range has become one of the most popular wrench ranges available worldwide. In this re-engineered version, the core principles of accuracy, durability and comfort are carried over but almost every component part is new and improved.



- Accurate to $\pm 3\%$ of reading which meets the requirements of ISO 6789-2:2017
- Supplied with a traceable 'Calibration Certificate' allowing end users to adhere to more stringent quality control processes

- Large scale for better visibility and more accurate setting
- Fast scale adjustment reducing the effort required to adjust. If you adjust your wrench regularly, you can do more work



Compared with other torque wrenches:

Norbar's 'harmonic drive' scale provides a long scale length for good resolution and accurate setting in both scale units. By contrast, micrometer type scales allow accurate setting in the primary scale unit but relatively poor accuracy of setting in the secondary units because of limited resolution. The Professional wrench is amongst the easiest wrenches on the market to accurately set.

Timestrip® Feature

Torque wrenches should be calibrated once a year as a minimum, more frequently in harsh environments and with high levels of usage. Norbar's Timestrip® gives a visual indication that the wrench is due for re-calibration and has 3, 6, 9 and 12 month graduations. (Timestrip® is a registered trademark of Timestrip UK Ltd).



Unlocked



Locked



Automotive Ratchet



Industrial Ratchet



Timestrip®



Professional Scale



Female Torque Handle



16 mm Spigot End



PROFESSIONAL TORQUE WRENCHES



'Mushroom' Square Drive

2 INDUSTRIAL RATCHET ('Mushroom' Head) - DUAL SCALE

15002*	Pro 50, 3/8", 10 - 50 N·m, 7.5 - 37.5 lbf·ft
15003	Pro 100, 1/2", 20 - 100 N·m, 15 - 75 lbf·ft
15004	Pro 200, 1/2", 40 - 200 N·m, 30 - 150 lbf·ft
15005	Pro 300, 1/2", 60 - 300 N·m, 44 - 222 lbf·ft
15006	Pro 340, 1/2", 60 - 340 N·m, 44 - 250 lbf·ft
15007*	Pro 400, 3/4", 80 - 400 N·m, 60 - 300 lbf·ft

2 INDUSTRIAL RATCHET ('Mushroom' Head) - N·m ONLY

15042*	Pro 50, 3/8", 10 - 50 N·m
15043	Pro 100, 1/2", 20 - 100 N·m
15044	Pro 200, 1/2", 40 - 200 N·m
15045	Pro 300, 1/2", 60 - 300 N·m
15046	Pro 340, 1/2", 60 - 340 N·m
15047*	Pro 400, 3/4", 80 - 400 N·m

2 INDUSTRIAL RATCHET ('Mushroom' Head) - lbf·ft ONLY

15172*	Pro 50, 3/8", 7.5 - 37.5 lbf·ft
15173	Pro 100, 1/2", 15 - 75 lbf·ft
15174	Pro 200, 1/2", 30 - 150 lbf·ft
15175	Pro 300, 1/2", 44 - 220 lbf·ft
15176	Pro 340, 1/2", 44 - 250 lbf·ft
15177*	Pro 400, 3/4", 60 - 300 lbf·ft

2 INDUSTRIAL RATCHET ('Mushroom' Head) - lbf·in ONLY

15052*	Pro 50, 3/8", 90 - 440 lbf·in
15053	Pro 100, 1/2", 200 - 900 lbf·in
15054	Pro 200, 1/2", 400 - 1,800 lbf·in
15055	Pro 300, 1/2", 500 - 2,500 lbf·in
15056	Pro 340, 1/2", 500 - 3,000 lbf·in
15057*	Pro 400, 3/4", 700 - 3,500 lbf·in

* Supplied with 1/2" sq. dr. adaptor

· Supplied with 3/8" sq. dr. adaptor

* Model 400 supplied with a Stepped Square

2 AUTOMOTIVE RATCHET (Reversible) - DUAL SCALE

15008	Pro 15, 1/4", 3 - 15 N·m, 27 - 132 lbf·in
15009	Pro 15, 3/8", 3 - 15 N·m, 27 - 132 lbf·in
15010	Pro 25, 1/4", 5 - 25 N·m, 44 - 220 lbf·in
15011	Pro 25, 3/8", 5 - 25 N·m, 44 - 220 lbf·in
15012	Pro 50, 3/8", 10 - 50 N·m, 7.5 - 37.5 lbf·ft
15013	Pro 50, 1/2", 10 - 50 N·m, 7.5 - 37.5 lbf·ft
15014	Pro 100, 3/8", 20 - 100 N·m, 15 - 75 lbf·ft
15015	Pro 100, 1/2", 20 - 100 N·m, 15 - 75 lbf·ft
15016	Pro 200, 1/2", 40 - 200 N·m, 30 - 150 lbf·ft

2 AUTOMOTIVE RATCHET (Reversible) - N·m ONLY

15018	Pro 15, 1/4", 3 - 15 N·m
15019	Pro 15, 3/8", 3 - 15 N·m
15020	Pro 25, 1/4", 5 - 25 N·m
15021	Pro 25, 3/8", 5 - 25 N·m
15022	Pro 50, 3/8", 10 - 50 N·m
15023	Pro 50, 1/2", 10 - 50 N·m
15024	Pro 100, 3/8", 20 - 100 N·m
15025	Pro 100, 1/2", 20 - 100 N·m
15026	Pro 200, 1/2", 40 - 200 N·m

2 AUTOMOTIVE RATCHET (Reversible) - lbf·ft ONLY

15142	Pro 50, 3/8", 7.5 - 37.5 lbf·ft
15143	Pro 50, 1/2", 7.5 - 37.5 lbf·ft
15144	Pro 100, 3/8", 15 - 75 lbf·ft
15145	Pro 100, 1/2", 15 - 75 lbf·ft
15146	Pro 200, 1/2", 30 - 150 lbf·ft

2 AUTOMOTIVE RATCHET (Reversible) - lbf·in ONLY

15028	Pro 15, 1/4", 27 - 132 lbf·in
15029	Pro 15, 3/8", 27 - 132 lbf·in
15030	Pro 25, 1/4", 44 - 220 lbf·in
15031	Pro 25, 3/8", 44 - 220 lbf·in
15032	Pro 50, 3/8", 90 - 440 lbf·in
15033	Pro 50, 1/2", 90 - 440 lbf·in
15034	Pro 100, 3/8", 200 - 900 lbf·in
15035	Pro 100, 1/2", 200 - 900 lbf·in
15036	Pro 200, 1/2", 400 - 1,800 lbf·in



PROFESSIONAL TORQUE WRENCHES



2 TORQUE HANDLE ADJUSTABLE 16 mm SPIGOT - DUAL SCALE

15060	Pro 15, 16 mm spigot, 3 - 15 N·m, 27 - 132 lbf-in
15061	Pro 25, 16 mm spigot, 5 - 25 N·m, 44 - 220 lbf-in
15062	Pro 50, 16 mm spigot, 10 - 50 N·m, 7.5 - 37.5 lbf-ft
15063	Pro 100, 16 mm spigot, 20 - 100 N·m, 15 - 75 lbf-ft
15064	Pro 200, 16 mm spigot, 40 - 200 N·m, 30 - 150 lbf-ft
15065	Pro 300, 16 mm spigot, 60 - 300 N·m, 44 - 222 lbf-ft

2 TORQUE HANDLE ADJUSTABLE 16 mm SPIGOT - N·m ONLY

15070	Pro 15, 16 mm spigot, 3 - 15 N·m
15071	Pro 25, 16 mm spigot, 5 - 25 N·m
15072	Pro 50, 16 mm spigot, 10 - 50 N·m
15073	Pro 100, 16 mm spigot, 20 - 100 N·m
15074	Pro 200, 16 mm spigot, 40 - 200 N·m
15075	Pro 300, 16 mm spigot, 60 - 300 N·m

2 TORQUE HANDLE ADJUSTABLE 16 mm SPIGOT - lbf-ft ONLY

15082	Pro 50, 16 mm spigot, 7.5 - 37.5 lbf-ft
15083	Pro 100, 16 mm spigot, 15 - 75 lbf-ft
15084	Pro 200, 16 mm spigot, 30 - 150 lbf-ft
15085	Pro 300, 16 mm spigot, 44 - 220 lbf-ft

2 TORQUE HANDLE ADJUSTABLE 16 mm SPIGOT - lbf-in ONLY

15090	Pro 15, 16 mm spigot, 27 - 132 lbf-in
15091	Pro 25, 16 mm spigot, 44 - 220 lbf-in
15092	Pro 50, 16 mm spigot, 90 - 440 lbf-in
15093	Pro 100, 16 mm spigot, 200 - 900 lbf-in
15094	Pro 200, 16 mm spigot, 400 - 1,800 lbf-in
15095	Pro 300, 16 mm spigot, 500 - 2,500 lbf-in



2 FEMALE TORQUE HANDLE ADJUSTABLE - DUAL SCALE

15100	Pro 15, 9 x 12 mm, 3 - 15 N·m, 27 - 132 lbf-in
15101	Pro 25, 9 x 12 mm, 5 - 25 N·m, 44 - 220 lbf-in
15102	Pro 50, 9 x 12 mm, 10 - 50 N·m, 7.5 - 37.5 lbf-ft
15103	Pro 100, 9 x 12 mm, 20 - 100 N·m, 15 - 75 lbf-ft
15104	Pro 200, 9 x 12 mm, 40 - 200 N·m, 30 - 150 lbf-ft
15105	Pro 200, 14 x 18 mm, 40 - 200 N·m, 30 - 150 lbf-ft
15106	Pro 300, 14 x 18 mm, 60 - 300 N·m, 44 - 222 lbf-ft
15107	Pro 340, 14 x 18 mm, 60 - 340 N·m, 44 - 250 lbf-ft
15108	Pro 400, 14 x 18 mm, 80 - 400 N·m, 60 - 300 lbf-ft

2 FEMALE TORQUE HANDLE ADJUSTABLE - N·m ONLY

15110	Pro 15, 9 x 12 mm, 3 - 15 N·m
15111	Pro 25, 9 x 12 mm, 5 - 25 N·m
15112	Pro 50, 9 x 12 mm, 10 - 50 N·m
15113	Pro 100, 9 x 12 mm, 20 - 100 N·m
15114	Pro 200, 9 x 12 mm, 40 - 200 N·m
15115	Pro 200, 14 x 18 mm, 40 - 200 N·m
15116	Pro 300, 14 x 18 mm, 60 - 300 N·m
15117	Pro 340, 14 x 18 mm, 60 - 340 N·m
15118	Pro 400, 14 x 18 mm, 80 - 400 N·m

2 FEMALE TORQUE HANDLE ADJUSTABLE - lbf-ft ONLY

15122	Pro 50, 9 x 12 mm, 7.5 - 37.5 lbf-ft
15123	Pro 100, 9 x 12 mm, 15 - 75 lbf-ft
15124	Pro 200, 9 x 12 mm, 30 - 150 lbf-ft
15125	Pro 200, 14 x 18 mm, 30 - 150 lbf-ft
15126	Pro 300, 14 x 18 mm, 44 - 220 lbf-ft
15127	Pro 340, 14 x 18 mm, 44 - 250 lbf-ft
15128	Pro 400, 14 x 18 mm, 60 - 300 lbf-ft

2 FEMALE TORQUE HANDLE ADJUSTABLE - lbf-in ONLY

15130	Pro 15, 9 x 12 mm, 27 - 132 lbf-in
15131	Pro 25, 9 x 12 mm, 44 - 220 lbf-in
15132	Pro 50, 9 x 12 mm, 90 - 440 lbf-in
15133	Pro 100, 9 x 12 mm, 200 - 900 lbf-in
15134	Pro 200, 9 x 12 mm, 400 - 1,800 lbf-in
15135	Pro 200, 14 x 18 mm, 400 - 1,800 lbf-in
15136	Pro 300, 14 x 18 mm, 500 - 2,500 lbf-in
15137	Pro 340, 14 x 18 mm, 500 - 3,000 lbf-in
15138	Pro 400, 14 x 18 mm, 700 - 3,500 lbf-in



PROFESSIONAL TORQUE WRENCHES



Industrial Ratchet

Model	Pro 50	Pro 100	Pro 200	Pro 300	Pro 340	Pro 400	
Part Number	15002	15003	15004	15005	15006	15007	
	15042	15043	15044	15045	15046	15047	
	15172	15173	15174	15175	15176	15177	
	15052	15053	15054	15055	15056	15057	
Dimensions (mm)	A	335	387	470	593	685	686
	B	317	364	447	567	659	661
	C	231	278	361	480	572	574
	∅D	35	45	45	52	52	51
	E	37	48	48	48	48	47
	F	26	32	32	33	33	24
Weight (kg)	0.7	0.9	1.1	1.4	1.5	1.9	

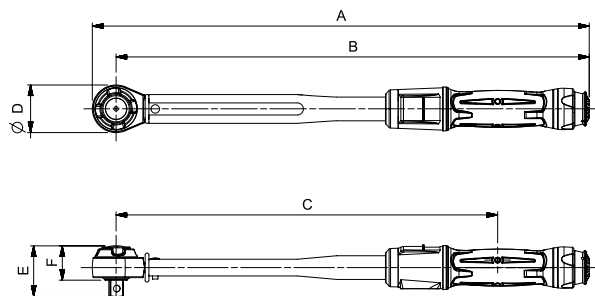

Automotive Ratchet

Model	Pro 15 Pro 25	Pro 50 3/8"	Pro 50 1/2"	Pro 100 3/4"	Pro 100 1/2"	Pro 200	
Part Number	15008, 15009, 15010, 15011, 15018, 15019, 15020, 15021, 15028, 15029, 15030, 15031	15012 15022 15142 15032	15013 15023 15143 15033	15014 15024 15144 15034	15015 15025 15145 15035	15016 15026 15146 15036	
	A	221	327	327	367	367	465
	B	209	312	312	352	352	444
	C	140	226	226	266	266	358
	∅D	25	30	30	30	30	43
	E	25	33	38	33	38	46
F	18	22	22	22	22	30	
Weight (kg)	0.3	0.7	0.7	0.8	0.8	1.0	

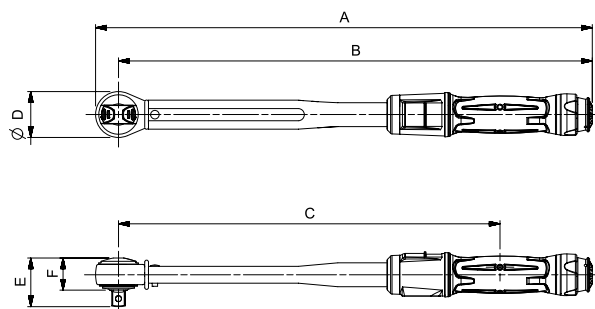

Spigot Torque Handle

Model	Pro 15 Pro 25	Pro 50	Pro 100	Pro 200	Pro 300	
Part Number	15060 15061 15070 15071 15090 15091	15062 15072 15082 15092	15063 15073 15083 15093	15064 15074 15084 15094	15065 15075 15085 15095	
	A	223	322	363	445	569
	B	216	316	356	438	563
	C	148	229	269	351	476
	∅D	16	16	16	16	16
	Weight (kg)	0.3	0.6	0.7	0.9	1.2

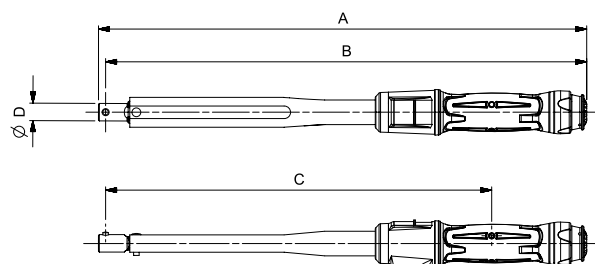

Female Torque Handle

Model	Pro 15 Pro 25	Pro 50	Pro 100	Pro 200 9 x 12 mm	Pro 200 14 x 18 mm	Pro 300	Pro 340	Pro 400	
Part Number	15100 15101 15110 15111 15112 15122 15130 15131	15102 15112 15122 15132	15103 15113 15123 15133	15104 15114 15124 15134	15105 15115 15125 15135	15106 15116 15126 15136	15107 15117 15127 15137	15108 15118 15128 15138	
	A	218	325	365	442	453	570	662	664
	B	204	314	354	431	440	557	649	649
	C	139	227	267	345	353	440	562	563
	D	22	22	22	25	34	34	34	32
	E	20	20	20	20	26	28	28	24
Weight (kg)	0.3	0.6	0.7	0.9	1.0	1.2	1.3	1.7	

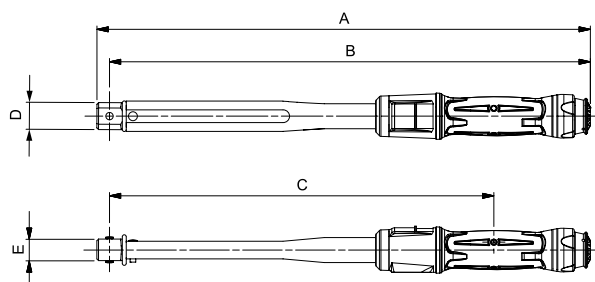



PROFESSIONAL 'P' TYPE TORQUE WRENCHES



For production line applications requiring a sealed torque setting, 'P' Type wrenches have no scale and must be set against a suitable torque measuring device (see pages 90 - 97).

- Accurate to ±3% of reading which meets the requirements of ISO 6789-1:2017
- Colour-coded adjustment seals and locking tool provided
- On request 'P' Type wrenches can be set, marked with the setting and certified for production line applications requiring a sealed torque setting. Only if a pre-set has been requested will the tool be supplied with a Declaration of Conformance



- Push-through ratchet allows clockwise and counter-clockwise torque control

2	PRODUCTION 'P' TYPE - INDUSTRIAL RATCHET (Push-through square)
13051	Pro 60, 3/8", 12 - 60 N·m, 5 - 45 lbf·ft
13052	Pro 60, 1/2", 12 - 60 N·m, 5 - 45 lbf·ft
13053	Pro 100, 3/8", 20 - 100 N·m, 15 - 75 lbf·ft
13054	Pro 100, 1/2", 20 - 100 N·m, 15 - 75 lbf·ft
13055	Pro 200, 1/2", 40 - 200 N·m, 30 - 150 lbf·ft
13057	Pro 300, 1/2", 60 - 300 N·m, 45 - 220 lbf·ft
13056	Pro 400, 3/4", 80 - 400 N·m, 60 - 300 lbf·ft
11698	Calibration Kit Professional 'P' Type
SQ2222	Pre-set, etch and certify (Allow 3 days delivery for this service)



- Reversible, 72 tooth ratchet

2	PRODUCTION 'P' TYPE AUTOMOTIVE RATCHET (Reversible)
11164	Pro 60, 3/8", 12 - 60 N·m, 5 - 45 lbf·ft
11171	Pro 60, 1/2", 12 - 60 N·m, 5 - 45 lbf·ft
11138	Pro 100, 3/8", 20 - 100 N·m, 15 - 75 lbf·ft
11139	Pro 100, 1/2", 20 - 100 N·m, 15 - 75 lbf·ft
11140	Pro 200, 1/2", 40 - 200 N·m, 30 - 150 lbf·ft
SQ2222	Pre-set, etch and certify (Allow 3 days delivery for this service)



Setting a 'P' Type Torque Wrench

2	TORQUE HANDLE PRODUCTION 'P' TYPE 16 mm SPIGOT
11167	Pro 60, 16 mm spigot, 12 - 60 N·m, 5 - 45 lbf·ft
11143	Pro 100, 16 mm spigot, 20 - 100 N·m, 15 - 75 lbf·ft
11144	Pro 200, 16 mm spigot, 40 - 200 N·m, 30 - 150 lbf·ft
11117	Pro 300, 16 mm spigot, 60 - 300 N·m, 45 - 220 lbf·ft
SQ2222	Pre-set, etch and certify (Allow 3 days delivery for this service)



2	FEMALE TORQUE HANDLE PRODUCTION 'P' TYPE
11170	Pro 60, 9 x 12 mm, 12 - 60 N·m, 5 - 45 lbf·ft
11150	Pro 100, 9 x 12 mm, 20 - 100 N·m, 15 - 75 lbf·ft
11151	Pro 200, 9 x 12 mm, 40 - 200 N·m, 30 - 150 lbf·ft
11152	Pro 200, 14 x 18 mm, 40 - 200 N·m, 30 - 150 lbf·ft
11153	Pro 300, 14 x 18 mm, 60 - 300 N·m, 45 - 220 lbf·ft
13068	Pro 400, 14 x 18 mm, 80 - 400 N·m, 60 - 300 lbf·ft
SQ2222	Pre-set, etch and certify (Allow 3 days delivery for this service)



PROFESSIONAL 'P' TYPE TORQUE WRENCHES



Industrial Ratchet

Model	Pro 60, 3/8"	Pro 60, 1/2"	Pro 100, 3/8"	Pro 100, 1/2"	Pro 200	Pro 300	Pro 400
Part Number	13051	13052	13053	13054	13055	13057	13056
Dimensions (mm)	A	295	301	335	342	425	668
	B	277	281	317	321	403	641
	C	212	216	252	256	338	577
	∅D	36	42	36	42	45	54
	E	34	38	34	38	46	46
	F	21	23	21	22	29	29
Weight (kg)	0.6	0.7	0.7	0.7	1.0	1.2	2.0

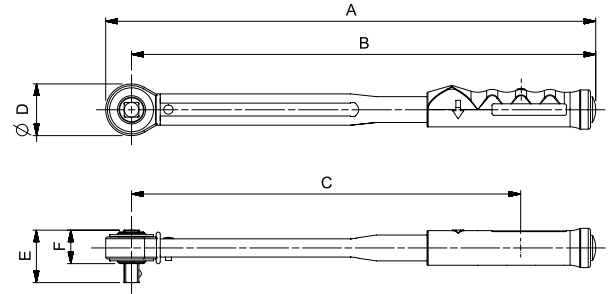

Automotive Ratchet

Model	Pro 60, 3/8"	Pro 60, 1/2"	Pro 100, 3/8"	Pro 100, 1/2"	Pro 200
Part Number	11164	11171	11138	11139	11140
Dimensions (mm)	A	289	289	351	351
	B	274	274	314	314
	C	209	209	249	249
	∅D	30	30	30	30
	E	33	38	33	38
	F	22	22	22	22
Weight (kg)	0.6	0.6	0.7	0.7	1

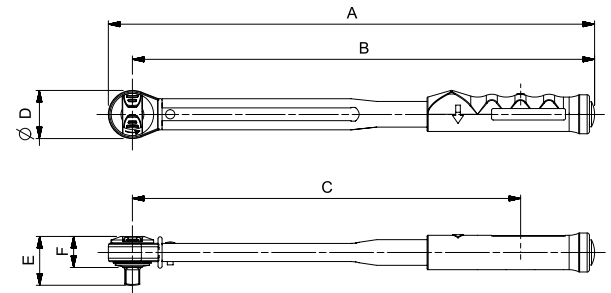

Spigot Torque Handle

Model	Pro 60	Pro 100	Pro 200	Pro 300
Part Number	11167	11143	11144	11117
Dimensions (mm)	A	283	324	405
	B	277	317	399
	C	212	252	334
	∅D	16	16	16
Weight (kg)	0.6	0.6	0.8	1.1

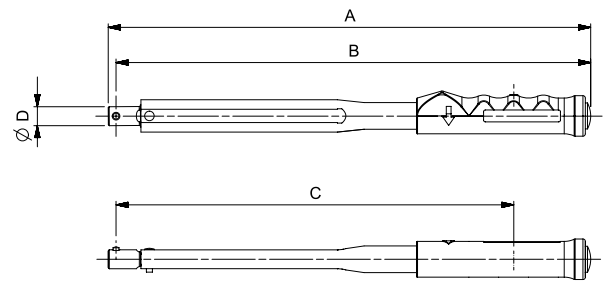

Female Torque Handle

Model	Pro 60 9 x 12 mm	Pro 100 9 x 12 mm	Pro 200, 9 x 12 mm	Pro 200, 14 x 18 mm	Pro 300 14 x 18 mm	Pro 400 14 x 18 mm
Part Number	11170	11150	11151	11152	11153	13068
Dimensions (mm)	A	286	326	403	414	534
	B	274	314	392	400	518
	C	210	250	327	336	453
	D	22	22	25	34	36
	E	20	20	20	26	28
Weight (kg)	0.6	0.6	0.8	0.8	1.1	1.8

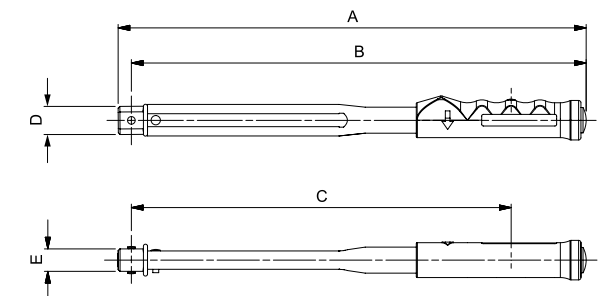



PROFESSIONAL TORQUE WRENCHES NLD SERIES



For precision applications up to 1,500 N·m

- Exceptionally clear torque signal from unique mechanism
- Non-length dependant (NLD) so can be used with or without the supplied extension handle (optional on Pro 650)
- Extension handle significantly reduces operator effort to achieve high torque values
- Accurate to ±3% of reading which meets the requirements of ISO 6789-2:2017
- On request 'P' Type wrenches can be set, marked with the setting and certified for production line applications requiring a sealed torque setting. Only if a pre-set has been requested will the tool be supplied with a Declaration of Conformance



2	ADJUSTABLE RATCHET - DUAL SCALE
14037	Pro 650, 3/4", 130 - 650 N·m, 100 - 480 lbf-ft
14015	Pro 800, 3/4", 200 - 800 N·m, 150 - 600 lbf-ft
14016	Pro 800, 1", 200 - 800 N·m, 150 - 600 lbf-ft
14002	Pro 1000, 3/4", 300 - 1,000 N·m, 220 - 750 lbf-ft
14003	Pro 1000, 1", 300 - 1,000 N·m, 220 - 750 lbf-ft
14004	Pro 1500, 3/4", 500 - 1,500 N·m, 370 - 1,100 lbf-ft
14005	Pro 1500, 1", 500 - 1,500 N·m, 370 - 1,100 lbf-ft

2	ADJUSTABLE RATCHET - N·m ONLY
14038	Pro 650, 3/4", 130 - 650 N·m
14024	Pro 800, 3/4", 200 - 800 N·m
14025	Pro 800, 1", 200 - 800 N·m
14026	Pro 1000, 3/4", 300 - 1,000 N·m
14027	Pro 1000, 1", 300 - 1,000 N·m
14028	Pro 1500, 3/4", 500 - 1,500 N·m
14029	Pro 1500, 1", 500 - 1,500 N·m

2	ADJUSTABLE RATCHET - lbf-ft ONLY
14044	Pro 650, 3/4", 100 - 480 lbf-ft
14045	Pro 800, 3/4", 150 - 600 lbf-ft
14046	Pro 800, 1", 150 - 600 lbf-ft
14047	Pro 1000, 3/4", 220 - 750 lbf-ft
14048	Pro 1000, 1", 220 - 750 lbf-ft
14049	Pro 1500, 3/4", 370 - 1,100 lbf-ft
14050	Pro 1500, 1", 370 - 1,100 lbf-ft

2	TORQUE HANDLE ADJUSTABLE - DUAL SCALE
14040	Pro 650, 22 mm spigot, 130 - 650 N·m, 100 - 480 lbf-ft

2	FEMALE TORQUE HANDLE ADJUSTABLE - DUAL SCALE
14041	Pro 650, 14 x 18 mm, 130 - 650 N·m, 100 - 480 lbf-ft

2	RATCHET PRODUCTION 'P' TYPE (Must be set using a Torque Tester, see pages 90 - 97)
14039	Pro 650, 3/4", 130 - 650 N·m, 100 - 480 lbf-ft
14017	Pro 800, 3/4", 200 - 800 N·m, 150 - 600 lbf-ft
14018	Pro 800, 1", 200 - 800 N·m, 150 - 600 lbf-ft
14007	Pro 1000, 3/4", 300 - 1,000 N·m, 220 - 750 lbf-ft
14008	Pro 1000, 1", 300 - 1,000 N·m, 220 - 750 lbf-ft
14009	Pro 1500, 3/4", 500 - 1,500 N·m, 370 - 1,100 lbf-ft
14010	Pro 1500, 1", 500 - 1,500 N·m, 370 - 1,100 lbf-ft
SQ2222	Pre-set, etch and certify (Allow 3 days delivery for this service)

2	TORQUE HANDLE PRODUCTION 'P' TYPE (Must be set using a Torque Tester, see pages 90 - 97)
14042	Pro 650, 22 mm spigot, 130 - 650 N·m, 100 - 480 lbf-ft
SQ2222	Pre-set, etch and certify (Allow 3 days delivery for this service)

2	FEMALE TORQUE HANDLE PRODUCTION 'P' TYPE (Must be set using a Torque Tester, see pages 90 - 97)
14043	Pro 650, 14 x 18 mm, 130 - 650 N·m, 100 - 480 lbf-ft
SQ2222	Pre-set, etch and certify (Allow 3 days delivery for this service)



8	PRO 650 - 1500 ACCESSORY
14142	Extension Handle (included with Pro 800 - 1500 as standard)



All models supplied in carry case



PROFESSIONAL TORQUE WRENCHES NLD SERIES



Push-Through Ratchet

Model	Pro 650	Pro 800 ¾"	Pro 800 1"	Pro 1000 ¾"	Pro 1000 1"	Pro 1500 ¾"	Pro 1500 1"	Pro 650 'P' Type	Pro 800 ¾" 'P' Type	Pro 800 1" 'P' Type	Pro 1000 ¾" 'P' Type	Pro 1000 1" 'P' Type	Pro 1500 ¾" 'P' Type	Pro 1500 1" 'P' Type	
Part Number	14037 14038 14044	14015 14024 14045	14016 14025 14046	14002 14026 14047	14003 14027 14048	14004 14028 14049	14005 14029 14050	14039	14017	14018	14007	14008	14009	14010	
Dimensions (mm)	A	856	1,037	1,037	1,245	1,245	1,571	1,571	848	1,030	1,030	1,238	1,238	1,563	1,563
	B	823	999	999	1,208	1,208	1,533	1,533	816	992	992	1,201	1,201	1,526	1,526
	C	713	889	889	1,097	1,097	1,423	1,422	713	889	889	1,097	1,097	1,424	1,423
	ØD	66	75	75	75	75	75	75	66	75	75	75	75	75	75
	E	56	58	66	58	66	58	66	55	58	66	58	58	58	66
	F	30	33	33	38	38	38	38	35	38	38	38	38	38	38
Weight (kg)	4.0	5.2	5.2	5.8	5.8	6.7	6.7	4.0	5.2	5.2	5.7	5.7	6.7	6.7	

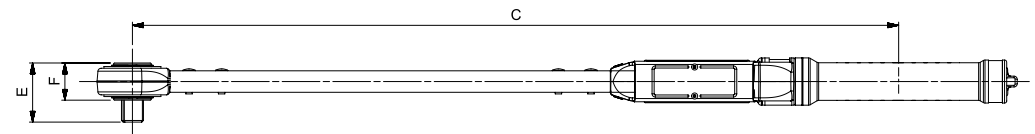
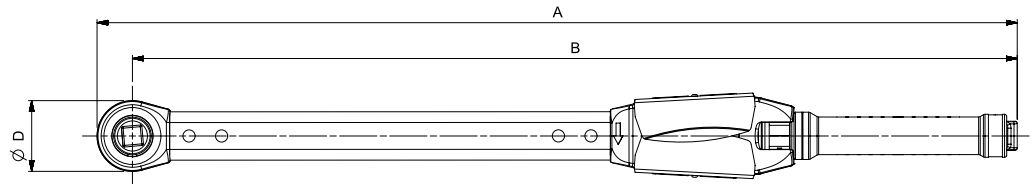

Spigot Torque Handle

Model	Pro 650	Pro 650 'P' Type	
Part Number	14040	14042	
Dimensions (mm)	A	807	800
	B	799	792
	C	688	689
	ØD	22	22
E	45	45	
Weight (kg)	3.6	3.6	

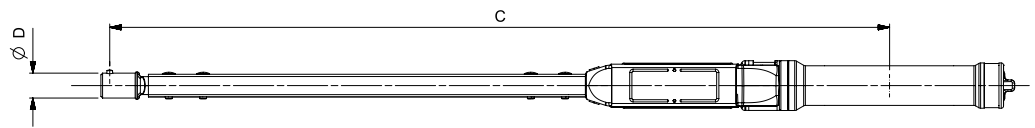
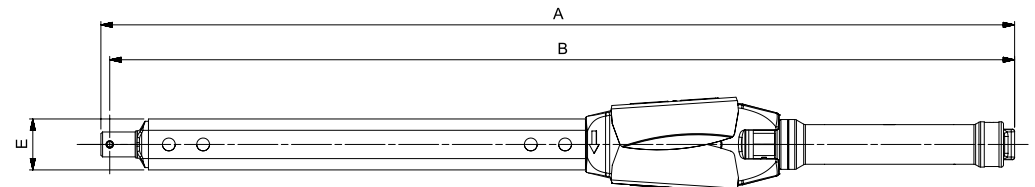

Female Torque Handle

Model	Pro 650	Pro 650 'P' Type	
Part Number	14041	14043	
Dimensions (mm)	A	830	823
	B	815	808
	C	704	705
	D	30	30
	E	45	45
	F	23	23
Weight (kg)	3.6	3.6	

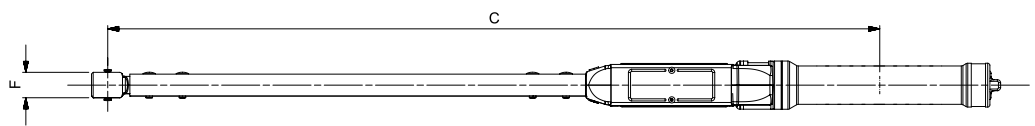
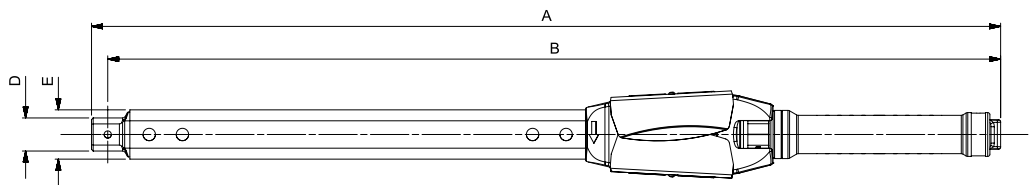

NOTE: When using the Extension Handle (14142) add 495 mm to dimensions 'A' and 'B', add 515 mm to dimension C and add 1.6 kg to the weight.



INDUSTRIAL TORQUE WRENCHES ADJUSTABLE & 'P' TYPE - NEW GENERATION



4AR-N shown split in case

Packed dimensions:

3AR-N to 5R-N
970 x 260 x 95 mm

5AR-N & 6R-N
1,172 x 243 x 91 mm
(L x W x H)



A long-time customer favourite for their unmistakable signal and robustness but now simple to accurately set and split for ease of storage and transportation.

- Unique profiled cam and reaction plate - gives clear torque break point reducing the possibility of over-torquing
- Robust construction gives accurate results to ±4% even in arduous working conditions, meeting the requirements of ISO 6789-1:2017
- Easy to read scale is shielded from dust, dirt and spray
- Easy to set accurately
- Can be split and packed in two parts for a smaller, easier to transport package
- Push-through ratchet allows two direction torquing
- Designed to be cost effectively serviced
- New handle - more comfortable and guides operator's hand to correct position



2	RATCHET ADJUSTABLE - DUAL SCALE
120101	3AR-N, 3/4", 120 - 600 N·m, 100 - 450 lbf·ft
120101.01	3AR-N, 1", 120 - 600 N·m, 100 - 450 lbf·ft
120110	4AR-N, 3/4", 200 - 800 N·m, 150 - 600 lbf·ft
120110.01	4AR-N, 1", 200 - 800 N·m, 150 - 600 lbf·ft
120115	5R-N, 3/4", 300 - 1,000 N·m, 200 - 750 lbf·ft
120115.01	5R-N, 1", 300 - 1,000 N·m, 200 - 750 lbf·ft
120118	5AR-N, 3/4", 700 - 1,500 N·m, 500 - 1,000 lbf·ft
120118.01	5AR-N, 1", 700 - 1,500 N·m, 500 - 1,000 lbf·ft
120120	6R-N, 1", 900 - 2,000 N·m, 700 - 1,500 lbf·ft

2	RATCHET ADJUSTABLE - N·m ONLY
120107	3AR-N, 3/4", 120 - 600 N·m
120107.01	3AR-N, 1", 120 - 600 N·m
120114	4AR-N, 3/4", 200 - 800 N·m
120114.01	4AR-N, 1", 200 - 800 N·m
120117	5R-N, 3/4", 300 - 1,000 N·m
120117.01	5R-N, 1", 300 - 1,000 N·m
120119	5AR-N, 3/4", 700 - 1,500 N·m
120119.01	5AR-N, 1", 700 - 1,500 N·m
120121	6R-N, 1", 900 - 2,000 N·m

2	TORQUE HANDLE ADJUSTABLE - DUAL SCALE
120102	3AR-N, 22 mm Spigot, 120 - 600 N·m, 100 - 450 lbf·ft

2	TORQUE HANDLE ADJUSTABLE - N·m ONLY
120108	3AR-N, 22 mm Spigot, 120 - 600 N·m



2	RATCHET PRODUCTION 'P' TYPE (Must be set using a Torque Tester, see pages 90 - 97)
120104	3AR-N, 3/4", 120 - 600 N·m, 100 - 450 lbf·ft
120104.01	3AR-N, 1", 120 - 600 N·m, 100 - 450 lbf·ft
120111	4AR-N, 3/4", 200 - 800 N·m, 150 - 600 lbf·ft
120111.01	4AR-N, 1", 200 - 800 N·m, 150 - 600 lbf·ft
120116	5R-N, 3/4", 300 - 1,000 N·m, 200 - 750 lbf·ft
120116.01	5R-N, 1", 300 - 1,000 N·m, 200 - 750 lbf·ft
120130	5AR-N, 3/4", 700 - 1,500 N·m, 500 - 1,000 lbf·ft
120130.01	5AR-N, 1", 700 - 1,500 N·m, 500 - 1,000 lbf·ft

2	TORQUE HANDLE PRODUCTION 'P' TYPE (Must be set using a Torque Tester, see pages 90 - 97)
120105	3AR-N, 22 mm Spigot, 120 - 600 N·m, 100 - 450 lbf·ft



INDUSTRIAL TORQUE WRENCHES ADJUSTABLE AND 'P' TYPE - NEW GENERATION



Industrial Push-Through Ratchets

Model	3AR-N	3AR-N 'P' Type	4AR-N	4AR-N 'P' Type	5R-N	5R-N 'P' Type	5AR-N	5AR-N 'P' Type	6R-N	
Part Number	120101 120101.01 120107 120107.01	120104 120104.01	120110 120110.01 120114 120114.01	120111 120111.01	120115 120115.01 120117 120117.01	120116 120116.01	120118 120118.01 120119 120119.01	120130 120130.01	120120 120121	
Dimensions (mm)	A	954	954	1,214	1,214	1,449	1,449	1,764	1,764	1,855
	B	920	920	1,180	1,180	1,415	1,224	1,730	1,730	1,820
	C	829	829	1,089	1,089	1,324	1,324	1,635	1,635	1,773
	ØD	69	69	69	69	69	69	69	69	69
	E	75	75	75	75	75	75	75	75	75
	F	479	479	738	738	974	974	1,379	1,379	1,379
	G	¾" = 55 1" = 63	¾" = 55 1" = 63	¾" = 55 1" = 63	¾" = 55 1" = 63	¾" = 55 1" = 63	¾" = 55 1" = 63	¾" = 55 1" = 63	¾" = 55 1" = 63	63
	H	35	35	35	35	35	35	35	35	35
	J max.	105	18	105	18	105	18	105	18	85
ØK	38	38	38	38	38	38	38	38	38	
Weight (kg)	6.0	6.0	6.7	6.7	7.4	7.4	9.6	9.6	12.75	

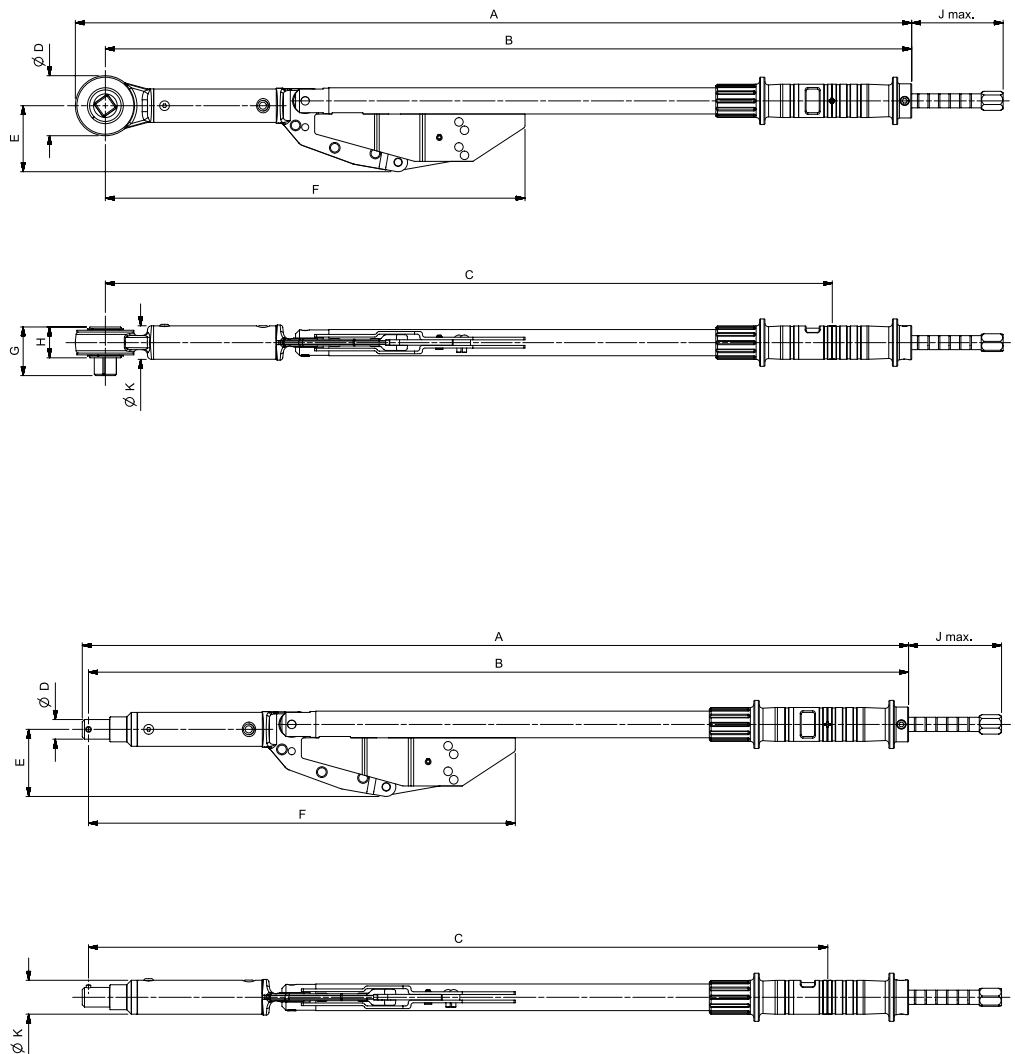

Spigot Torque Handle

Model	3AR-N	3AR-N 'P' Type	
Part Number	120102 120108	120105	
Dimensions (mm)	A	927	927
	B	920	920
	C	829	829
	ØD	22	22
	E	75	75
	F	479	479
	J max.	105	18
ØK	38	38	
Weight (kg)	6.0	5.3	

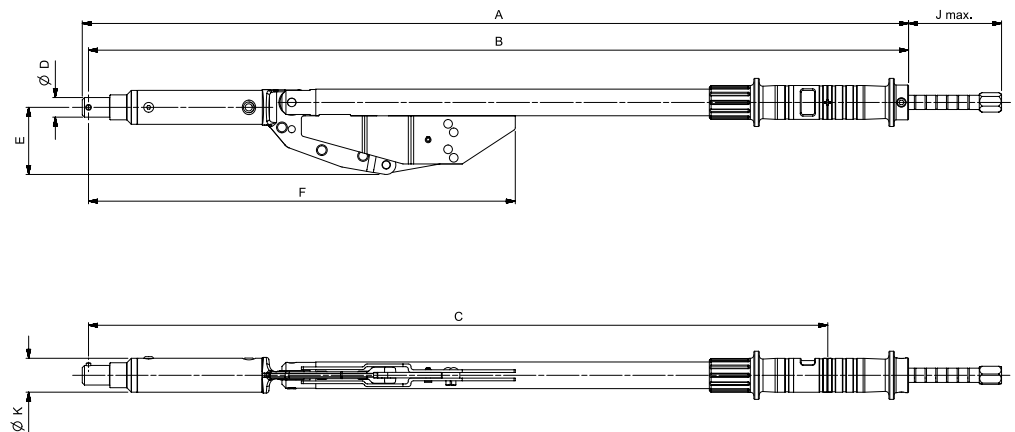

Design Nos. 182086 and 182087 (Canada); Design Nos. 004671063-0001 and 004671063-0002 (EU); Design Nos. D863904 and D871870 (USA)



INDUSTRIAL TORQUE WRENCH - BI-SQUARE



The 1¹/₁₆" Bi-square version of the Industrial Torque Wrench was developed specifically with rail track maintenance in mind. The critical need of the rail industry is to reduce the chance of any object being left on the track. Fitting directly onto rail fishplate bolts means that no socket or square drive is required, two components that could potentially be separated from the regular version of the Industrial Torque Wrench. Other versions of this tool are available on request.

2		BI-SQUARE - DUAL SCALE
12026	1 ¹ / ₁₆ " Bi-Square, 300 - 1,000 N·m, 200 - 750 lbf·ft	

ELECTRODE WRENCHES



For torque tightening of carbon electrodes

Standard torque settings are shown. Other settings are available. The 8" diameter electrode wrench uses the Professional torque handle as the control mechanism. Above 8" the Industrial wrench is used as the control mechanism.

9		LOW RANGE
12506	8" (200 mm)	312 N·m
12530	10" (250 mm)	542 N·m
12531	12" (300 mm)	780 N·m

Other models available on request.

9		HIGH RANGE
12532	14" (350 mm)	1,140 N·m
12533	16" (400 mm)	1,300 N·m
12535	18" (450 mm)	1,500 N·m
12536	20" (500 mm)	2,000 N·m
12537	22" (550 mm)	2,370 N·m
12538	24" (600 mm)	2,370 N·m
12538.HD	24" (600 mm)	3,200 N·m

Model	8" (200 mm)	10" (250 mm)	12" (300 mm)	14" (350 mm)	16" (400 mm)	18" (450 mm)	20" (500 mm)	22" (550 mm)	24" (600 mm)	24" (600 mm)
Part Number	12506	12530	12531	12532	12533	12535	12536	12537	12538	12538.HD
Dimensions (mm)	A	897	1,150	1,286	1,764	1,825	1,727	2,211	2,571	3,350
	B	159	194	239	288	299	336	386	398	446
	C	658	883	994	1,443	1,472	1,643	1,811	2,141	2,885
Weight (kg)	3.2	6.8	8.4	13.8	14.3	16.5	20.0	25.4	26.1	31.7

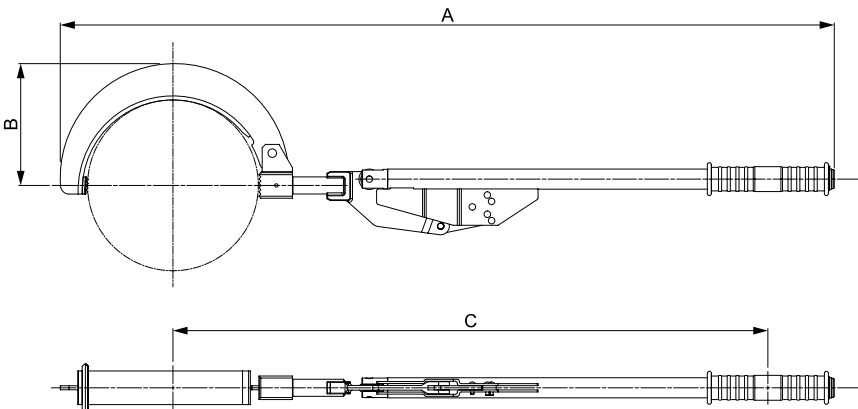



ELECTRONIC SCREWDRIVER AND TORQUE WRENCHES

Norbar Torque Tools offers a range of high-precision electronic torque tools including a screwdriver and an extensive selection of torque wrenches to cover torque values from 0.45 to 800 N.m.

Many of the options in this section have the capability to connect to software that more easily manages data and configures settings. These highly accurate electronic torque and angle tools are the perfect solution for applications that require precision and control.

All Norbar torque wrenches (excluding screwdriver) are offered as standard with a quality ratchet. For applications where interchangeable end fittings are required, 'Torque Handles' which allow for interchangeable spanner fittings, are also available in various models.

ProTronic® Electronic Torque Wrenches	31
ProTronic® Plus Electronic Torque Wrenches	33
ProTronic® Plus Electronic Torque Screwdriver	35
ProTronic® Plus Model 10 and Model 30	36
ProTronic® Plus TorqApp™	37
NorTronic® Electronic Torque Wrenches	39
Spanner End Fittings for 16 mm Torque Handles	41
Spanner End Fittings for 22 mm Torque Handles	42
Spigot Accessories	42
Large Spanner End Fittings for 16 mm Spigot Torque Handles up to 300 N-m	43
Large Spanner End Fittings for 22 mm Spigot Torque Handles up to 650 N-m	44
UKAS Accredited Calibration Certification	45





PROTRONIC® ELECTRONIC TORQUE WRENCHES



New



Large backlit LCD display

The ProTronic® is a high precision electronic torque wrench with a large backlit LCD display, that measures accurate and consistent torque readings. It also features an audible buzzer when pre-set torque/angle value is reached.

- Dual progressive LEDs positioned both sides of the wrench provide an easy visual representation of torque progress allowing the user to more easily anticipate torque target
- Large LCD screen with bright backlight; numbers become larger and bolder during active torque for optimal viewing
- Four alert modes (LCD, progressive LED, audible, vibration) provide excellent feedback in all working conditions
- 5 easily selectable torque units: N·m, lbf·ft, lbf·in, dN·m, kg·cm and kg·m (200 N·m and above)
- The ability to programme up to 10 pre-sets in the tool saves time in setting up frequently occurring applications
- A wide range of advanced features (cycle counter, customisable sleep timer, language selection, auto torque calculation for torque adaptors, calibration alerts, battery level indication, and numerous alert mode customisations) allow the user to tailor the tool to their work preferences
- Torque THEN Angle mode gives the user the ability to conveniently apply an angle to a fastener directly after achieving a torque target without the need to remove the torque wrench from the application
- Settings allow for operation in either English, Spanish, French, German, Italian, Dutch or Portuguese
- Power interruption technology helps to prevent loss of work and continuity if the wrench is impacted
- Patent pending built-in calibration factor feature allows different head lengths to be easily accommodated
- Handle designed for a comfortable and secure grip
- Battery cap has been designed to prevent accidental loosening
- Storage case included
- Supplied with a traceable 'Calibration Certificate' conforming with ISO 6789-2:2017, allowing end users to adhere to more stringent quality control processes

4	PROTRONIC
130517	ProTronic 100, 3/8", 5 - 100 N·m
130518	ProTronic 100, 1/2", 5 - 100 N·m
130519	ProTronic 200, 1/2", 10 - 200 N·m
130520	ProTronic 340, 1/2", 17 - 340 N·m



Dual progressive LEDs positioned both sides of the wrench provide an easy visual representation of torque progress



PROTRONIC® ELECTRONIC TORQUE WRENCHES



Model	ProTronic 100 ½"	ProTronic 100 ¾"	ProTronic 200 ½"	ProTronic 340 ½"	
Part Number	130517	130518	130519	130520	
Dimensions (mm)	A	458	462	650	749
	B	439	439	627	723
	C	344	344	533	629
	ØD	38	46	46	52
	E	34	45	45	45
	F	21	29	29	29
Weight (kg)	1.15	1.30	1.65	1.85	

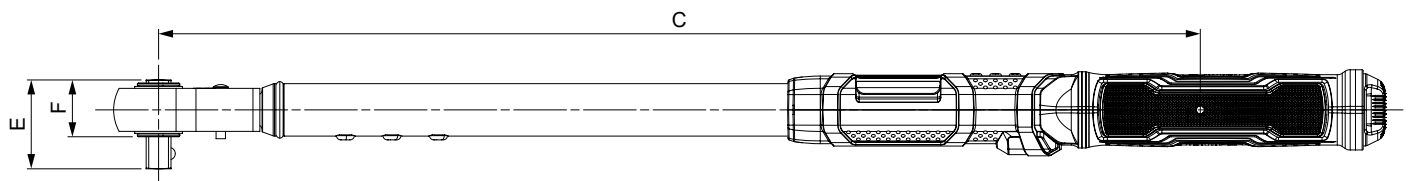
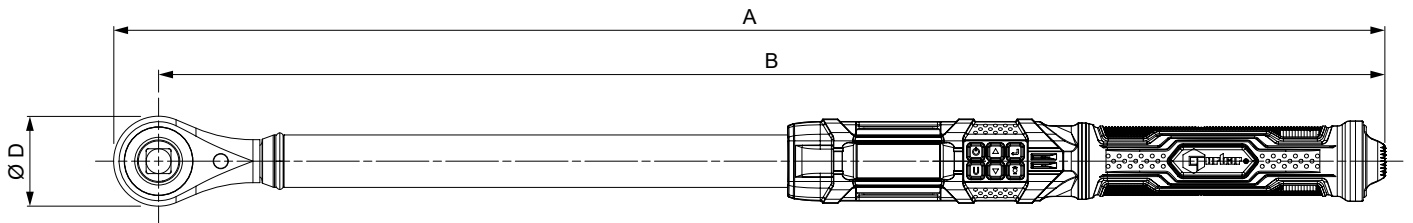

- Accuracy of $\pm 2\%$ when operating between 20% to 100% of tool capacity.
- Angle accuracy of $\pm 1\%$ of reading, $\pm 1^\circ$ @ Angular Velocity $> 10^\circ/\text{Sec} < 180^\circ/\text{Sec}$, $\pm 1^\circ$ for test fixture



PROTRONIC® PLUS ELECTRONIC TORQUE WRENCHES

Calibration details



New



ProTronic® Plus ratchets are detachable on models 100, 200 and 340 allowing for easy customisation from Norbar's huge range of fittings

The ProTronic® Plus retains all the features available in the ProTronic® standard versions and then adds more. Equipped with Bluetooth®, the ProTronic® Plus works alongside a specially created app that allows uploading of wrench configurations and logging of streamed torque and angle readings.

- Patent pending Torque AND angle combo modes allow the user to monitor torque and angle simultaneously
- Works alongside newly developed TorqApp™ designed for live streaming of readings as they are taken
- Dual progressive LEDs have additional settings allowing customisation to user preference
- Up to 50 pre-sets can be programmed into the tool. Preset lock feature allows the tool to be set-up with only these pre-sets available to the operator
- Sequence programming and job modes allows the user to chain together pre-sets in a particular sequence
- UKAS accredited torque calibration in both clockwise and counter-clockwise direction

4	PROTRONIC PLUS
130512	ProTronic Plus 100, 3/8", 5 - 100 N·m
130513	ProTronic Plus 100, 1/2", 5 - 100 N·m
130514	ProTronic Plus 200, 1/2", 10 - 200 N·m
130515	ProTronic Plus 340, 1/2", 17 - 340 N·m
130516	ProTronic Plus 800, 3/4", 40 - 800 N·m



ProTronic® Plus 100 shown with an open end fitting attached (not included)



Dual progressive LEDs positioned both sides of the wrench provide an easy visual representation of torque progress



PROTRONIC® PLUS ELECTRONIC TORQUE WRENCHES



Large backlit LCD display



Model	ProTronic Plus 100 3/8"	ProTronic Plus 100 1/2"	ProTronic Plus 200 1/2"	ProTronic Plus 340 1/2"	ProTronic Plus 800 3/4"	
Part Number	130512	130513	130514	130515	130516	
Dimensions (mm)	A	458	462	650	749	1,264
	B	439	439	627	723	1,233
	C	344	344	533	629	1,138
	ØD	38	46	46	52	63
	E	34	45	45	45	55
	F	21	29	29	29	32
Weight (kg)	1.15	1.30	1.65	1.85	4.95	

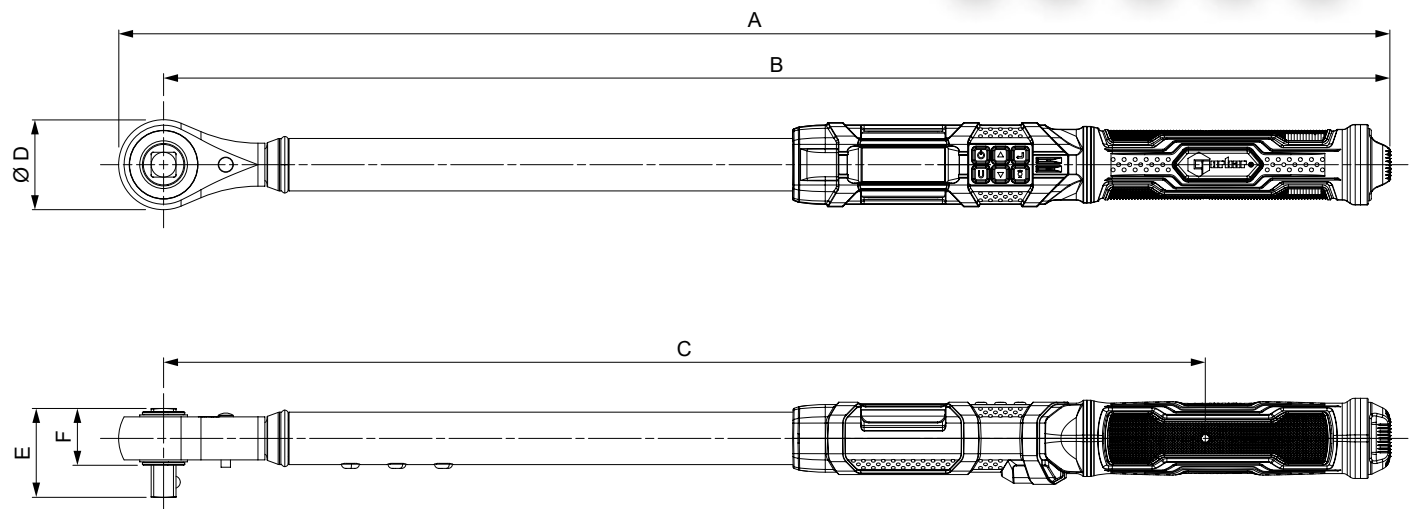

- Accuracy of ±2% when operating between 20% to 100% of tool capacity.
- Accuracy of ±4% when operating between 5% to 19% of tool capacity, except for ProTronic® Plus 9, 10 and 30 where the counter clockwise accuracy between 5% to 19% will be 6%.
- Angle accuracy of ±1% of reading, ±1° @ Angular Velocity >10°/Sec < 180°/Sec, ±1° for test fixture



PROTRONIC® PLUS ELECTRONIC TORQUE SCREWDRIVER

Calibration details



New



The ProTronic® Plus Screwdriver retains all the features of the ProTronic® standard and Plus Wrench in a smaller package with flush fitted buttons to avoid accidental activation during use.

4	PROTRONIC PLUS
130524	ProTronic Plus 9, 1/4" Female Hex, 0.45 - 9 N·m



ProTronic® Plus 9 comes supplied with L shaped handle for easier torque application

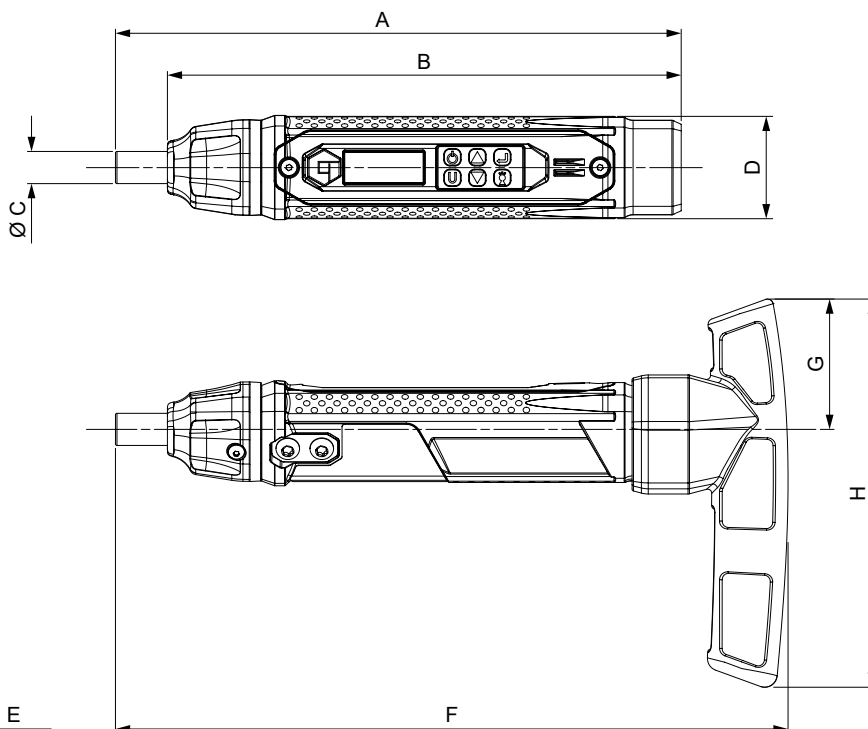

Model	ProTronic Plus 9 1/4"	
Part Number	130524	
Dimensions (mm)	A	190
	B	173
	C	11
	D	35
	E	30
	F	226
	G	44
	H	131
Weight (kg) without Handle	0.21	
Weight (kg) with handle	0.33	



PROTRONIC® PLUS MODEL 10 AND MODEL 30

Calibration details



New



The ProTronic® Plus Model 10 and Model 30 retain all the features of the ProTronic® standard and Plus Wrench in a more compact design allowing for lower torque and access to more space limited applications.

4	PROTRONIC PLUS
130522	ProTronic Plus 10, ¼", 0.5 - 10 N·m
130523	ProTronic Plus 30, ¼", 1.5 - 30 N·m

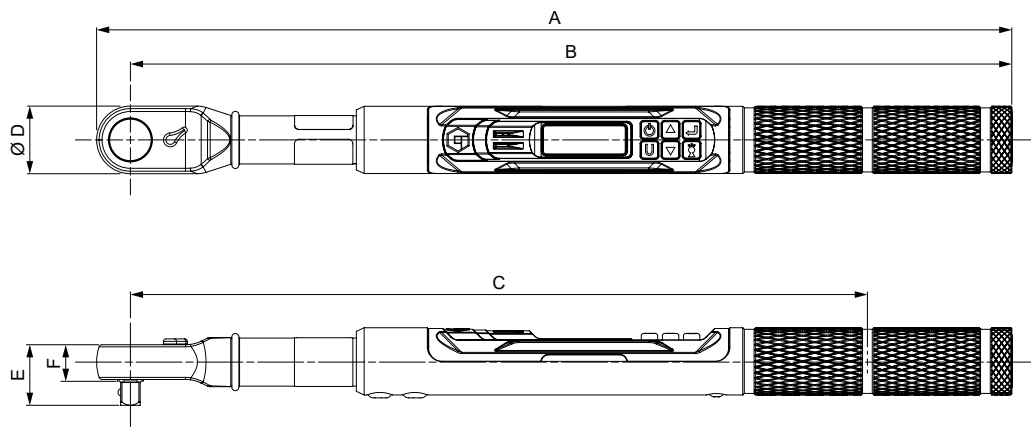

Model	ProTronic Plus 10 ¼"	ProTronic Plus 30 ¼"
Part Number	130522	130523
Dimensions (mm)	A	282
	B	271
	C	234
	ØD	22
	E	20
	F	12
Weight (kg)	0.39	0.42



PROTRONIC® PLUS TORQAPP™

New Android App



TorqApp™ is a free, mobile application that connects to ProTronic® Plus, allowing the user to intuitively change tool settings and download results. Currently available on Android devices with iOS to follow.

- Intuitively change tool settings with ease directly from your Android device
- Instantly receive individually-completed results, with the ability to email these in .csv format quickly
- Monitor application data and progress in real time aiding the operator in keeping a track of bolting progress, particularly useful for sequenced/linked jobs
- Revisiting failed results when in sequence is easy
- Easily view, download or upload application and tool information for past results helping to keep a comprehensive record for traceability purposes



TorqApp™ can connect to any of these products 1 at a time





PROTRONIC® PLUS TORQAPP™



TorqApp™ allows the operator to easily manage tool targets and transmit to a connected tool



TorqApp™ records and verify's application data in real-time



Quickly connecting and disconnecting tools is straightforward and intuitive



TorqApp™ main menu



Sequence programming and job modes easily set up in the app allows the user to chain together pre-sets in a particular sequence



Application and tool information provides a comprehensive record for traceability purposes

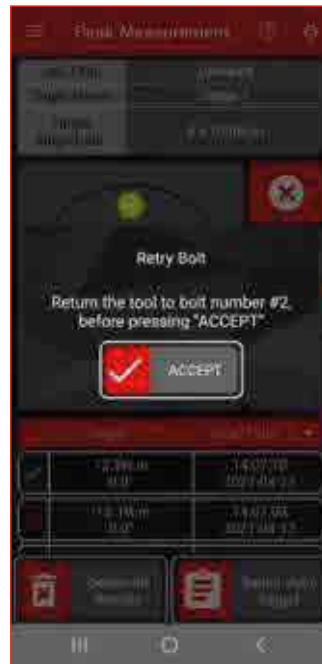

Easily revisit bolting applications that failed at the end of sequences



The ability to email results in csv format



NORTRONIC® ELECTRONIC TORQUE WRENCHES



The NorTronic®, Norbar's electronic torque wrench, sets the benchmark with its unique Torque Data System (TDS) software and combination of accuracy, wireless capability and angle measurement, in a versatile, robust and easy to use package.

- Accurate and traceable torque and angle control
- Two full colour OLED displays positioned at 90° to each other for visual indication both horizontally and vertically
- 3 models covering 5 - 330 N·m
- Extension bars can be made available to increase the operating range of the tool up to 860 N·m, contact Norbar for more information.
- IP44 protection against dust and water ingress
- One piece aluminium handle
- Extruded aluminium case
- Torque & Angle readings can be sent to TDS via the USB lead. For a 868 MHz or 915 MHz wireless connection, a wireless adaptor is required for your PC. Each wireless adaptor can handle up to 8 wrenches. NorTronic® Bluetooth® versions must be connected to TDS via USB lead
- Bluetooth® interface versions with plaintext protocol for easy integration into user environments; set targets, get results, and stream live torque and angle data using your own software and equipment on phones, computers and tablets
- Ability to interface to ProSuite® process control software
- Calibration date of tool can be displayed via TDS or third party software
- ASCII mode allows for interfacing the tool to third party software
- When used with a HandTorque® gearbox the NorTronic® can directly display, save and send the output Torque of the HandTorque®
- Ability to set a Torque, Angle and Final Torque Target
- Ability to produce and save Torque & Angle graphs (in real time) from a USB connected tool
- Ability to have up to 15 linked or non-linked targets on the tool at any one time
- Angle calibration in accordance with VDI/VDE 2648
- UKAS accredited torque calibration in both clockwise and counter-clockwise direction



Compatible with Norbar's huge range of spanner end fittings

Unique Torque Data System software enables data management and archiving to a PC



NorTronic® DLL (Dynamic Link Library) plugin enables NorTronic® 868 MHz and 915 MHz version tools to be interfaced to a customer's existing production line control software. DLL is not compatible with Bluetooth® versions.

Contact Norbar for more details.



NORTRONIC® ELECTRONIC TORQUE WRENCHES

Calibration details



4	NORTRONIC 868 MHZ
43500	NorTronic 50, 3/8", 868 MHz, 5 - 50 N·m
43501	NorTronic 50, 1/2", 868 MHz, 5 - 50 N·m
43502	NorTronic 200, 1/2", 868 MHz, 20 - 200 N·m
43503	NorTronic 330, 1/2", 868 MHz, 33 - 330 N·m
43508	USB Wireless Adaptor, 868 MHz

For UK, Europe, Singapore and India



4	NORTRONIC 915 MHZ
43504	NorTronic 50, 3/8", 915 MHz, 5 - 50 N·m
43505	NorTronic 50, 1/2", 915 MHz, 5 - 50 N·m
43506	NorTronic 200, 1/2", 915 MHz, 20 - 200 N·m
43507	NorTronic 330, 1/2", 915 MHz, 33 - 330 N·m
43509	USB Wireless Adaptor, 915 MHz

For USA, Canada, Australia and New Zealand



4	NORTRONIC BLUETOOTH®
43534	NorTronic 50, 3/8", Bluetooth®, 5 - 50 N·m
43535	NorTronic 50, 1/2", Bluetooth®, 5 - 50 N·m
43536	NorTronic 200, 1/2", Bluetooth®, 20 - 200 N·m
43537	NorTronic 330, 1/2", Bluetooth®, 33 - 330 N·m
43513	USB Wireless Adaptor, Bluetooth®

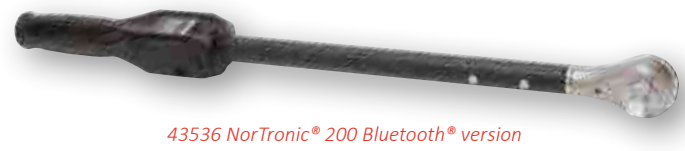

Model	NorTronic 50 3/8"	NorTronic 50 1/2"	NorTronic 200 1/2"	NorTronic 330 1/2"
Part Number	43500 43504 43534	43501 43505 43535	43502 43506 43536	43503 43507 43537
Dimensions (mm)	A	468	472	592
	B	449	449	569
	C	388	388	508
	ØD	38	46	46
	E	34	45	45
	F	21	29	29
Weight (kg)	1.2	1.2	1.5	1.9

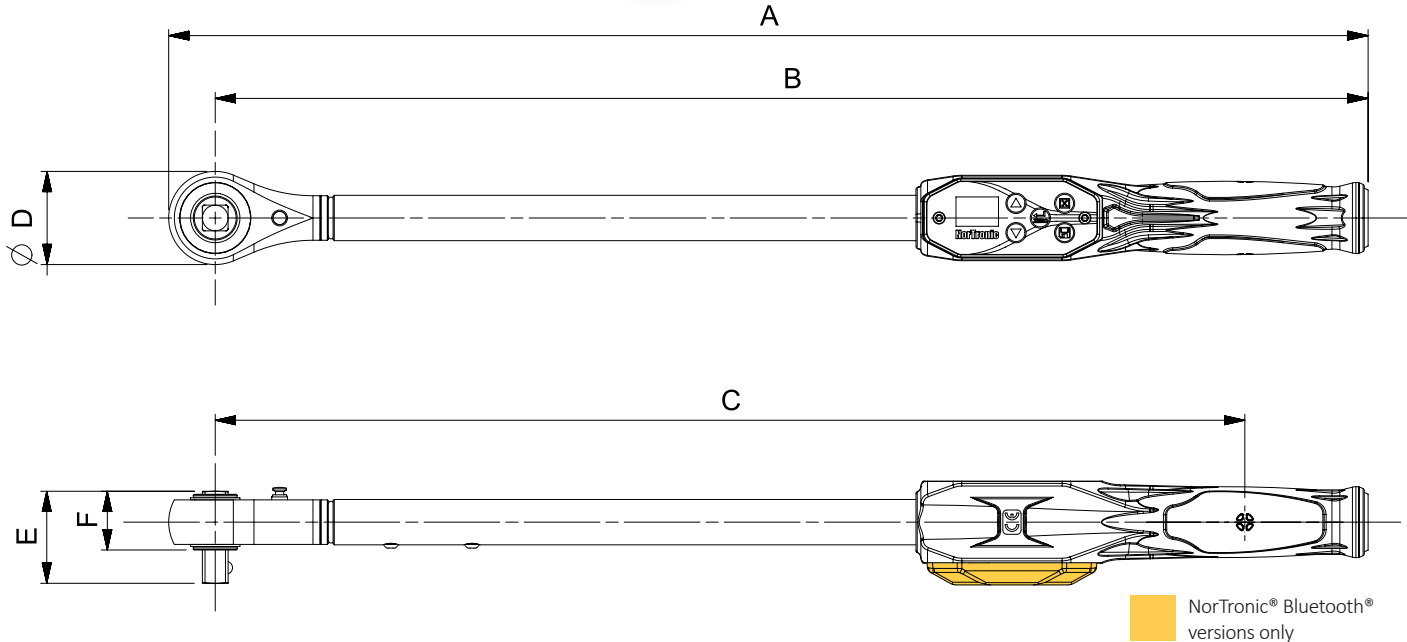



SPANNER END FITTINGS FOR 16 mm TORQUE HANDLES

See below for explanation of part numbers. Other sizes available on request – including bespoke ETO solutions.

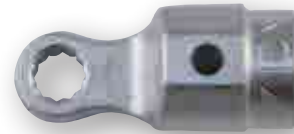
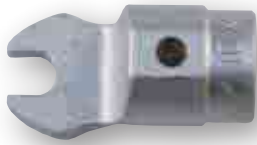

2	OPEN ENDS METRIC	2	OPEN ENDS IMPERIAL
29841	7 mm, 9 N·m*	29701	¼", 7 N·m*
29842	8 mm, 13 N·m*	29702	⅜", 13 N·m*
29843	9 mm, 19 N·m*	29703	½", 21 N·m*
29844	10 mm, 25 N·m*	29704	⅞", 32 N·m*
29845	11 mm, 32 N·m*	29705	1", 48 N·m*
29846	12 mm, 41 N·m*	29706	⅞", 67 N·m*
29847	13 mm, 51 N·m*	29707	⅞", 90 N·m*
29848	14 mm, 63 N·m*	29708	1 ¼", 118 N·m*
29849	15 mm, 77 N·m*	29709	¾", 150 N·m*
29850	16 mm, 92 N·m*	29710	13/16", 187 N·m*
29851	17 mm, 107 N·m*	29711	7/8", 230 N·m*
29876	18 mm, 128 N·m*	29712	15/16", 281 N·m*
29877	19 mm, 149 N·m*	29713	1", 330 N·m*
29852	20 mm, 172 N·m*	29714	1 1/16", 330 N·m*
29853	21 mm, 198 N·m*	29715	1 1/8", 330 N·m*
29854	22 mm, 225 N·m*	29716	1 3/16", 330 N·m*
29855	23 mm, 255 N·m*	29717	1 ¼", 330 N·m*
29856	24 mm, 287 N·m*	29718	1 5/16", 330 N·m*
29857	25 mm, 322 N·m*		
29858	26 mm, 330 N·m*		
29878	27 mm, 330 N·m*		
29860	29 mm, 330 N·m*		
29861	30 mm, 330 N·m*		
29863	32 mm, 330 N·m*		
297100	36 mm, 330 N·m*		

2	RING ENDS METRIC	2	RING ENDS IMPERIAL
29881	7 mm, 25 N·m*	29726	¼", 25 N·m*
29882	8 mm, 35 N·m*	29727	⅜", 35 N·m*
29883	9 mm, 45 N·m*	29728	½", 42 N·m*
29884	10 mm, 52 N·m*	29729	⅞", 73 N·m*
29885	11 mm, 73 N·m*	29730	1", 115 N·m*
29886	12 mm, 89 N·m*	29731	⅞", 170 N·m*
29887	13 mm, 107 N·m*	29732	⅞", 226 N·m*
29888	14 mm, 128 N·m*	29733	1 1/16", 260 N·m*
29889	15 mm, 150 N·m*	29734	¾", 305 N·m*
29890	16 mm, 175 N·m*	29735	13/16", 330 N·m*
29891	17 mm, 201 N·m*	29736	7/8", 330 N·m*
29913	18 mm, 230 N·m*	29737	15/16", 330 N·m*
29914	19 mm, 261 N·m*	29738	1", 330 N·m*
29892	20 mm, 294 N·m*	29739	1 1/16", 330 N·m*
29893	21 mm, 330 N·m*		
29894	22 mm, 330 N·m*		
29895	23 mm, 330 N·m*		
29896	24 mm, 330 N·m*		
29915	27 mm, 330 N·m*		



2	FLARE ENDS METRIC
29921	7 mm, 7 N·m*
29922	8 mm, 6 N·m*
29923	9 mm, 5 N·m*
29924	10 mm, 26 N·m*
29926	12 mm, 13 N·m*
29927	13 mm, 34 N·m*
29928	14 mm, 24 N·m*
29929	15 mm, 18 N·m*
29930	16 mm, 66 N·m*
29931	17 mm, 56 N·m*
29953	18 mm, 45 N·m*
29954	19 mm, 80 N·m*
29932	20 mm, 60 N·m*
29933	21 mm, 43 N·m*
29934	22 mm, 172 N·m*
29935	23 mm, 153 N·m*
29936	24 mm, 118 N·m*
29955	27 mm, 76 N·m*

* Max torque values listed are proof torques quoted in BS 192:1982 & BS 3555:1988 (tested on hardened hexagon test stud).



SPANNER END FITTINGS FOR 22 mm TORQUE HANDLES

See below for explanation of part numbers. Other sizes available on request – including bespoke ETO solutions.



2	OPEN ENDS METRIC
29963.22	22 mm Open End, Max 225 N·m
29963.24	24 mm Open End, Max 287 N·m
29963.30	30 mm Open End, Max 536 N·m
29963.32	32 mm Open End, Max 550 N·m
29963.36	36 mm Open End, Max 550 N·m
29963.41	41 mm Open End, Max 550 N·m
29963.46	46 mm Open End, Max 550 N·m



2	RING ENDS METRIC
29960.22	22 mm Ring End, Max 367 N·m
29960.24	24 mm Ring End, Max 450 N·m
29960.27	27 mm Ring End, Max 550 N·m
29960.30	30 mm Ring End, Max 550 N·m
29960.32	32 mm Ring End, Max 550 N·m
29960.36	36 mm Ring End, Max 550 N·m
29960.41	41 mm Ring End, Max 550 N·m
29960.46	46 mm Ring End, Max 550 N·m



SPIGOT ACCESSORIES



2	16 mm SPIGOT ACCESSORIES
44509	3/8" Ratchet with Push-through square
29825	1/2" Ratchet with Push-through square
44510	1/2" Ratchet with Push-through square for NorTronic
29828	3/8" Fixed Square Drive
29827	1/2" Fixed Square Drive
29829	3/8" Reversible Ratchet Head
29830	1/2" Reversible Ratchet Head
29832	Blank End Fitting
85242	Blank End Fitting for Open End
11343	Blank End Fitting for Ring End
72000	Spigot Adaptor 16 mm female to 22 mm male



2	22 mm SPIGOT ACCESSORIES
29969	3/4" Square Drive Fixed Head
29972	3/4" Ratchet with Push-through square
85719	Blank End Fitting for Open End
85720	Blank End Fitting for Ring End





LARGE SPANNER END FITTINGS FOR 16 mm SPIGOT TORQUE HANDLES UP TO 300 N·m

See below for explanation of part numbers. Other sizes available on request – including bespoke ETO solutions.



2 OPEN OFFSET
METRIC 16 mm

29218.OO.Mxx | 30 - 80 mm

2 OPEN OFFSET
IMPERIAL 16 mm

29218.OO.lxx | 1 3/16" - 3 1/4"

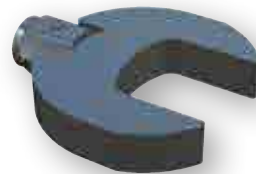

2 OPEN INLINE
METRIC 16 mm

29218.OI.Mxx | 30 - 80 mm

2 OPEN INLINE
IMPERIAL 16 mm

29218.OI.lxx | 1 3/16" - 3 1/4"



2 RING OFFSET
METRIC 16 mm

29218.RO.Mxx | 30 - 80 mm

2 RING OFFSET
IMPERIAL 16 mm

29218.RO.lxx | 1 3/16" - 3 1/4"

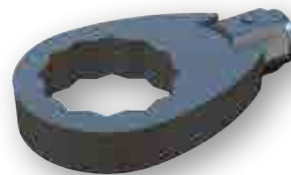

2 RING INLINE
METRIC 16 mm

29218.RI.Mxx | 30 - 80 mm

2 RING INLINE
IMPERIAL 16 mm

29218.RI.lxx | 1 3/16" - 3 1/4"



2 FLARE OFFSET
METRIC 16 mm

29218.FO.Mxx | 11 - 80 mm

2 FLARE OFFSET
IMPERIAL 16 mm

29218.FO.lxx | 1 3/16" - 3 1/4"

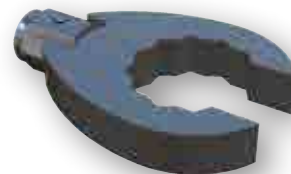

2 FLARE INLINE
METRIC 16 mm

29218.FI.Mxx | 30 - 80 mm

2 FLARE INLINE
IMPERIAL 16 mm

29218.FI.lxx | 1 3/16" - 3 1/4"

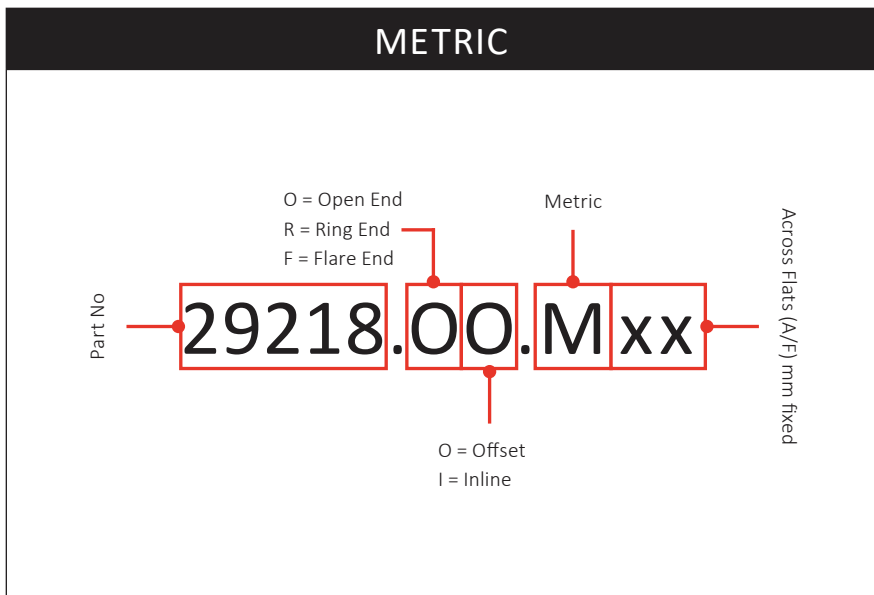



LARGE SPANNER END FITTINGS FOR 22 mm SPIGOT TORQUE HANDLES UP TO 650 N·m

See below for explanation of part numbers. Other sizes available on request – including bespoke ETO solutions.



2 OPEN OFFSET
METRIC 22 mm

29219.OO.Mxx | 30 - 80 mm

2 OPEN OFFSET
IMPERIAL 22 mm

29219.OO.lxx | 1 3/16" - 3 1/4"

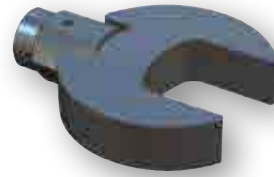

2 OPEN INLINE
METRIC 22 mm

29219.OI.Mxx | 30 - 80 mm

2 OPEN INLINE
IMPERIAL 22 mm

29219.OI.lxx | 1 3/16" - 3 1/4"



2 RING OFFSET
METRIC 22 mm

29219.RO.Mxx | 30 - 80 mm

2 RING OFFSET
IMPERIAL 22 mm

29219.RO.lxx | 1 3/16" - 3 1/4"

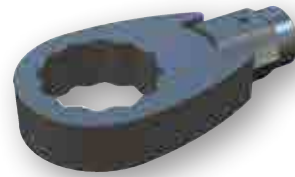

2 RING INLINE
METRIC 22 mm

29219.RI.Mxx | 30 - 80 mm

2 RING INLINE
IMPERIAL 22 mm

29219.RI.lxx | 1 3/16" - 3 1/4"

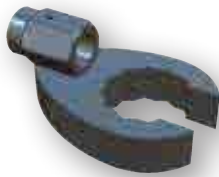

2 FLARE OFFSET
METRIC 22 mm

29219.FO.Mxx | 30 - 80 mm

2 FLARE OFFSET
IMPERIAL 22 mm

29219.FO.lxx | 1 3/16" - 3 1/4"

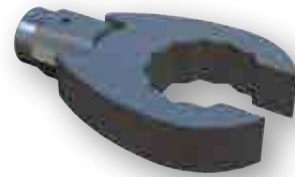

2 FLARE INLINE
METRIC 22 mm

29219.FI.Mxx | 30 - 80 mm

2 FLARE INLINE
IMPERIAL 22 mm

29219.FI.lxx | 1 3/16" - 3 1/4"

IMPERIAL

Part No

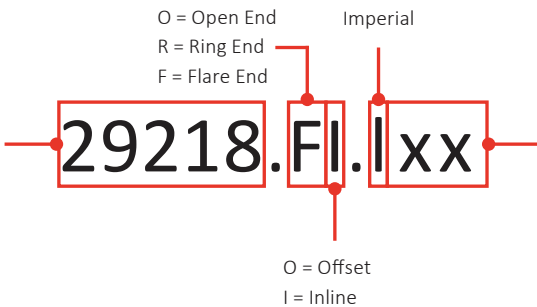

(Please use the table on the right)*
Imperial code

IMPERIAL A/F	CODE	IMPERIAL A/F	CODE	IMPERIAL A/F	CODE
1 3/16"	19	1 15/16"	31	2 11/16"	43
1 1/4"	20	2"	32	2 3/4"	44
1 5/16"	21	2 1/16"	33	2 13/16"	45
1 3/8"	22	2 1/8"	34	2 7/8"	46
1 7/16"	23	2 3/16"	35	2 15/16"	47
1 1/2"	24	2 1/4"	36	3"	48
1 9/16"	25	2 5/16"	37	3 1/16"	49
1 5/8"	26	2 3/8"	38	3 3/8"	50
1 11/16"	27	2 7/16"	39	3 3/16"	51
1 3/4"	28	2 1/2"	40	3 3/4"	52
1 13/16"	29	2 9/16"	41		
1 7/8"	30	2 5/8"	42		

*Example: 1 7/8" open inline for 22 mm Spigot = 29219.OI.I30



UKAS ACCREDITED CALIBRATION CERTIFICATION



Accredited Calibration Laboratory No. 0256

The hallmark of Norbar's high standard of workmanship is clearly seen in the fact that we were the first torque equipment manufacturer to have an in-house UKAS accredited calibration laboratory. We have no intention of resting on our laurels and take pride that we still provide the most comprehensive service available, ensuring we evolve to continue to meet your needs.

Norbar's laboratory has approval for torques between 0.005 and 108,500 N·m and operates to BS EN ISO/IEC 17025:2017, which sets standards for the technical competence of the laboratory. This should not be confused with laboratories claiming ISO 9001 which relates only to a laboratory's quality management systems.

The part numbers shown below are for a comprehensive calibration, for all new torque screwdrivers and torque wrenches, including NorTronic®, up to the maximum capacity shown.

Please see page 141 for Norbar's After Sales Service.

12	ONE DIRECTION
TWCC4.CW	Up to 400 N·m / 300 lbf·ft
TWCC5.CW	Up to 1,000 N·m / 750 lbf·ft
TWCC6.CW	Up to 3,000 N·m / 2,200 lbf·ft

12	TWO DIRECTIONS
TWCC4.CW+CCW	Up to 400 N·m / 300 lbf·ft
TWCC5.CW+CCW	Up to 1,000 N·m / 750 lbf·ft
TWCC6.CW+CCW	Up to 3,000 N·m / 2,200 lbf·ft





HANDTORQUE® TORQUE MULTIPLIERS

Torque wrench design offers just two solutions to the challenge of applying higher torques: either the load at the handle must be higher or the lever length must be greater. Clearly there are practical and safety limits to both of these solutions. Often there will not be the space to operate a torque wrench of sufficient length to comfortably apply such high torques and the chance that the wrench might slip off the nut increases as length increases.

Norbar's solution is to use a compact, epicyclic gearbox called a HandTorque® multiplier to accurately multiply the input torque provided by a torque wrench by a fixed ratio. This fixed ratio might be in the order of 5:1, 27:1 or even up to 135:1 for very high torque application. This means that a much smaller torque wrench can be used for a given torque application and the combined weight of the torque multiplier and torque wrench will often be lower than for a single large torque wrench. For example, one could apply 1,000 N·m using a Norbar Model 1000 torque wrench weighing 5.8 kg or an HT-52/22.2 combined with a NorTorque® 60 with a total weight of just under 2 kg and a lever length of just 310 mm.

The Norbar HandTorque® multiplier range is the most comprehensive available. Standard products are available up to 47,500 N·m (35,000 lbf·ft) and 'specials' to 300,000 N·m (220,000 lbf·ft). A range of 'nose extensions' for reaching difficult to access bolts and a full range of torque transducers for highly accurate torque monitoring are available.

HandTorque® Torque Multipliers	47
Anti Wind-Up Ratchets (AWUR)	49
HandTorque® HT3-1000	50
HandTorque® HT3 Series	50
HandTorque® HT4 Series	51
HandTorque® Compact Series	52
HandTorque® Compact Series Kits	53
HandTorque® Standard Series	53
HandTorque® Small Diameter Series	55
UKAS Accredited Calibration Certification	55





HANDTORQUE® TORQUE MULTIPLIERS

What is a Torque Multiplier?

A torque multiplier is a device that increases the torque that can be applied by an operator. This is because the power output cannot exceed the power input, the number of output revolutions will be lower than the number of input revolutions (Torque x rpm = Power).

How HandTorque® Torque Multipliers Work

HandTorque® multipliers incorporate an 'epicyclic' or 'planetary' gear train having one or more stages. Each stage of gearing increases the torque applied, allowing Norbar to offer multipliers typically in ratios of 5:1, 27:1 and 135:1.

In the planetary gear system, torque is applied to the input gear or 'sun' gear. Three or four planet gears whose teeth are engaged with the 'sun' gear therefore rotate. The outside casing of the multiplier, or 'annulus' is also engaged with the planet gear teeth, and would normally rotate in the opposite direction to the 'sun' gear. A reaction arm prevents the annulus from rotating, and this causes the planet gears to orbit around the 'sun'. The planet gears are held in a 'planetary' carrier which also holds the output square drive, therefore as the planet gears orbit around the sun gear, the carrier and so the square drive turns. Without the reaction arm to keep the annulus stationary, the output square will not apply torque.

No gearbox is 100% efficient, and so the velocity ratio (the number of turns that the input has to make to achieve one revolution of the output) is not the same as the torque multiplication ratio. Norbar multipliers are engineered such that each gear stage typically has a nominal 5:1 ratio, this means a velocity ratio of typically 5.45:1 which results in a true torque multiplication factor of 5.2:1.



Without a torque multiplier



With a torque multiplier

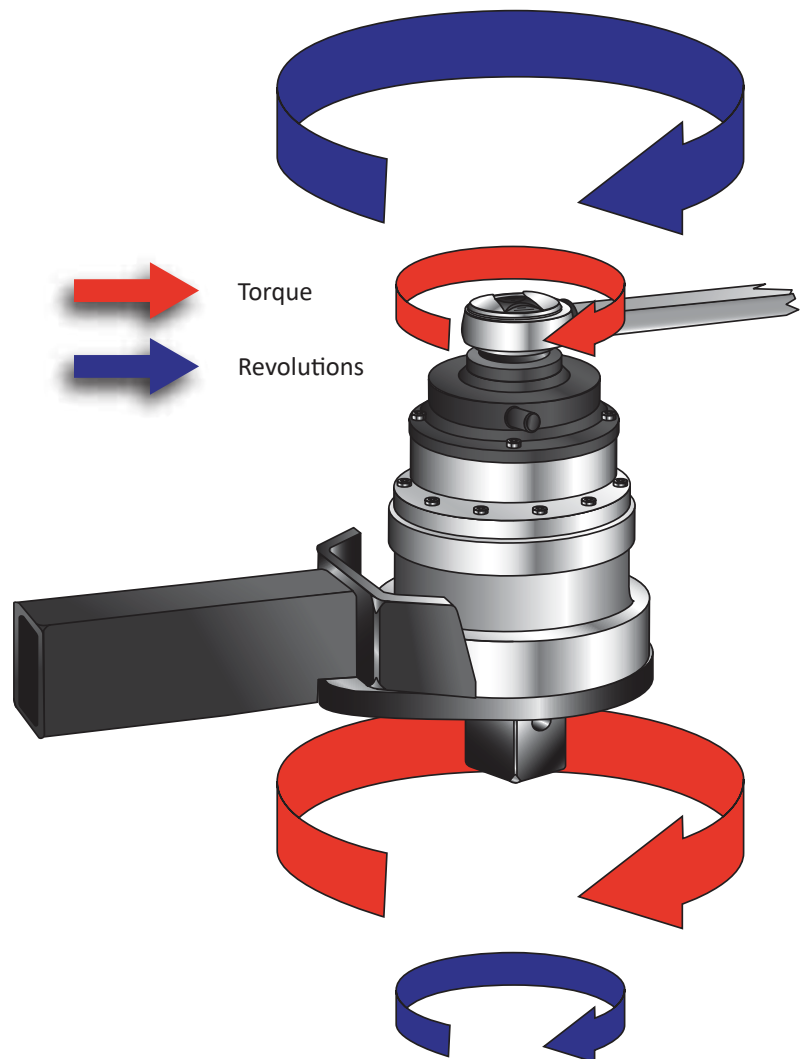



HANDTORQUE® TORQUE MULTIPLIERS

Why use a HandTorque® Multiplier?

- **Safety** – use of long levers can be dangerous. Torque multipliers allow for a reduction in the lever length or operator effort
- **Space limitation** – the use of a long lever may be impossible due to the available space
- **Accuracy** – torque will be applied most accurately when it is applied smoothly and slowly. Torque multipliers enable this by removing much of the physical effort from the tightening task



Advantages of the Norbar HandTorque® System

Norbar gearboxes are built to an extremely high standard of precision. All gears rotate on needle roller bearings about hardened and ground journal pins. As a result, Norbar HandTorques can be relied upon to have a mean torque multiplication accuracy of $\pm 4\%$, taking the uncertainty out of high torque tightening.

Summary of Norbar torque multiplier advantages:

- The ratio stated is the mean torque multiplication factor
- No correction charts are needed to determine torque output
- Strong, safe Anti Wind-Up Ratchet available on most models for safe and comfortable operation
- A wide range of alternative reaction styles are available making the HandTorque® adaptable to many applications
- Electronic torque transducers are available on most models for precise torque control
- Compact Series are supplied with their own unique calibration certificate allowing the accurate calculation of input torque for critical applications

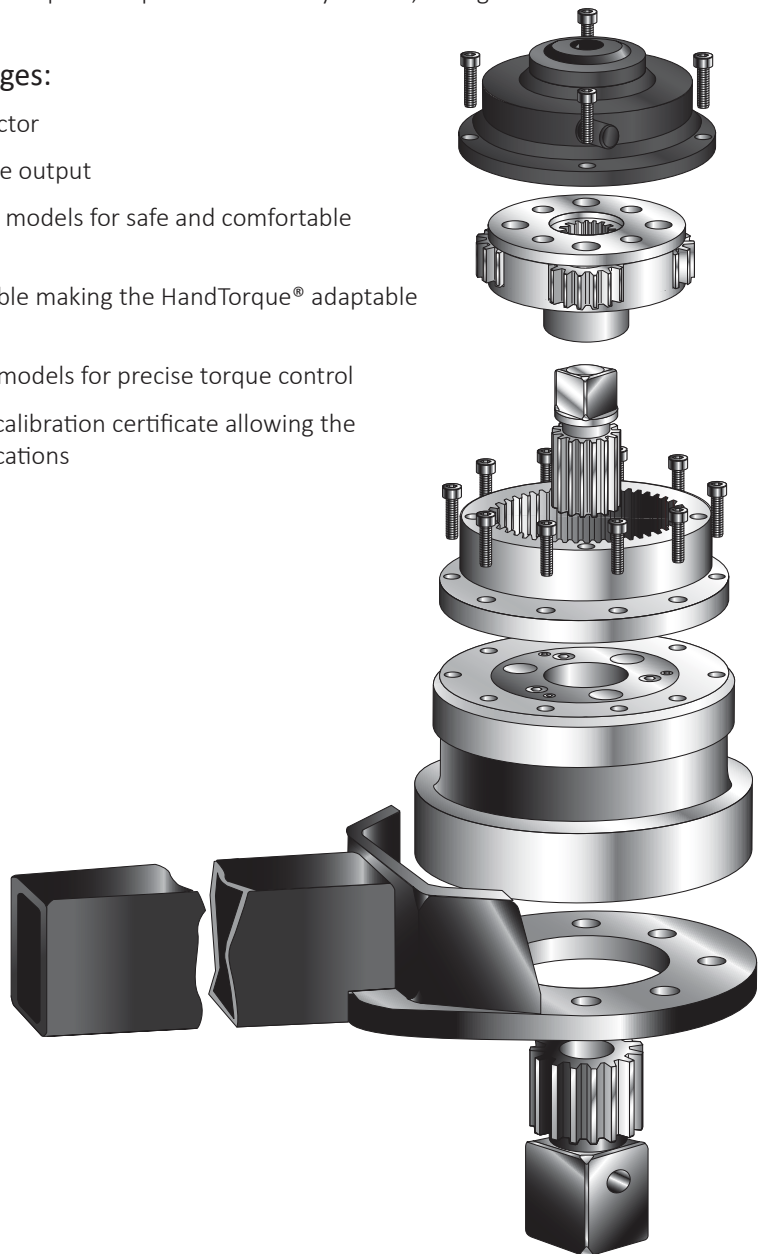



ANTI WIND-UP RATCHETS (AWUR)



Norbar Anti Wind-Up Ratchets (AWUR)

Most multipliers with ratios of 15:1 and over are fitted with an Anti Wind-Up Ratchet. The multiplier can be thought of as a spring which must be fully wound before any tightening/untightening work can be applied to the bolt.

The AWUR ensures that the 'spring' stays wound and that any further torque input to the multiplier is applied directly to the bolt.

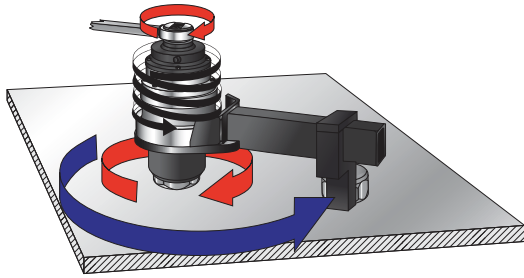

Multiplier behaves like a very stiff 'spring'

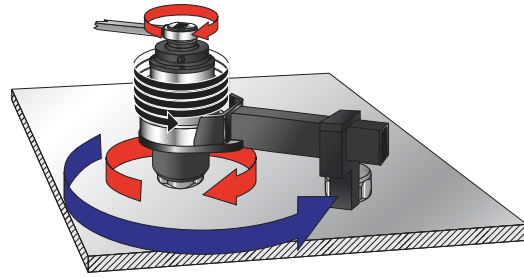

Multiplier will achieve maximum torque only after the 'spring' has been taken up



AWUR benefits include:

1. The torque input device cannot fly backwards against the direction of operation if it is suddenly released.
2. Without an Anti Wind-Up Ratchet, it will often be necessary to continue to make 360° sweeps with the torque input device otherwise the multiplier will 'unwind'. However, obstructions will often make this impossible (as demonstrated in this example).

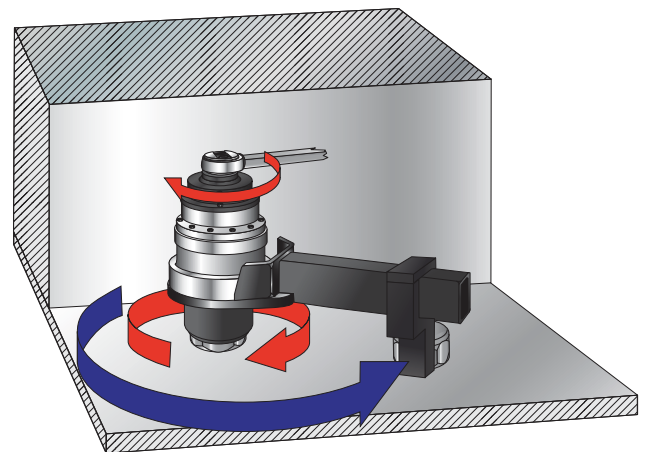

AWUR set to counter-clockwise operation



AWUR set to neutral



AWUR set to clockwise operation



HANDTORQUE® HT3-1000



- 5:1 nominal torque multiplication, reaction dependant. Mean ratio with cranked foot is 4.8:1; with straight reaction is 4.9:1
- ±4% mean torque multiplication accuracy
- Small and compact design
- Updated aesthetics with tough silver metallic powder coat
- Supplied with 2 reaction bar styles for maximum versatility
- Quick-change cranked reaction with improved flexibility allowing reaction in 8 orientations
- Robust construction means minimal maintenance and long life
- If calibration is required, a UKAS accredited calibration certificate may be ordered (at extra cost)

2	HT3-1000
180260	HT3-1000, 1,000 N·m Kit, ½" input x ¾" output

HANDTORQUE® HT3 SERIES



- 5:1 mean torque multiplication, accuracy ±4%
- Supplied with two reaction bar styles for maximum versatility
- Robust construction means minimal maintenance and long life
- Supplied in a carry case, the Highwayman is ideal for inclusion in the heavy vehicle tool kit
- 1,300 N·m version has a spare ¾" output square included in the kit
- Multiplier head only (no reaction bars or plastic box) also available
- 1,300 N·m version, part no. 17218
- 2,700 N·m version, part no. 17219
- If calibration is required, a UKAS accredited calibration certificate may be ordered (at extra cost)

2	HT3 SERIES
17220	HT3 1,300 N·m Kit, ½" input x ¾" output
17221	HT3 2,700 N·m Kit, ¾" input x 1" output

Kits are supplied in a carry case with a reaction bar and a reaction foot (17220 also contains a spare ¾" sq. dr.)

Model	HT3-1000	HT3 1,300 N·m	HT3 2,700 N·m
Part Number	180260	17220	17221
Mean Multiplication Ratio	Nominal	5:1	5:1
	With Cranked Reaction	4.8:1	4.75:1
	With Straight Reaction	4.9:1	5:1
Dimensions (mm)	ØD	65	108
	H1	63	103
	H2	21	44
	L	273	398
	R1	55	77
	R2 min.	83	140
	R2 max.	143	212
	R3 max.	240	344
Tool Weight (kg)	1.5	3.8	3.8
Reaction Weight (kg)	Cranked	0.5	1.36
	Straight	0.7	1.1

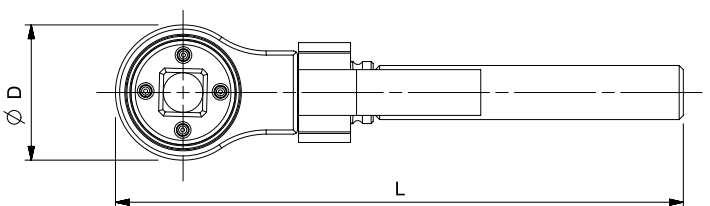
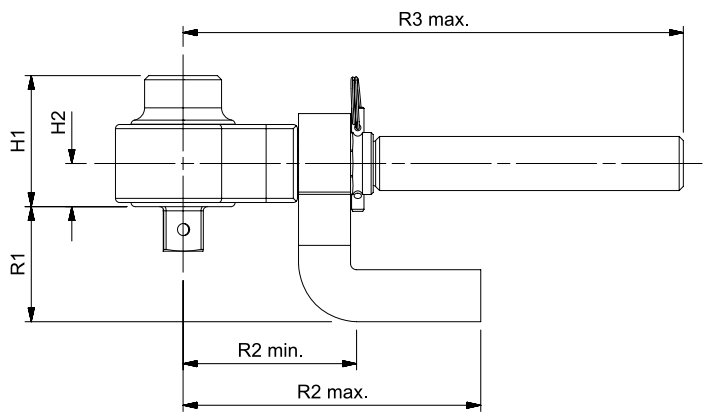

HT3 1300/2700 on right shown in comparison with HT3 1000





HANDTORQUE® HT4 SERIES



- Robust construction means minimal maintenance and long life
- Mean 15.5:1 (3,000 N·m) or 26:1 (4,500 N·m) torque multiplication, accuracy ±4%
- High ratios allow the use of a small torque wrench
- Supplied in carrying case with replacement square drive
- Anti Wind-Up Ratchet fitted to allow safer and more practical operation
- Angle protractor for easy torque and angle tightening
- If calibration is required, a UKAS accredited calibration certificate may be ordered (at extra cost)



4	HT4 SERIES
17022	HT4 AWUR, 3,000 N·m, ½" in 1" out
17021	HT4 AWUR, 4,500 N·m, ½" in 1" out



Model	HT4/15.5 AWUR	HT4/26 AWUR	
Part Number	17022	17021	
Mean Multiplication Ratio	15.5:1	26:1	
Dimensions (mm)	ØD	108	108
	H1	131	149
	H2	55	55
	L	498	498
	R max.	444	444
Tool Weight (kg)	6.1	7.0	
Reaction Weight (kg)	1.9	1.9	

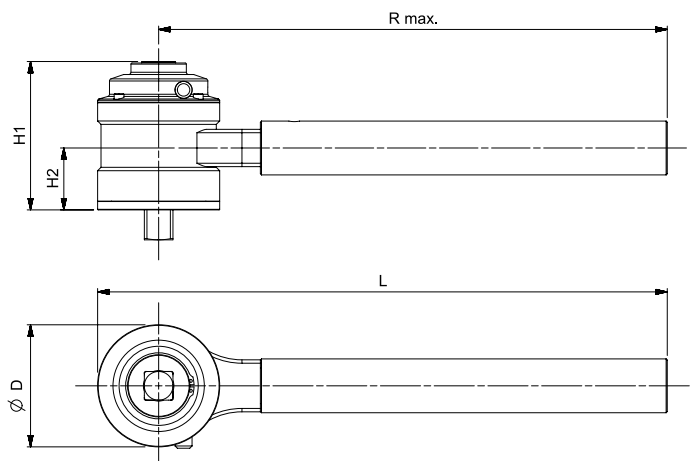



HANDTORQUE® COMPACT SERIES



HT-72/27 (181450)



- Compact dimensions allow excellent access to applications and easy, safe handling
- Lightweight for torque capacity
- Supplied as standard with a steel reaction arm. Other options are available on request, including customised reactions
- Mean torque multiplication accuracy $\pm 4\%$
- Robust, 48 tooth Anti Wind-Up Ratchet (AWUR) contains the forces generated during tightening for safe and easy operation
- Each multiplier is supplied with its own unique traceable calibration certificate allowing the accurate calculation of input torque for critical applications
- If you order a UKAS accredited calibration certificate (available at extra cost), this certificate will be provided in place of the traceable calibration certificate.



4	COMPACT SERIES
181440	HT-52/4.7, 1,000 N·m, ½" in ¾" out
181441	HT-52/22.2, 1,000 N·m, ⅜" in ¾" out
181442	HT-52/22.2, 1,000 N·m, ½" in ¾" out
181443	HT-52/22.2 AWUR, 1,000 N·m, ⅜" in ¾" out
181444	HT-52/22.2 AWUR, 1,000 N·m, ½" in ¾" out
181445	HT-52/22.2 AWUR, 1,000 N·m, ⅜" in 1" out
181446	HT-52/22.2 AWUR, 1,000 N·m, ½" in 1" out
181447	HT-72/5.2, 1,500 N·m, ½" in 1" out
181448	HT-72/5.2, 1,000 N·m, ¾" in ¾" out
181449	HT-72/5.2, 2,000 N·m, ¾" in 1" out
181450	HT-72/27, 2,000 N·m, ½" in 1" out
181451	HT-72/27 AWUR, 2,000 N·m, ½" in 1" out
181452	HT-92/25 AWUR, 4,000 N·m, ½" in 1" out
181453	HT-119/25.5 AWUR, 7,000 N·m, ½" in 1½" out

Model	HT-52/4.7	HT-52/22.2	HT-52/22.2 AWUR	HT-72/5.2	HT-72/5.2	HT-72/5.2	HT-72/27	HT-72/27 AWUR	HT-92/25 AWUR	HT-119/25.5 AWUR
Part Number	181440	181441 181442	181443 181444 181445 181446	181447	181448	181449	181450	181451	181452	181453
Mean Multiplication Ratio	4.7:1	22.2:1	22.2:1	5.2:1	5.2:1	5.2:1	27:1	27:1	25:1	25.5:1
Dimensions (mm)	ØD max.	52	52	72	72	72	72	72	92	119
	H	91	116	130	117	122	117	132	150	212
	R1	58	58	58	74	69	74	74	69	91
	R2 min.	71	71	71	112	112	112	112	112	152
	R2 max.	131	131	131	165	165	165	165	175	212
Tool Weight (kg)	1.0	1.3	1.4	2.5	2.5	2.6	2.9	3.2	5.4	9.3
Reaction Weight (kg)	0.9	0.9	0.9	1.4	1.4	1.4	1.4	1.4	2.5	4.0

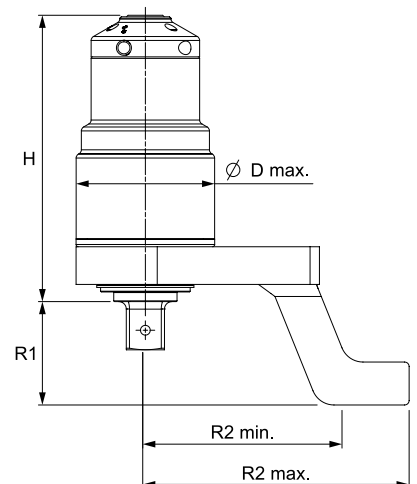



HANDTORQUE® COMPACT SERIES KITS



SpinNor (1/2") included
Part No. 19253

Multiplier & Torque Wrench Kits

For convenience, it is now possible to purchase a torque multiplier from the 'Compact Series' packaged with the appropriate torque wrench, up to 4,000 N·m. This allows the operator to arrive at the bolting application with everything needed in one robust carry case. Space has also been allowed in the carry case for accessories such as sockets.

The torque multiplier is supplied with its own unique calibration certificate and the torque wrench is supplied with a Declaration of Conformance, allowing accurate calculation of input torque to the multiplier for critical applications.

- All kits include a 'SpinNor' which aids fast reaction location
- All models include an Anti Wind-up Ratchet on the multiplier

4	HT COMPACT SERIES & TORQUE WRENCH KITS
18186	HT-52, 1,000 N·m, 3/4" out + NorTorque 60 1/2" Dual Scale
18192	HT-72, 2,000 N·m, 1" out + NorTorque 100 1/2" Dual Scale
18195	HT-92, 4,000 N·m, 1" out + NorTorque 200 1/2" Dual Scale

HANDTORQUE® STANDARD SERIES



HT 5/25

- Mean torque multiplication accuracy ±4%
- High ratios allow the use of a small torque wrench, multipliers can be used where access is limited
- Anti Wind-Up Ratchet available on high ratio models
- Other reaction styles can be designed to suit specific applications
- Electronic torque transducers can be fitted for precise torque monitoring, see page 105
- Other models available up to 300,000 N·m
- If calibration is required, a UKAS accredited calibration certificate may be ordered (at extra cost) up to 6,000 N·m

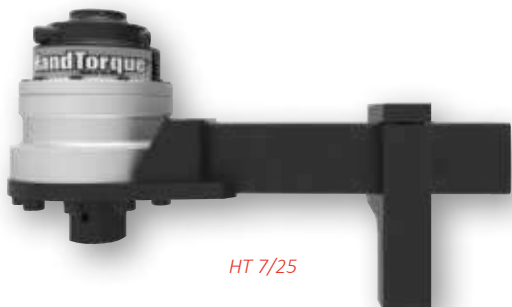

HT 7/25

4	STANDARD SERIES
16010	HT 1/5, 1,700 N·m, 1/2" in 3/4" out
16012.HD	HT 2/5, 1,700 N·m, 3/4" in 1" out
16034.HD	HT 2/25, 1,700 N·m, 1/2" in 1" out
16089.HD	HT 2/25 AWUR, 1,700 N·m, 1/2" in 1" out
16014	HT 5/5, 3,400 N·m, 3/4" in 1" out
16028	HT 5/25, 3,400 N·m, 1/2" in 1" out
16090	HT 5/25 AWUR, 3,400 N·m, 1/2" in 1" out
16016	HT 6/5, 3,400 N·m, 3/4" in 1 1/2" out
16024	HT 6/25, 3,400 N·m, 1/2" in 1 1/2" out
16092	HT 6/25 AWUR, 3,400 N·m, 1/2" in 1 1/2" out
16093	HT 6/125 AWUR, 3,400 N·m, 1/2" in 1 1/2" out
16067	HT 7/5, 6,000 N·m, 3/4" in 1 1/2" out
16018	HT 7/25, 6,000 N·m, 1/2" in 1 1/2" out
16065	HT 7/25 AWUR, 6,000 N·m, 1/2" in 1 1/2" out
16068	HT 7/125 AWUR, 6,000 N·m, 1/2" in 1 1/2" out
16059	HT 9/25, 9,500 N·m, 3/4" in 1 1/2" out
16070	HT 9/25 AWUR, 9,500 N·m, 3/4" in 1 1/2" out
16071	HT 9/125 AWUR, 9,500 N·m, 1/2" in 1 1/2" out
16082	HT 11/25, 20,000 N·m, 3/4" in 2 1/2" out
16049	HT 11/125 AWUR, 20,000 N·m, 1/2" in 2 1/2" out
16053	HT 13/125 AWUR, 47,500 N·m, 1/2" in 2 1/2" out

Other gear ratios may be available upon request.

If AWUR is not required please enquire for part number.

HT 13/125 fitted with weld prepared reaction ring as standard.

AWUR = Anti Wind-Up Ratchet. See page 49

NOTE: Model name does not reflect multiplication ratios, see mean multiplication ratios on page 54

For spares kits for Norbar multipliers, please see page 144.



HANDTORQUE® STANDARD SERIES



Model	HT 1/5	HT 2/5	HT 2/25	HT 2/25 AWUR	HT 5/5	HT 5/25	HT 5/25 AWUR	HT 6/5	HT 6/25	HT 6/25 AWUR	HT 6/125 AWUR
Part Number	16010	16012.HD	16034.HD	16089.HD	16014	16028	16090	16016	16024	16092	16093
Mean Multiplication Ratio	5.2:1	5.2:1	27:1	27:1	5.2:1	27:1	27:1	5.2:1	27:1	27:1	135:1
Dimensions (mm)	∅D	108	108	108	108	119	119	119	119	119	119
	H	83	98	98	114	106	127	106	128	134	159
	L	303	303	303	303	355	355	355	355	355	355
	R1	N/A	N/A	N/A	N/A	N/A	N/A	N/A	N/A	N/A	N/A
	R2 min.	83	83	83	83	86	86	86	86	86	86
	R2 max.	216	216	216	216	263	263	263	263	263	263
Tool Weight (kg)	3.0	3.2	4.6	6.7	4.7	6.4	7.5	4.7	6.4	7.5	9.0
Reaction Weight (kg)	2.2	2.2	2.2	2.2	2.5	2.5	2.5	2.5	2.5	2.5	2.5

Model	HT 7/5	HT 7/25	HT 7/25 AWUR	HT 7/125 AWUR	HT 9/25	HT 9/25 AWUR	HT 9/125 AWUR	HT 11/25	HT 11/125 AWUR	HT 13/125 AWUR	
Part Number	16067	16018	16065	16068	16059	16070	16071	16082	16049	16053	
Mean Multiplication Ratio	5.2:1	27:1	27:1	135:1	27:1	27:1	135:1	27:1	135:1	135:1	
Dimensions (mm)	∅D	144	144	144	184	184	184	212	212	315	
	H	136	157	162	188	166	162	182	208	322	
	L	423	423	423	423	448	448	448	609	609	341
	R1	84	84	84	84	84	84	84	N/A	N/A	N/A
	R2 min.	150	150	150	150	175	175	175	320	320	N/A
	R2 max.	331	331	331	331	351	351	351	500	500	N/A
Tool Weight (kg)	8.1	9.6	10.7	12.2	16.3	17.4	18.9	31.7	32.1	95.2	
Reaction Weight (kg)	6.3	6.3	6.3	6.3	8.3	8.3	8.3	13.3	13.3	6.9	

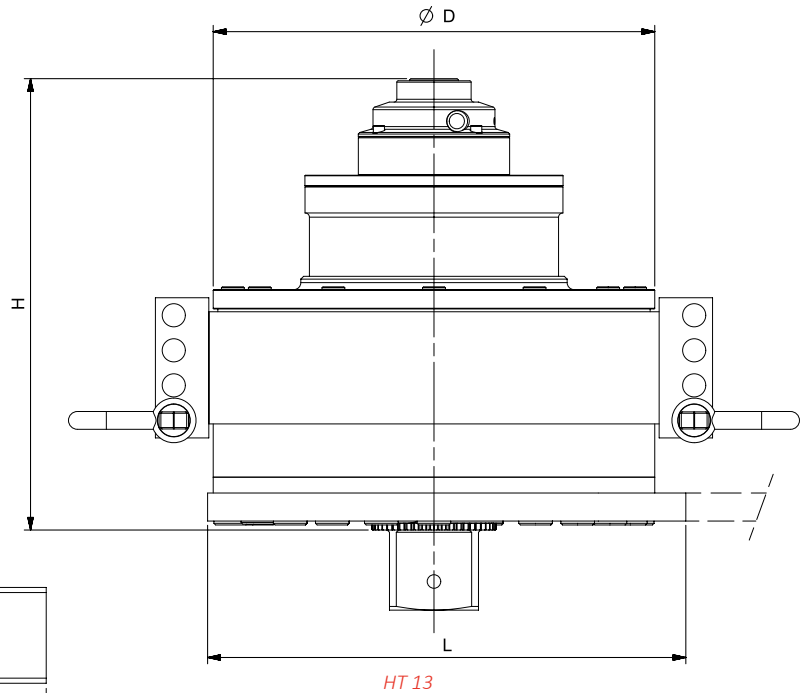
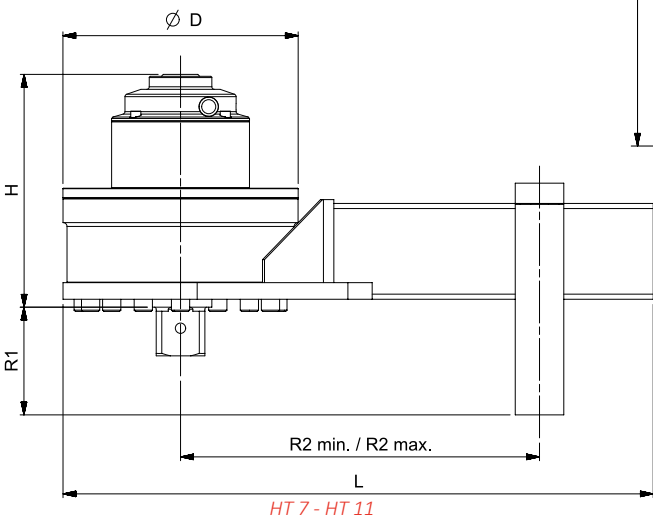
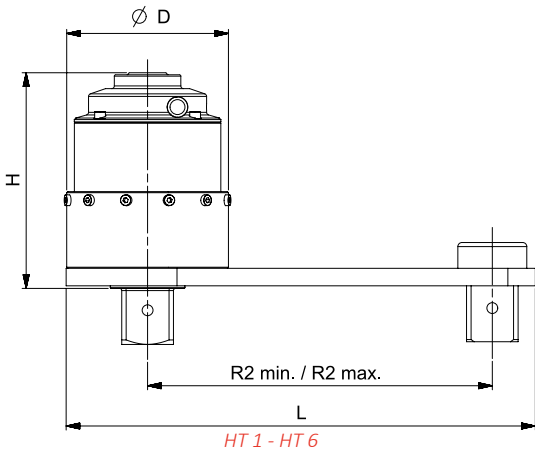



HANDTORQUE® SMALL DIAMETER SERIES



- HandTorque® models HT 30 and 60 have a higher torque output for a given gearbox diameter than the Standard Series
- Reduced diameter enables better access, particularly on pipe flanges
- Reaction taken from high strength spline
- Reaction foot can slide on the spline to allow sockets of various lengths
- If calibration is required, a UKAS accredited calibration certificate may be ordered (at extra cost)



4 SMALL DIAMETER SERIES

18006	HT 30/25 AWUR, 3,000 N·m, ½" in 1" out
18008	HT 60/25 AWUR, 6,000 N·m, ½" in 1½" out

HT 30s and 60s are supplied with a cranked reaction foot. Most small diameter gearboxes are available without AWUR. Please enquire for part numbers.

NOTE: Model name does not reflect multiplication ratios, see mean multiplication ratios below

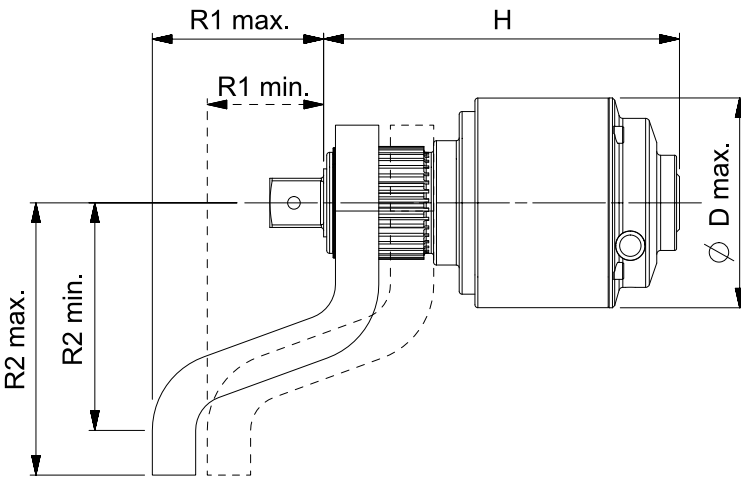

Model	HT 30/25 AWUR	HT 60/25 AWUR
Part Number	18006	18008
Mean Multiplication Ratio	27:1	27:1
Dimensions (mm)	∅D max.	108
	H	183
	R1 min.	60
	R1 max.	88
	R2 min.	117
	R2 max.	140
Tool Weight (kg)	7.0	10.6
Reaction Weight (kg)	2.0	4.0

UKAS ACCREDITED CALIBRATION CERTIFICATION

The part numbers shown below are for 'As Found', for new manual torque multiplying gearboxes up to the maximum capacity shown.

12	ONE DIRECTION
HTCC2.CW	Up to 6,000 N·m / 5,000 lbf·ft
12	TWO DIRECTIONS
HTCC2.CW+CCW	Up to 6,000 N·m / 5,000 lbf·ft





POWERED TORQUE TOOLS

Electronic Tools

EvoTorque® are electronic torque tools designed for applying torque to threaded fasteners. The unique ‘Intelligent Joint Sensing’ technology will accurately tighten to the correct torque without the risk of excess overshoot or undershoot that is common in other electric tools. EvoTorque® tools give continuous (not impacting) rotation and are quiet in use.

EvoTorque® tools utilise patented technology to give unprecedented joint control from hard through to soft joints. They are available in both mains-electric and battery-powered ranges.

On a given joint they will consistently achieve accurate, repeatable results of ±3% of the setting within the calibrated range.

Pneumatic Tools

PneuTorque® operation is quiet with absolutely no impacting. These two factors make PneuTorques comfortable for the operator to use, reducing fatigue and consequently increasing safety.

PneuTorques provide accurate torque control – on a given joint they will stall repeatably to within ±5% (PTS tools, ±3%). Using electronic shut off, this repeatability can be improved to ±2%.

The PneuTorque® consists of a robust air motor driving a Norbar multiplier with three or more stages of epicyclic gearing. This gives the advantage of smooth, continuous rotation (versus an impulsing action or the hammer action in an impacting tool). The benefits include :

- more consistent bolting,
- less damage to bolt, socket and joint, and
- reduced operator injury & fatigue.

Torque control is achieved by adjustment of the air pressure. An air pressure versus torque graph and a calibration certificate are both supplied with each tool and allows specific torque values to be set. For more critical applications, PneuTorques can be fitted with a torque transducer and the precise torque output displayed. The tool can then be shut off at the desired torque either manually or automatically using suitable control circuitry.

Models are available up to 300,000 N·m (220,000 lbf·ft).

EvoTorque®2	57
EvoTorque® Battery Tool (EBT)	61
EvoTorque® 2 & EvoTorque® Battery Tool Right Angle Gearbox	64
Pneumatic Torque Tools	65
PneuTorque® PTS™ Series	67
PneuTorque® PTS™ Right Angle Gearbox	69
PneuTorque® PTS™ Remote Series	70
PneuTorque® PTM Series	71
PneuTorque® PTM Right Angle Gearbox	73
PneuTorque® PTME-72 Series	73
ET, ET2, PTS™ and PTM Nose Extensions	74
PneuTorque® Standard Series	75
Torque Reaction	79
PTS™ and PTM Dual Trigger Module (DTM)	85
Secondary Handle	85
Right Angle Gearbox Module	86
Lubro Control Units	87
Socket Retainers	87





EVOTORQUE®2



The EvoTorque®2 is an electronic torque tool designed to accurately apply torque to threaded fasteners. Tools are factory calibrated to $\pm 3\%$ of reading. The unique 'intelligent joint sensing' technology continually measures the joint during tightening and when necessary, employs dynamic braking to avoid torque over-shoot due to motor inertia. Consequently, EvoTorque®2 can apply torque accurately over a wide range of joint rates from hard (high torque rate) through to soft (low torque rate). All EvoTorque®2 tools are highly tolerant of supply voltage and frequency variation. If the supply voltage is outside of tolerance then, as a safety feature, the tool will be prevented from starting.

The EvoTorque®2 has the ability to memorise multiple targets, work IDs, user IDs and readings. A work sequence (flow) can be performed on the EvoTorque®2, taking the user through a pre-defined tightening sequence. The tool has four modes of operation: Torque, Torque & Angle, Torque & Angle with Final Torque and Torque Audit. The unique Audit Mode is a sophisticated feature for testing pre-tightened bolts with minimal impact on the original fastening torque and can provide quality control data for monitoring joint performance over time. With accuracy and repeatability of $\pm 3\%$ of the setting, EvoTorque®2 offers many features including:

- Multiple units of torque measurement, N·m, lbf·ft, ft·lb and kgf·m
- Calibrated from 20% to 100% of tool range
- Torque, Torque & Angle and Torque Audit modes available
- In Torque & Angle Mode and Audit Mode, torque can be set from 10% of tool maximum
- Display and on-board storage of final torque or torque and angle values
- Memory capacity for 3,000 readings, time and date stamped
- Clear indication of successful joint application
- USB and Bluetooth® 4.0 data transfer (also called Bluetooth® Smart)
- Complementary PC software 'EvoLog' for data management and tool configuration
- 12 user IDs can be downloaded to the tool and results can be stored against individual users
- 20 unique stand-alone targets plus 20 unique work group targets for each work group
- Results can be output in CSV (comma-separated values) format for users not able to use EvoLog
- Very quiet : Noise level : <70dB(A)
- Vibration : Does not exceed 2.5m/s^2 (highest measured under test : 0.304m/s^2)
- Ability to produce and store real time graphs via EvoLog
- Torque & Angle with Final Torque
- 'Usage' counter gives the ability to see the amount of times the tool has been used since the last reset
- 'Operation Direction' feature designed primarily for undoing bolts. When doing sequence tightening, it is now possible to undo an incorrectly tightened bolt without interrupting the sequence
- Two stage tightening gives faster application of a Snug Torque & Angle Target
- 'Turn Angle' option can be used to check if bolts have already been tightened in an assembly process
- Tool can be integrated into third party control systems
- Two different lock levels, lock level 1 as per previous lock, lock level 2 will not allow user to exit the run screen or change the target
- Maximum Audit Mode target angle of 720°
- Supplied with a traceable calibration certificate for torque and angle as standard. Calibrated from 20% to 100% of tools maximum torque capacity, clockwise only



EVOTORQUE®2



Colour OLED display shows torque and angle values



Display can be powered up independently of tool for data transfer (via USB)



Built in Bluetooth® for wireless data transfer



Communication between tool and PC either wirelessly using Bluetooth® 4.0 or wired using supplied USB cable

EvoTorque®2's intelligent joint sensing technology always detects which type of bolt you are working with.

Hard joints

(High Torque Rate*)

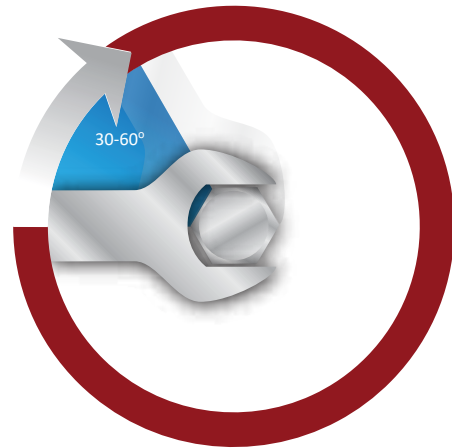

Joints completed within the range 30° - 60°

Soft joints

(Low Torque Rate*)

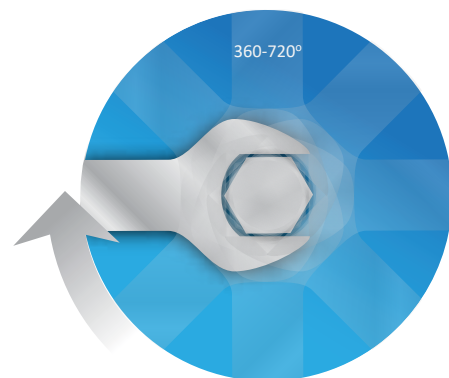

Joints completed within the range 360° - 720°

*High torque rate and low torque rate as defined by ISO 5393 'Rotary tools for threaded fasteners- Performance test method'

The EvoTorque®2 has been designed to complete joints of 30° and above to within the tools ±3% accuracy. For joints below 30° use the tools audit mode feature.



EVOTORQUE®2



Traditional electronic torque tools give vastly different results depending on the joint type. Norbar's 'intelligent joint sensing' technology eliminates these issues so that you can be confident in your bolting work.

Typical of present generation

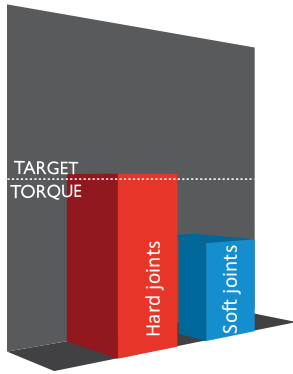

New generation EvoTorque®2

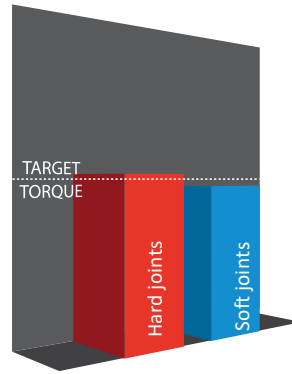

ET2-72 (1000 & 1350)

ET2-72 (2000)

ET2-80 (2700)

ET2-92 (4000)

ET2-119 (7000)

11	EVOTORQUE 2 - 110 V
180230.B06	ET2-72-1000-110, ¾" sq. dr., 200 - 1,000 N·m
180231.B06	ET2-72-1350-110, ¾" sq. dr., 270 - 1,350 N·m
180232.B08	ET2-72-2000-110, 1" sq. dr., 400 - 2,000 N·m
180239.B08	ET2-80-2700-110, 1" sq. dr., 540 - 2,700 N·m
180238.B08	ET2-92-4000-110, 1" sq. dr., 800 - 4,000 N·m
180236.B12	ET2-119-7000-110, 1½" sq. dr., 1,400 - 7,000 N·m

11	EVOTORQUE 2 - 230 V
180220.B06	ET2-72-1000-230, ¾" sq. dr., 200 - 1,000 N·m
180221.B06	ET2-72-1350-230, ¾" sq. dr., 270 - 1,350 N·m
180222.B08	ET2-72-2000-230, 1" sq. dr., 400 - 2,000 N·m
180229.B08	ET2-80-2700-230, 1" sq. dr., 540 - 2,700 N·m
180228.B08	ET2-92-4000-230, 1" sq. dr., 800 - 4,000 N·m
180226.B12	ET2-119-7000-230, 1½" sq. dr., 1,400 - 7,000 N·m

The EvoTorque®2 is supplied in a cardboard box as standard, if a sturdier case is required Norbar can provide a Peli Case at an additional charge. Please add .PEL on to the end of the part number when ordering. For tools fitted with a Right Angle Gearbox, add .RAPEL.



Standard Box



Optional Peli Case
Part No. 26969 or 26971



EVOTORQUE®2



Model	ET2-72-1000 ET2-72-1350	ET2-72-2000	ET2-80-2700	ET2-92-4000	ET2-119-7000	
Part Number	180230.B06 180220.B06 180231.B06 180221.B06	180232.B08 180222.B08	180239.B08 180229.B08	180238.B08 180228.B08	180236.B12 180226.B12	
Output Speed (rpm)	21 (ET-72-1000) 17 (ET-72-1350)	11	10	6	3.3	
Dimensions (mm)	∅D max.	72	72	80	92	119
	H1	45	45	45	45	45
	H2	317	317	317	317	317
	H3	109	109	109	109	109
	L	366	407	363	417	440
	R1	71	76	76	70	90
	R2 min. R2 max.	124 167	124 167	124 167	125 175	162 210
Tool Weight (kg)	10.4	10.8	10.8	12.9	16.8	
Reaction Weight (kg)	1.5	1.5	1.5	2.6	3.9	

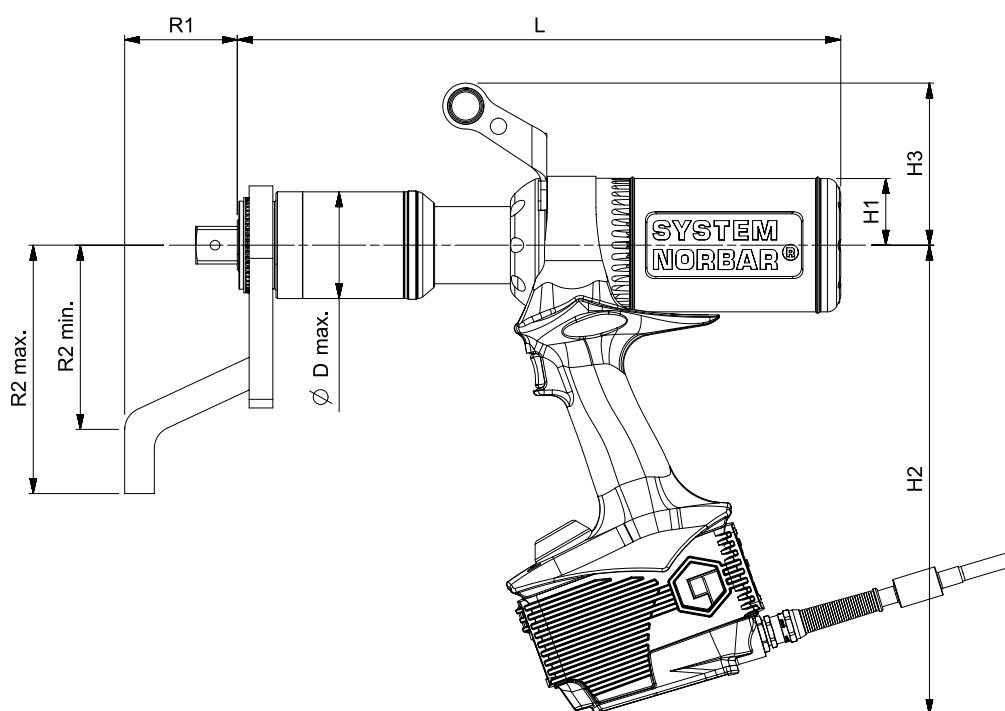

Patented in the UK and Germany (EP2699389) and in the USA (US9676086).



EVOTORQUE® BATTERY TOOL (EBT)



The EvoTorque® Battery Tool (EBT) features a new brushless motor, data memory and data transfer capabilities. Norbar has combined this with our respected gearboxes to deliver a range of fast, reliable, accurate torque tools that retain key features from our EvoTorque® 2 range (see page 57).

Fast: EBT uses a powerful motor coupled with either a single speed or auto two speed gearbox for rapid joint completion times.

Durable: The industrial motor used by the EBT gives long life with minimal motor service requirement.

Accurate: EBT is a transducer controlled battery powered torque tool designed for accurately applying torque to threaded fasteners. The unique 'intelligent joint sensing' technology continually measures the joint during tightening and when necessary, employs dynamic braking to avoid torque over-shoot due to motor inertia. Both accuracy and repeatability of $\pm 3\%$ of the setting within the calibrated range.

- Tool is not constrained by power cable or hose, improving safety, convenience and versatility
- 18V, 5.0Ah battery and efficient motor give outstanding fastening performance per charge
- 'Safe to start' button ensures hands are safely positioned at start up

Note: In some circumstances it can be difficult to support and operate the tool while simultaneously pressing the trigger and 'safe to start' button. For this reason, single trigger models are also available.

- OLED display ensures visibility in all conditions
- High powered LED to illuminate application
- Optional 'Ease of Use' functionality when in 'Torque Only' mode, minimising operator error
- Supplied with a traceable calibration certificate for torque and angle as standard. Calibrated ranges shown in the table on page 63, clockwise only
- Available in single speed ideal for torque with angle control
- Auto two speed configurations available for rapid joint completion
- Torque, Torque & Angle and Torque Audit modes available
- In Torque & Angle Mode and Audit Mode, torque can be set from a lower percentage of tool maximum on single speed tools compared to their auto two speed equivalents. Single speed tools are therefore recommended for angle operation
- Software can be updated remotely, without the need to return the product to Norbar
- Quiet : Noise level : 79.1dB(A), with an uncertainty $K = 3\text{dB}$, when free-running
- Vibration : Does not exceed 2.5m/s^2 (highest measured under test : 0.9m/s^2)



EBT display panel and 'safe to start' button



EVOTORQUE® BATTERY TOOL (EBT)



13	EBT SERIES - SINGLE SPEED - 'SAFE TO START' MODELS
180349	¾" sq. dr., 160 - 800 N·m, 118 - 600 lbf-ft, Kit
180350	¾" sq. dr., 160 - 800 N·m, 118 - 600 lbf-ft, Bare
180445*	1" sq. dr., 200 - 1,350 N·m, 150 - 1,000 lbf-ft, Kit
180446*	1" sq. dr., 200 - 1,350 N·m, 150 - 1,000 lbf-ft, Bare
180541	1" sq. dr., 400 - 2,700 N·m, 295 - 2,000 lbf-ft, Kit
180542	1" sq. dr., 400 - 2,700 N·m, 295 - 2,000 lbf-ft, Bare
180637	1" sq. dr., 800 - 4,000 N·m, 590 - 2,950 lbf-ft, Kit
180638	1" sq. dr., 800 - 4,000 N·m, 590 - 2,950 lbf-ft, Bare

13	EBT SERIES - AUTO TWO SPEED - 'SAFE TO START' MODELS
180469*	1" sq. dr., 338 - 1,350 N·m, 250 - 1,000 lbf-ft, Kit
180470*	1" sq. dr., 338 - 1,350 N·m, 250 - 1,000 lbf-ft, Bare
180565	1" sq. dr., 676 - 2,700 N·m, 499 - 2,000 lbf-ft, Kit
180566	1" sq. dr., 676 - 2,700 N·m, 499 - 2,000 lbf-ft, Bare
180661	1" sq. dr., 1,000 - 4,000 N·m, 738 - 2,950 lbf-ft, Kit
180662	1" sq. dr., 1,000 - 4,000 N·m, 738 - 2,950 lbf-ft, Bare

Tool ranges shown above are calibrated ranges, see table on page 63 for operating ranges.

* 1,350 N·m models come supplied with both a ¾" and 1" sq. dr.

NOTE: Kit versions come with tool, 2 batteries, charger and a secondary handle in a carry case. 800 N·m tools do not come with a secondary handle.

Bare tools are supplied in a cardboard box without batteries, charger and secondary handle.

Other tool variations are available, please contact Norbar for details.

When the tool is to be used for untightening bolts, Norbar recommends the selection of single speed versions. In the case of prevailing torque lock-nuts or partially tightening bolts, the Auto Two Speed version of the tools will generally give no advantage and single speed tools should be selected.



13	EBT SERIES - SINGLE SPEED - SINGLE TRIGGER MODELS
180850	¾" sq. dr., 160 - 800 N·m, 118 - 600 lbf-ft, Kit
180851	¾" sq. dr., 160 - 800 N·m, 118 - 600 lbf-ft, Bare
180898*	1" sq. dr., 200 - 1,350 N·m, 150 - 1,000 lbf-ft, Kit
180899*	1" sq. dr., 200 - 1,350 N·m, 150 - 1,000 lbf-ft, Bare
180946	1" sq. dr., 400 - 2,700 N·m, 295 - 2,000 lbf-ft, Kit
180947	1" sq. dr., 400 - 2,700 N·m, 295 - 2,000 lbf-ft, Bare
180994	1" sq. dr., 800 - 4,000 N·m, 590 - 2,950 lbf-ft, Kit
180995	1" sq. dr., 800 - 4,000 N·m, 590 - 2,950 lbf-ft, Bare

13	EBT SERIES - AUTO TWO SPEED - SINGLE TRIGGER MODELS
180922*	1" sq. dr., 338 - 1,350 N·m, 250 - 1,000 lbf-ft, Kit
180923*	1" sq. dr., 338 - 1,350 N·m, 250 - 1,000 lbf-ft, Bare
180970	1" sq. dr., 676 - 2,700 N·m, 499 - 2,000 lbf-ft, Kit
180971	1" sq. dr., 676 - 2,700 N·m, 499 - 2,000 lbf-ft, Bare
181018	1" sq. dr., 1,000 - 4,000 N·m, 738 - 2,950 lbf-ft, Kit
181019	1" sq. dr., 1,000 - 4,000 N·m, 738 - 2,950 lbf-ft, Bare

8	EBT SERIES - ACCESSORIES
266148	EBT Plastic Case with inserts
60334.EBT	EBT Battery Pack
60335.KIT	EBT Battery Charger



Single Trigger EBT display panel





EVOTORQUE® BATTERY TOOL (EBT)



EBT-52 Series



EBT-72 Series



EBT-80 Series



EBT-92 Series

Model	EBT-52-800	EBT-72-1350	EBT-72-1350 Auto Two Speed	EBT-80-2700	EBT-80-2700 Auto Two Speed	EBT-92-4000	EBT-92-4000 Auto Two Speed
Part Number	180349 180350 180850 180851	180445 180446 180898 180899	180469 180470 180922 180923	180541 180542 180946 180947	180565 180566 180970 180971	180637 180638 180994 180995	180661 180662 181018 181019
Operating Range (N·m)	100 - 800	120 - 1,350	338 - 1,350	270 - 2,700	676 - 2,700	400 - 4,000	1,000 - 4,000
Calibrated Range (N·m)	160 - 800	200 - 1,350	338 - 1,350	400 - 2,700	676 - 2,700	800 - 4,000	1,000 - 4,000
Output Speed (rpm)	11.2	6.5	32	3.3	13	2.3	9.5
Dimensions (mm)	ØD max.	52	72	80	80	92	92
	H1	40	40	40	40	40	40
	H2	262	262	262	262	262	262
	L	271	298	317	298	333	387
	R1	59	76	76	76	76	70
	R2 min.	68	124	124	124	124	125
	R2 max.	131	167	167	167	167	175
	W	90	90	90	90	90	90
Tool Weight (kg)*	3.7	5.7	5.9	5.9	6.8	7.9	8.3
Reaction Weight (kg)	0.8	1.4	1.4	1.4	1.4	2.5	2.5

* Tool weight excludes both reaction and battery. The battery weighs 0.8 kg.

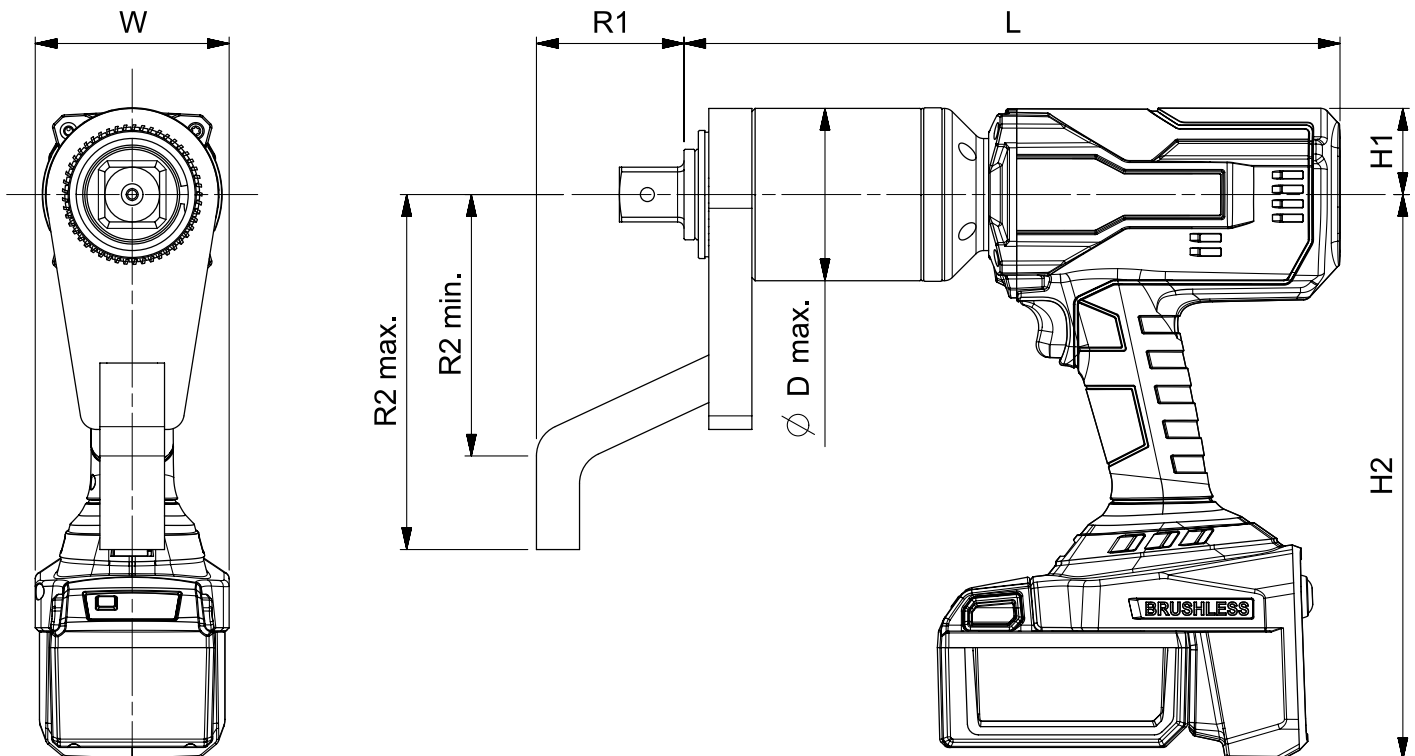

Patent applied for



EVOTORQUE® 2 & EVOTORQUE® BATTERY TOOL RIGHT ANGLE GEARBOX



Right Angle Gearbox fitted to EvoTorque®2



11	EVOTORQUE 2 - 110 V - RIGHT ANGLE GEARBOX
180230.B06.RA	ET2-72-1000-110, 3/4" sq. dr., 200 - 1,000 N·m
180231.B06.RA	ET2-72-1350-110, 3/4" sq. dr., 270 - 1,350 N·m
180232.B08.RA	ET2-72-2000-110, 1" sq. dr., 400 - 2,000 N·m
180239.B08.RA	ET2-80-2700-110, 1" sq. dr., 540 - 2,700 N·m
180238.B08.RA	ET2-92-4000-110, 1" sq. dr., 800 - 4,000 N·m
180236.B12.RA	ET2-119-7000-110, 1 1/2" sq. dr., 1,400 - 7,000 N·m

11	EVOTORQUE 2 - 230 V - RIGHT ANGLE GEARBOX
180220.B06.RA	ET2-72-1000-230, 3/4" sq. dr., 200 - 1,000 N·m
180221.B06.RA	ET2-72-1350-230, 3/4" sq. dr., 270 - 1,350 N·m
180222.B08.RA	ET2-72-2000-230, 1" sq. dr., 400 - 2,000 N·m
180229.B08.RA	ET2-80-2700-230, 1" sq. dr., 540 - 2,700 N·m
180228.B08.RA	ET2-92-4000-230, 1" sq. dr., 800 - 4,000 N·m
180226.B12.RA	ET2-119-7000-230, 1 1/2" sq. dr., 1,400 - 7,000 N·m

The EvoTorque®2 Right Angle Gearbox is supplied in a cardboard box as standard, if a sturdier case is required Norbar can provide a Peli Case at an additional charge. Please add .PEL on to the end of the part number when ordering.



Right Angle Gearbox fitted to EBT



13	EBT SERIES - SINGLE SPEED - 'SAFE TO START' - RIGHT ANGLE GEARBOX
180353	3/4" sq. dr., 160 - 800 N·m, 118 - 600 lbf·ft, Kit
180354	3/4" sq. dr., 160 - 800 N·m, 118 - 600 lbf·ft, Bare
180449*	1" sq. dr., 200 - 1,350 N·m, 150 - 1,000 lbf·ft, Kit
180450*	1" sq. dr., 200 - 1,350 N·m, 150 - 1,000 lbf·ft, Bare
180545	1" sq. dr., 400 - 2,700 N·m, 295 - 2,000 lbf·ft, Kit
180546	1" sq. dr., 400 - 2,700 N·m, 295 - 2,000 lbf·ft, Bare
180641	1" sq. dr., 800 - 4,000 N·m, 590 - 2,950 lbf·ft, Kit
180642	1" sq. dr., 800 - 4,000 N·m, 590 - 2,950 lbf·ft, Bare

13	EBT SERIES - AUTO TWO SPEED - 'SAFE TO START' - RIGHT ANGLE GEARBOX
180473*	1" sq. dr., 338 - 1,350 N·m, 250 - 1,000 lbf·ft, Kit
180474*	1" sq. dr., 338 - 1,350 N·m, 250 - 1,000 lbf·ft, Bare
180569	1" sq. dr., 676 - 2,700 N·m, 499 - 2,000 lbf·ft, Kit
180570	1" sq. dr., 676 - 2,700 N·m, 499 - 2,000 lbf·ft, Bare
180665	1" sq. dr., 1,000 - 4,000 N·m, 738 - 2,950 lbf·ft, Kit
180666	1" sq. dr., 1,000 - 4,000 N·m, 738 - 2,950 lbf·ft, Bare

* 1,350 N·m models come supplied with both a 3/4" and 1" sq. dr.

NOTE: Kit versions come with tool, 2 batteries, charger and a secondary handle in a carry case.

Bare tools are supplied in a cardboard box without batteries, charger and secondary handle.



PNEUMATIC TORQUE TOOLS

What is a PneuTorque® Pneumatic Torque Tool?

The PneuTorque® consists of a robust air motor driving a Norbar multiplier with three or more stages of epicyclic gearing.

Torque control is achieved through adjustment of the air pressure. An air pressure versus torque graph and a calibration certificate is supplied with each tool and allows specific torque values to be set. For more critical applications, PneuTorques can be fitted with a torque

transducer and the precise torque output displayed. The tool can then be shut off at the desired torque either manually or automatically using suitable control circuitry.

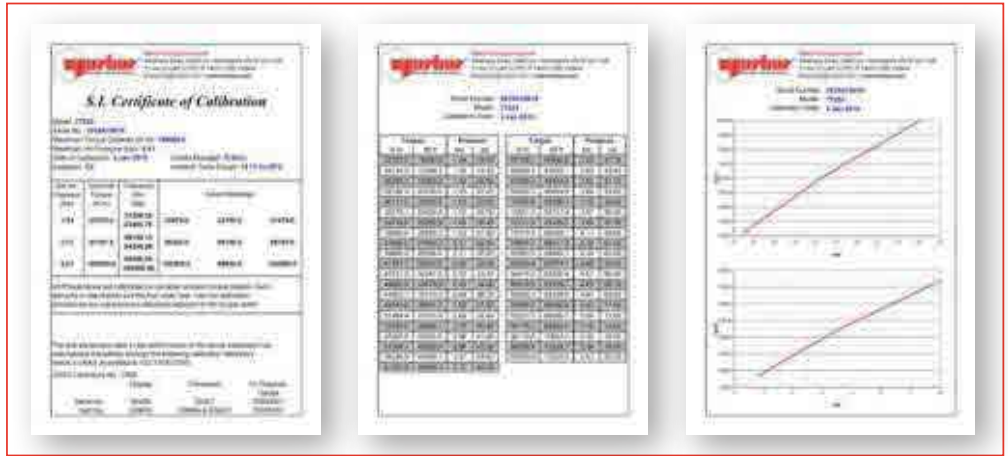

Why use PneuTorque® Pneumatic Torque Tools?

Hand operated torque multipliers are ideal for low volume or intermittent use or when there is no power source available. However, for production lines or whenever a large number of bolts is involved, a powered multiplier will save a considerable amount of time.

PneuTorque® operation is quiet – less than 84 dB(A) with absolutely no impacting. These two factors make PneuTorques comfortable for the operator to use, reducing fatigue and consequently increasing safety.

PneuTorques provide accurate torque control – on a given joint they will stall repeatably to within ±5% (PTS tools, ±3%). Using electronic shut off, this repeatability can be improved to ±2%.

Summary of PneuTorque® Advantages:

- Sound pressure level does not exceed 84 dB(A) with an uncertainty K = 3dB
- No impacting means less damage to the tool, socket and bolted assembly
- Less operator fatigue, results in increased safety
- Powerful – models available up to 300,000 N·m (220,000 lbf·ft)
- Repeatability of ±5% for accurate torque control (±3% for PTS range)
- A wide range of attachments and accessories make PneuTorques adaptable to many applications

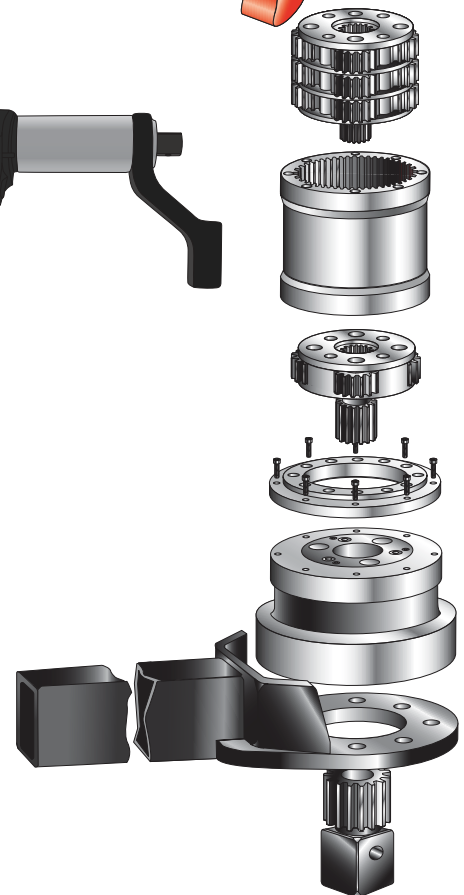
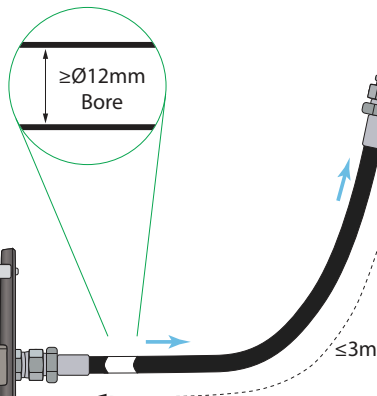
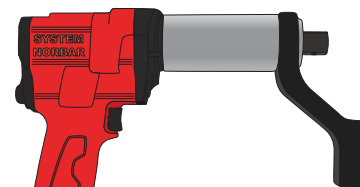
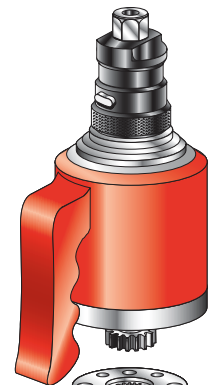



PNEUMATIC TORQUE TOOLS



PneuTorque® Applications

The smooth and continuous torque output of the PneuTorque® makes these tools suitable for a wide range of bolting and non-bolting applications.

Bolting

PneuTorques are ideally suited to tightening and untightening bolts of up to 150 mm diameter. The following is just a small selection of applications:

- Wheel nuts on trucks, buses and large machinery
- Structural steelwork
- High pressure joints e.g. Pipelines, boiler feed pumps and pressure vessels
- Engine head bolts
- Injector heads on plastic injection moulding machines
- Heat exchangers
- Heavy vehicle production eg. chassis and suspension bolts

Non-bolting

Whenever a high continuous torque is needed, PneuTorques can be used as the power source. Typical applications include:

- Valve Actuation and valve grinding
- Powering wagons and gantries
- Barring of large diesel engines (turning the crankshaft) during build
- Weld testing by applying test torques
- Roller adjustment in steel mills and paper mills
- Valving of gas bottles





PNEUTORQUE® PTS™ SERIES



The PTS™ is the result of an extensive design project to produce an efficient air motor in an accurate torque tool. The air motor is then married to Norbar's respected gearbox range, sharing common torque reaction accessories with PTM, EvoTorque® 2 and EBT.

- Pistol grip handle for operator comfort
- Designed to offer excellent power-to-weight ratio
- Easily accessible switch for forward and reverse operation
- ±3% repeatability of reading from 20% to 100% of range
- Air coupling designed for safety and rapid operation
- Quiet operation - The sound pressure level is 77 dB(A) [the PTS™ 4000 is 79 dB(A)]. Uncertainty K =3 dB
- Directional exhaust barrel directs exhaust away from operator
- Replaceable square drive
- Fast operation for rapid bolt rundown.
- Non-impacting - exceptionally low vibration levels (0.343 m/s²), make these tools comfortable and safe for operator use
- Steel reactions supplied as standard. Bespoke reactions available upon request

When the tool is to be used for untightening bolts, Norbar recommends the selection of single speed versions. In the case of prevailing torque lock-nuts or partially tightening bolts, the Auto Two Speed version of the tools will generally give no advantage and single speed tools should be selected.

11 PTS SERIES - STALL TOOLS - BI-DIRECTIONAL - SINGLE SPEED

180241.B06	¾" sq. dr., 100 - 500 N·m, 74 - 370 lbf·ft
180242.B06	¾" sq. dr., 160 - 800 N·m, 118 - 590 lbf·ft
180243.B06	¾" sq. dr., 200 - 1,000 N·m, 147 - 738 lbf·ft
180244.B08	1" sq. dr., 270 - 1,350 N·m, 200 - 1,000 lbf·ft
181454	1" sq. dr., 400 - 2,000 N·m, 295 - 1,475 lbf·ft
180246.B08	1" sq. dr., 540 - 2,700 N·m, 398 - 1,991 lbf·ft
180250.B08	1" sq. dr., 800 - 4,000 N·m, 590 - 2,950 lbf·ft
180249.B12	1½" sq. dr., 1,400 - 7,000 N·m, 1,030 - 5,200 lbf·ft

11 PTS SERIES - STALL TOOLS - BI-DIRECTIONAL - AUTO TWO SPEED

180781	¾" sq. dr., 200 - 1,000 N·m, 147 - 738 lbf·ft
180782	1" sq. dr., 270 - 1,350 N·m, 200 - 1,000 lbf·ft
180784	1" sq. dr., 540 - 2,700 N·m, 398 - 1,991 lbf·ft
180785	1" sq. dr., 800 - 4,000 N·m, 590 - 2,950 lbf·ft
180788	1½" sq. dr., 1,400 - 7,000 N·m, 1,030 - 5,200 lbf·ft





PNEUTORQUE® PTS™ SERIES



Model	PTS-52-500 PTS-52-800	PTS-72-1000 PTS-72-1350	PTS-72-1000 Auto Two Speed PTS-72-1350 Auto Two Speed	PTS-68-2000	PTS-80-2700	PTS-80-2700 Auto Two Speed	PTS-92-4000	PTS-92-4000 Auto Two Speed	PTS-119-7000	PTS-119-7000 Auto Two Speed	
Part Number	180241.B06 180242.B06	180243.B06 180244.B08	180781 180782	181454	180246.B08	180784	180250.B08	180785	180249.B12	180788	
Output Speed (rpm)	35.5 (PTS-52-500) 25.7 (PTS-52-800)	20.4 (PTS-72-1000) 14.7 (PTS-72-1350)	100 (PTS-72-1000) 75 (PTS-72-1350)	9.2	7.3	30	5.3	22	2.6	13	
Dimensions (mm)	∅D max.	52	72	72	68	80	80	92	92	119	119
	H1	30	30	30	30	30	30	30	30	30	30
	H2	243	243	243	243	243	243	243	243	243	243
	L	264	292	310	285	291	327	343	374	369	369
	R1	59	74	74	74	74	74	74	75	90	90
	R2 min. R2 max.	71 131	124 165	124 167	120 165	124 165	124 167	125 175	125 175	162 210	162 210
Tool Weight (kg)	4.2	6.2	6.28	5.35	6.2	7.45	8.59	8.89	12.5	12.80	
Reaction Weight (kg)	0.9	1.4	1.4	1.1	1.4	1.4	2.5	2.5	3.8	4.0	

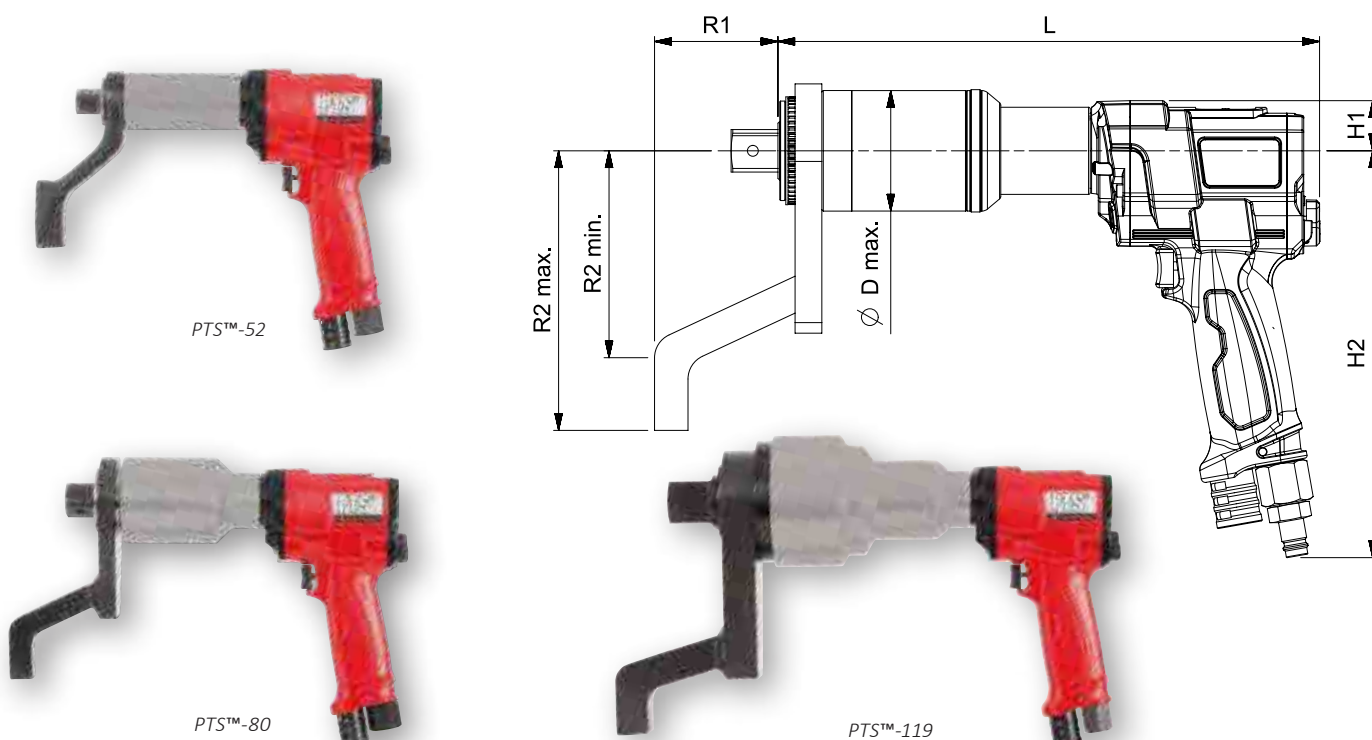



PNEUTORQUE® PTS™ RIGHT ANGLE GEARBOX



Right Angle Gearbox fitted to PTS™



11	PTS SERIES - STALL TOOLS - BI-DIRECTIONAL - SINGLE SPEED - RIGHT ANGLE GEARBOX
180241.B06.RA	3/4" sq. dr., 100 - 500 N·m, 74 - 370 lbf-ft
180242.B06.RA	3/4" sq. dr., 160 - 800 N·m, 118 - 590 lbf-ft
180243.B06.RA	3/4" sq. dr., 200 - 1,000 N·m, 147 - 738 lbf-ft
180244.B08.RA	1" sq. dr., 270 - 1,350 N·m, 200 - 1,000 lbf-ft
181454.RA	1" sq. dr., 400 - 2,000 N·m, 295 - 1,475 lbf-ft
180246.B08.RA	1" sq. dr., 540 - 2,700 N·m, 398 - 1,991 lbf-ft
180250.B08.RA	1" sq. dr., 800 - 4,000 N·m, 590 - 2,950 lbf-ft
180249.B12.RA	1 1/2" sq. dr., 1,400 - 7,000 N·m, 1,030 - 5,200 lbf-ft

11	PTS SERIES - STALL TOOLS - BI-DIRECTIONAL - AUTO TWO SPEED - RIGHT ANGLE GEARBOX
180781.RA	3/4" sq. dr., 200 - 1,000 N·m, 147 - 738 lbf-ft
180782.RA	1" sq. dr., 270 - 1,350 N·m, 200 - 1,000 lbf-ft
180784.RA	1" sq. dr., 540 - 2,700 N·m, 398 - 1,991 lbf-ft
180785.RA	1" sq. dr., 800 - 4,000 N·m, 590 - 2,950 lbf-ft
180788.RA	1 1/2" sq. dr., 1,400 - 7,000 N·m, 1,030 - 5,200 lbf-ft

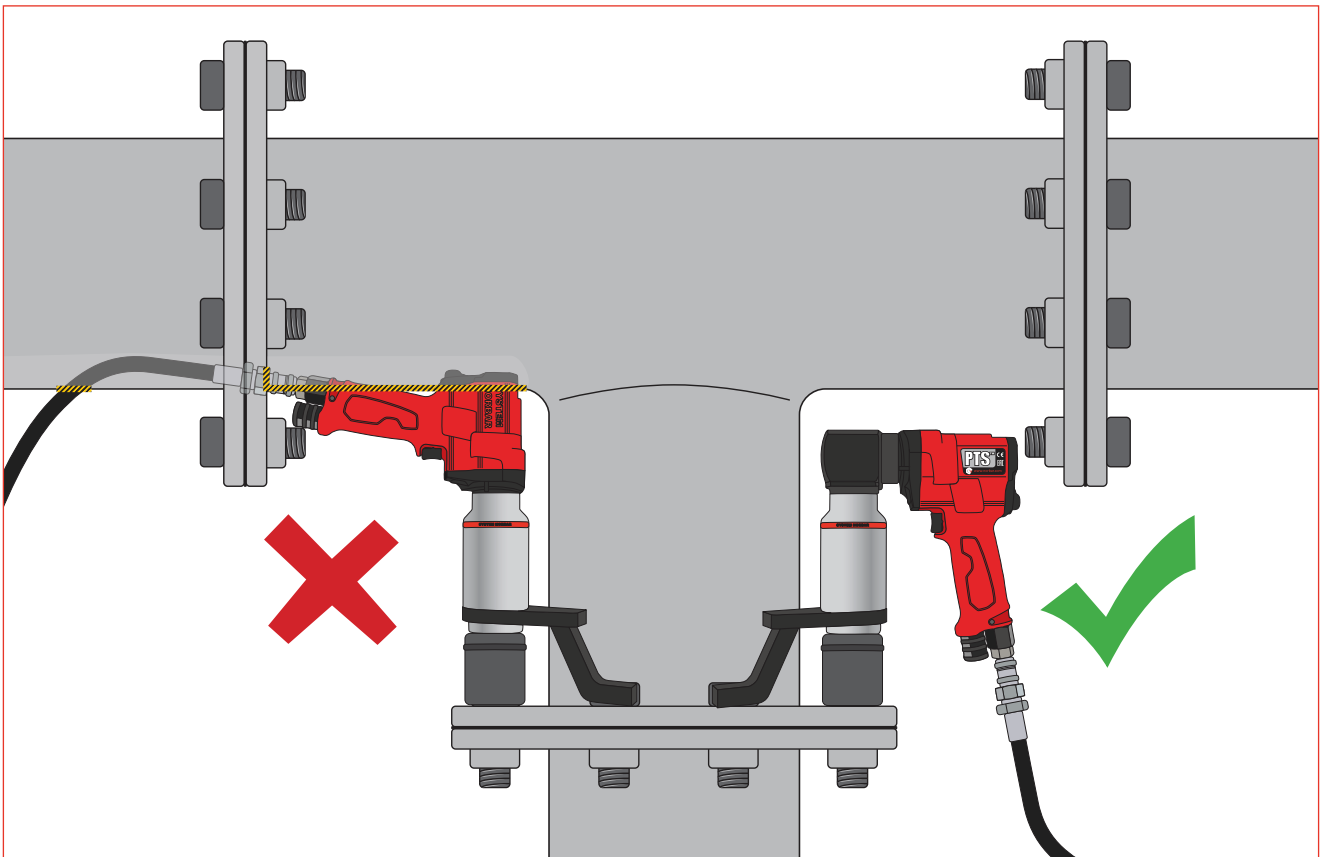



PNEUTORQUE® PTS™ REMOTE SERIES



Remote control versions have no direction control on the tool but rely on external pneumatic circuitry to provide this function. This opens up numerous application possibilities for the PneuTorque® ranging from simple stall shut-off in a hazardous working environment to sophisticated, multi-spindle torque and angle shut-off systems.

- Designed to offer excellent power-to-weight ratio
- ±3% repeatability of reading from 20% to 100% of range
- Replaceable square drive

NOTE: For full versatility, PTS™ Remotes are supplied without reaction see pages 79 - 84 for options or discuss bespoke engineered options with Norbar.

11	PTS REMOTE SERIES
180271.B06	¾" sq. dr., 100 - 500 N·m, 74 - 370 lbf-ft
180272.B06	¾" sq. dr., 160 - 800 N·m, 118 - 590 lbf-ft
180273.B06	¾" sq. dr., 200 - 1,000 N·m, 147 - 738 lbf-ft
180274.B08	1" sq. dr., 270 - 1,350 N·m, 200 - 1,000 lbf-ft
181455	1" sq. dr., 400 - 2,000 N·m, 295 - 1,475 lbf-ft
180276.B08	1" sq. dr., 540 - 2,700 N·m, 398 - 1,991 lbf-ft
180295.B08	1" sq. dr., 800 - 4,000 N·m, 590 - 2,950 lbf-ft
180279.B12	1½" sq. dr., 1,400 - 7,000 N·m, 1,030 - 5,200 lbf-ft

11	PTS REMOTE SERIES - AUTO TWO SPEED
180789	¾" sq. dr., 200 - 1,000 N·m, 147 - 738 lbf-ft
180790	1" sq. dr., 270 - 1,350 N·m, 200 - 1,000 lbf-ft
180792	1" sq. dr., 540 - 2,700 N·m, 398 - 1,991 lbf-ft
180793	1" sq. dr., 800 - 4,000 N·m, 590 - 2,950 lbf-ft
180796	1½" sq. dr., 1,400 - 7,000 N·m, 1,030 - 5,200 lbf-ft

Model	PTS REMOTE 52-500	PTS REMOTE 52-800	PTS REMOTE 72-1000	PTS REMOTE 72-1350	PTS REMOTE 68-2000	PTS REMOTE 80-2700	PTS REMOTE 92-4000	PTS REMOTE 119-7000
Part Number	180271.B06	180272.B06	180273.B06	180274.B08	181455	180276.B08	180295.B08	180279.B12
Output Speed (rpm)	27.8	20.1	16	11.5	7.2	5.7	4.1	2
Dimensions (mm)	∅D max.	52	52	72	72	68	80	92
	H1	29	29	29	29	29	29	29
	H2	78	78	78	78	78	78	78
	L	284	284	311	311	302	311	362
	W	70	70	70	70	70	70	70
Tool Weight (kg)	4.1	4.1	6.1	6.1	5.25	6.1	8.9	12.4

Model	PTS REMOTE 72-1000 Auto Two Speed	PTS REMOTE 72-1350 Auto Two Speed	PTS REMOTE 80-2700 Auto Two Speed	PTS REMOTE 92-4000 Auto Two Speed	PTS REMOTE 119-7000 Auto Two Speed
Part Number	180789	180790	180792	180793	180796
Output Speed (rpm)	78	56	22	20	10
Dimensions (mm)	∅D max.	72	72	80	92
	H1	29	29	29	29
	H2	78	78	78	78
	L	330	330	344	395
	W	70	70	70	70
Tool Weight (kg)	6.2	6.2	7.0	9.3	12.78

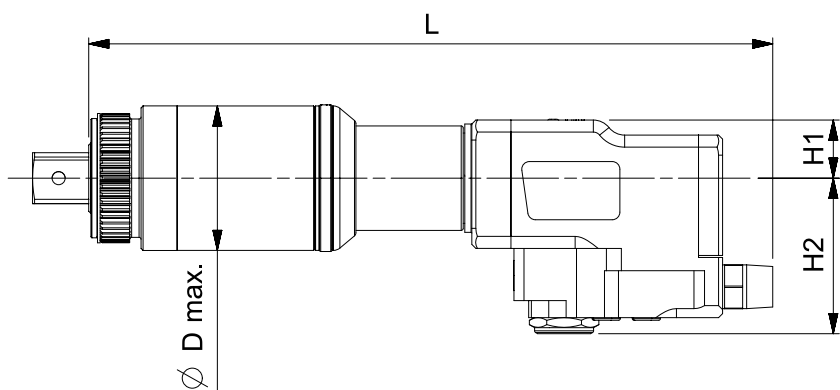
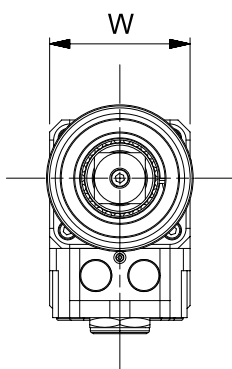



PNEUTORQUE® PTM SERIES



Using twin motor technology, the PTM series of PneuTorques is engineered to be amongst the lightest and fastest on the market. For example, the 500 N·m version has a gearbox diameter of just 52 mm, allowing excellent bolt access, and has a maximum free running speed of 224 rpm. Torque control is normally achieved by adjustment of air pressure. An air pressure versus torque graph and a calibration certificate is supplied with each tool.

- Exceptionally compact 52, 68, 72 and 80 mm gearboxes result in light, well balanced tools
- Fitted with a light robust reaction plate as standard
- Other reaction plates are available for maximum versatility
- Quiet : Noise level : 84dB(A), with an uncertainty K = 3dB, when free-running
- Vibration : Does not exceed 2.5m/s² (highest measured under test : 1.79m/s²)
- Fast operation for rapid bolt run-down
- ±5% repeatability of reading from 20% to 100% of range



11 PTM SERIES - STALL TOOLS - BI-DIRECTIONAL

18100.B06	¾" sq. dr., 100 - 500 N·m, 74 - 370 lbf-ft
18101.B06	¾" sq. dr., 160 - 800 N·m, 118 - 590 lbf-ft
18102.B06	¾" sq. dr., 200 - 1,000 N·m, 147 - 738 lbf-ft
18103.B08	1" sq. dr., 270 - 1,350 N·m, 200 - 1,000 lbf-ft
181456.B08	1" sq. dr., 400 - 2,000 N·m, 295 - 1,475 lbf-ft
180296.B08	1" sq. dr., 540 - 2,700 N·m, 400 - 2,000 lbf-ft
18159.B08	1" sq. dr., 800 - 4,000 N·m, 590 - 2,950 lbf-ft
18159.B12	1½" sq. dr., 800 - 4,000 N·m, 590 - 2,950 lbf-ft
18108.B12	1½" sq. dr., 900 - 4,500 N·m, 660 - 3,300 lbf-ft
18109.B12	1½" sq. dr., 1,200 - 6,000 N·m, 885 - 4,425 lbf-ft

Also available as forward only tools, replace B with F when ordering.





PNEUTORQUE® PTM SERIES



PTM-52



PTM-68



PTM-72



PTM-80



PTM-92



PTM-119

Model	PTM-52-500-B PTM-52-800-B	PTM-72-1000-B PTM-72-1350-B	PTM-68-2000-B	PTM-80-2700-B	PTM-92-4000-B	PTM-119-4500-B PTM-119-6000-B	
Part Number	18100.B06 18101.B06	18102.B06 18103.B08	181456.B08	180296.B08	18159.B08 18159.B12	18108.B12 18109.B12	
Output Speed (rpm)	224 (PTM-52-500-B) 148 (PTM-52-800-B)	122 (PTM-72-1000-B) 86 (PTM-72-1350-B)	58	40	32	23 (PTM-119-4500-B) 15.5 (PTM-119-6000-B)	
Dimensions (mm)	∅D max.	52	72	68	80	92	119
	H1	29	29	29	29	29	29
	H2	224	224	224	224	224	224
	H3	116	116	116	116	116	116
	L	310	342	331	335	394	415
	R1	59	68	75	80	87	118
	R2 min.	71	91	120	91	115	150
	R2 max.	131	165	165	165	205	199
Tool Weight (kg)	4.1	6.1	5.3	7.5	8.5	13.3	
Reaction Weight (kg)	0.9	0.7	1.1	1.4	1.4	2.2	

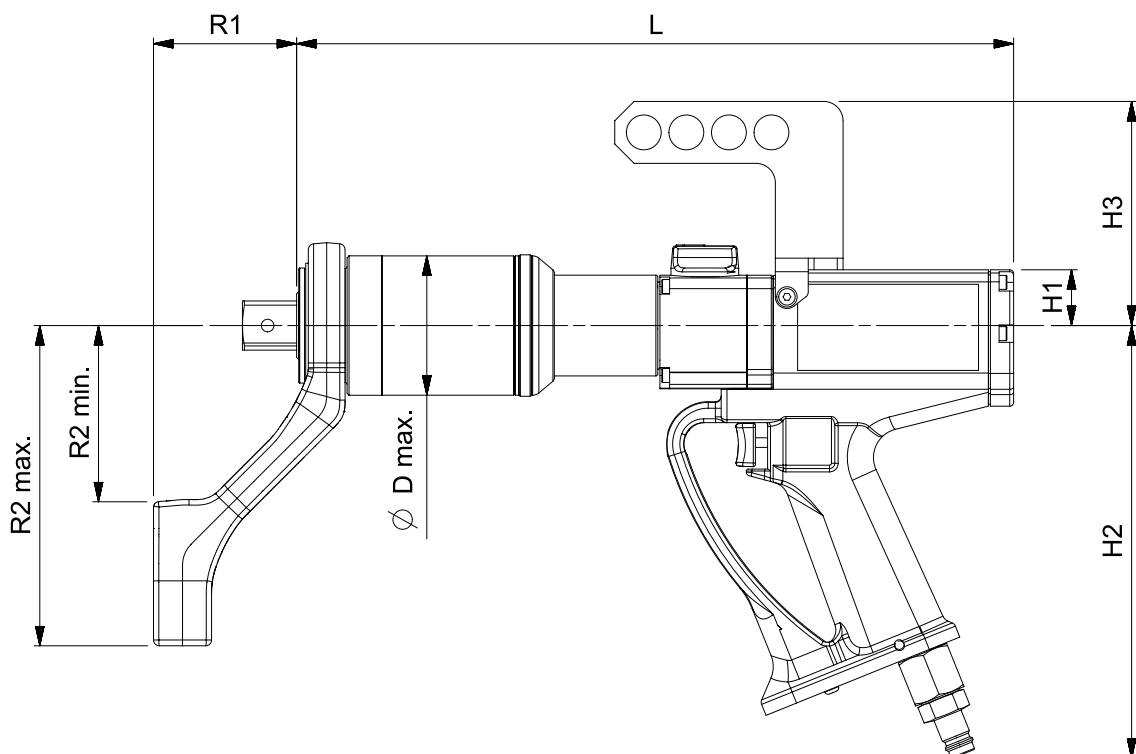



PNEUTORQUE® PTM RIGHT ANGLE GEARBOX



11 PTM-52 SERIES - STALL TOOLS - BI-DIRECTIONAL - RIGHT ANGLE GEARBOX

18100.B06.RA	¾" sq. dr., 100 - 500 N·m, 74 - 370 lbf-ft
18101.B06.RA	¾" sq. dr., 160 - 800 N·m, 118 - 590 lbf-ft

11 PTM-72 SERIES - STALL TOOLS - BI-DIRECTIONAL - RIGHT ANGLE GEARBOX

18102.B06.RA	¾" sq. dr., 200 - 1,000 N·m, 147 - 738 lbf-ft
18103.B08.RA	1" sq. dr., 270 - 1,350 N·m, 200 - 1,000 lbf-ft
181456.B08.RA	1" sq. dr., 400 - 2,000 N·m, 295 - 1,475 lbf-ft

11 PTM-80 SERIES - STALL TOOLS - BI-DIRECTIONAL - RIGHT ANGLE GEARBOX

180296.B08.RA	1" sq. dr., 540 - 2,700 N·m, 400 - 2,000 lbf-ft
---------------	-------------------------------------------------

Also available as forward only tools, replace B with F when ordering.



11 PTM-92 SERIES - STALL TOOLS - BI-DIRECTIONAL - RIGHT ANGLE GEARBOX

18159.B08.RA	1" sq. dr., 800 - 4,000 N·m, 590 - 2,950 lbf-ft
18159.B12.RA	1½" sq. dr., 800 - 4,000 N·m, 590 - 2,950 lbf-ft

11 PTM-119 SERIES - STALL TOOLS - BI-DIRECTIONAL - RIGHT ANGLE GEARBOX

18108.B12.RA	1½" sq. dr., 900 - 4,500 N·m, 660 - 3,300 lbf-ft
18109.B12.RA	1½" sq. dr., 1,200 - 6,000 N·m, 885 - 4,425 lbf-ft

Also available as forward only tools, replace B with F when ordering.

PNEUTORQUE® PTME-72 SERIES



Designed to meet the needs of the commercial vehicle market, the integrated reaction foot of the PTME-72 series of tools reaches recessed wheel bolts whilst the 72 mm diameter gearbox handles the high frequency of use demanded by busy tyre shops.

11 PTME-72 SERIES - STALL TOOLS - BI-DIRECTIONAL*

18140.B06	¾" sq. dr., 200 - 1,000 N·m, 147 - 738 lbf-ft
18149.B08	1" sq. dr., 200 - 1,000 N·m, 147 - 738 lbf-ft
18141.B08	1" sq. dr., 400 - 2,000 N·m, 295 - 1,475 lbf-ft

*Comes supplied in a carry case.
Stall tools are also available as forward only tools, replace B with F when ordering.

Model	PTME-72-1000-B	PTME-72-2000-B
Part Number	18140.B06 18149.B08	18141.B08
Output Speed (rpm)	122	58
Dimensions (mm)	ØD max.	72
	H1	29
	H2	224
	H3	116
	L	403
	R1	81
	R2 min.	63
R2 max.	110	
Tool Weight (kg)	7.2	7.7

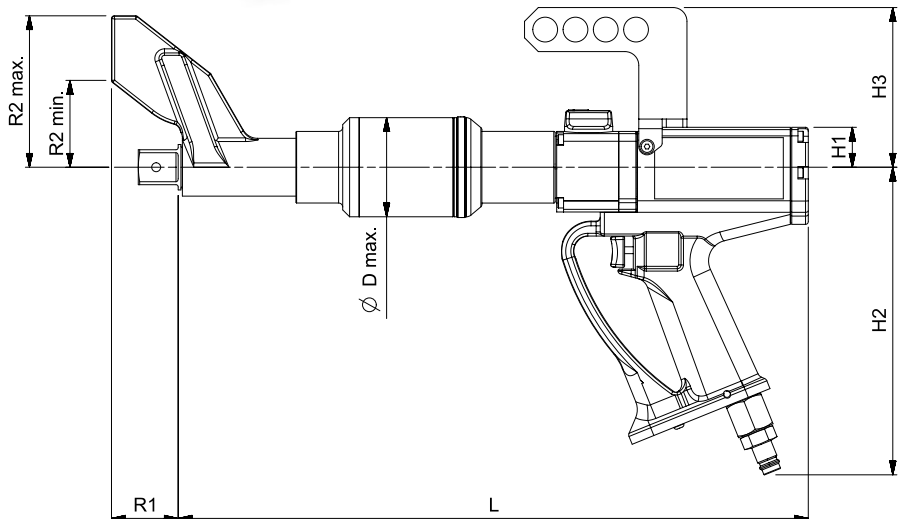



ET, ET2, PTS™ AND PTM NOSE EXTENSIONS

Special nose extension reaction devices are available for use in situations where the tool access is restricted. A typical application is the rear wheel nuts on heavy vehicles.



11 NOSE EXTENSIONS FOR 52 SERIES

18601.006	6" long, F/M 3/4" sq. dr.
18601.009	9" long, F/M 3/4" sq. dr.
18601.012	12" long, F/M 3/4" sq. dr.

F/M = Female input square/Male output square

11 NOSE EXTENSIONS FOR 72 SERIES

19007.006	6" long, SPM/M 1" sq. dr.
19007.009	9" long, SPM/M 1" sq. dr.
19007.012	12" long, SPM/M 1" sq. dr.

11 NOSE EXTENSIONS FOR 80 SERIES

19480.009	9" long, SPM/M 1" sq. dr.
19480.012	12" long, SPM/M 1" sq. dr.

SPM/M = Spline Male input/Male output square



11 SPLINED NOSE EXTENSIONS FOR 52 SERIES

19045.006	6" long
19045.009	9" long
19045.012	12" long

11 SPLINED NOSE EXTENSIONS FOR 72 SERIES 3/4" DRIVE

19046.006	6" long, 3/4" sq. dr.
19046.009	9" long, 3/4" sq. dr.
19046.012	12" long, 3/4" sq. dr.

11 SPLINED NOSE EXTENSIONS FOR 72/92 SERIES 1" DRIVE

19285.006	ET2/EBT/PTS/PTM-72 6" long, 1" sq. dr.
19285.009	ET2/EBT/PTS/PTM-72 9" long, 1" sq. dr.
19285.012	ET2/EBT/PTS/PTM-72 12" long, 1" sq. dr.
19047.006	ET2/EBT/PTS/PTM-92 6" long, 1" sq. dr.
19047.009	ET2/EBT/PTS/PTM-92 9" long, 1" sq. dr.
19047.012	ET2/EBT/PTS/PTM-92 12" long, 1" sq. dr.



The TrukTorque™ nose extension features a special curved reaction arm designed to handle bolt tightening on the front and rear wheels of trucks and buses. The design easily accommodates wheel trims and deeply recessed wheel bolts.

11 NOSE EXTENSIONS FOR TRUCK AND BUS WHEELS (Fits PTM-72)

19087.009	1,000 N·m, 9" long, 3/4" sq. dr
19087.012	1,000 N·m, 12" long, 3/4" sq. dr
19089.009	1,000 N·m, 9" long, 1" sq. dr
19089.012	1,000 N·m, 12" long, 1" sq. dr



PNEUTORQUE® STANDARD SERIES



From left to right PT 5 Remote, PT 5 Single Speed, PT 5 Automatic Two Speed and PT 5 Manual Two Speed

Based on the original PneuTorque®, the 'Standard Series' range is a direct result of over 50 years of refinement and development necessary to keep pace with the requirements of industry today.

In use in many thousands of applications worldwide PneuTorque® wrenches continue to represent the foundation of Norbar's powered tool range. Two speed models offer all the advantages of single speed versions but with the additional benefit of a run-down speed five times greater than the high torque speed setting.

- Models available for almost every bolting and torque application, up to 300,000 N·m
- Forward and reverse operation
- Quiet : Noise level : 81dB(A), with an uncertainty K = 3dB, when free running
- Vibration : Does not exceed 2.5m/s² (highest measured under test : 0.444m/s²)
- Stall control gives repeatability of ±5% on a given joint
- Other reaction styles can be designed to suit specific applications
- Electronic torque transducers can be fitted for precise torque monitoring



From left to right PT 1 Single Speed, PT 5 Single Speed, PT 9 Single Speed and PT 14 Single Speed



PNEUTORQUE® STANDARD SERIES



11	TO 100,000 N·m - SINGLE SPEED
16031	PT 1 ¾" sq. dr., 160 - 680 N·m, 120 - 500 lbf-ft
16011	PT 1 1" sq. dr., 160 - 680 N·m, 120 - 500 lbf-ft
16098	PT 1A ¾" sq. dr., 270 - 1,200 N·m, 200 - 900 lbf-ft
16097	PT 1A 1" sq. dr., 270 - 1,200 N·m, 200 - 900 lbf-ft
16013	PT 2 1" sq. dr., 515 - 1,700 N·m, 380 - 1,250 lbf-ft
16015	PT 5 1" sq. dr., 880 - 3,400 N·m, 650 - 2,500 lbf-ft
16017	PT 6 1½" sq. dr., 880 - 3,400 N·m, 650 - 2,500 lbf-ft
16066	PT 7 1½" sq. dr., 1,762 - 6,000 N·m, 1,300 - 4,500 lbf-ft
16072	PT 9 1½" sq. dr., 2,710 - 9,500 N·m, 2,000 - 7,000 lbf-ft
16046	PT 11 2½" sq. dr., 4,400 - 20,000 N·m, 3,250 - 14,700 lbf-ft
18086	PT 12 2½" sq. dr., 9,500 - 34,000 N·m, 7,000 - 25,000 lbf-ft
16052	PT 13 2½" sq. dr., 13,550 - 47,000 N·m, 10,000 - 35,000 lbf-ft
16045	PT 14 3½" sq. dr., 22,375 - 100,000 N·m, 16,500 - 73,500 lbf-ft

11	TO 9,500 N·m - AUTOMATIC TWO SPEED
16031.AUT	PT 1 ¾" sq. dr., Auto 2SP 160 - 680 N·m, 120 - 500 lbf-ft
16011.AUT	PT 1 1" sq. dr., Auto 2SP 160 - 680 N·m, 120 - 500 lbf-ft
16098.AUT	PT 1A ¾" sq. dr., Auto 2SP 400 - 1,200 N·m, 295 - 900 lbf-ft
16097.AUT	PT 1A 1" sq. dr., Auto 2SP 400 - 1,200 N·m, 295 - 900 lbf-ft
16013.AUT	PT 2 1" sq. dr., Auto 2SP 700 - 1,700 N·m, 516 - 1,250 lbf-ft
16015.AUT	PT 5 1" sq. dr., Auto 2SP 880 - 3,400 N·m, 650 - 2,500 lbf-ft
16017.AUT	PT 6 1½" sq. dr., Auto 2SP 880 - 3,400 N·m, 650 - 2,500 lbf-ft
16066.AUT	PT 7 1½" sq. dr., Auto 2SP 2,200 - 6,000 N·m, 1,622 - 4,500 lbf-ft
16072.AUT	PT 9 1½" sq. dr., Auto 2SP 2,100 - 9,500 N·m, 2,286 - 7,000 lbf-ft

MTS = Manual Two Speed. Auto 2SP = Automatic Two Speed.

Angle Encoders are available for Standard Series PTs please contact Norbar for further details.

NB: PneuTorque® PT 11 - PT 18 are supplied with a Lubro Control Unit as standard equipment.

PneuTorques PT 12, 13 and 14 are also supplied with a weld prepared reaction ring as standard. PT 13 and 14 are also supplied with a transporting trolley. PT 15 - 18 do not include output drive or reaction. These components will be engineered uniquely for each application. Remote PT part numbers are designated with an .X

e.g. PT 1 Remote is 16031.X

e.g. PT 1 Remote Auto is 16031.XAUT

For remote models, consult Norbar for prices



11	TO 300,000 N·m - MANUAL TWO SPEED
16031.MTS	PT 1 ¾" sq. dr., MTS 160 - 680 N·m, 120 - 500 lbf-ft
16011.MTS	PT 1 1" sq. dr., MTS 160 - 680 N·m, 120 - 500 lbf-ft
16098.MTS	PT 1A ¾" sq. dr., MTS 270 - 1,200 N·m, 200 - 900 lbf-ft
16097.MTS	PT 1A 1" sq. dr., MTS 270 - 1,200 N·m, 200 - 900 lbf-ft
16013.MTS	PT 2 1" sq. dr., MTS 515 - 1,700 N·m, 380 - 1,250 lbf-ft
16015.MTS	PT 5 1" sq. dr., MTS 880 - 3,400 N·m, 650 - 2,500 lbf-ft
16017.MTS	PT 6 1½" sq. dr., MTS 880 - 3,400 N·m, 650 - 2,500 lbf-ft
16066.MTS	PT 7 1½" sq. dr., 1,762 - 6,000 N·m, 1,300 - 4,500 lbf-ft
16072.MTS	PT 9 1½" sq. dr., 2,710 - 9,500 N·m, 2,000 - 7,000 lbf-ft
16046.MTS	PT 11 2½" sq. dr., 4,400 - 20,000 N·m, 3,250 - 14,700 lbf-ft
18086.MTS	PT 12 2½" sq. dr., 9,500 - 34,000 N·m, 7,000 - 25,000 lbf-ft
16052.MTS	PT 13 2½" sq. dr. 13,550 - 47,000 N·m, 10,000 - 35,000 lbf-ft
16045.MTS	PT 14 3½" sq. dr. 22,375 - 100,000 N·m, 16,500 - 73,500 lbf-ft
18089.MTS	PT 15 MTS 40,000 - 150,000 N·m, 29,500 - 110,500 lbf-ft
18090.MTS	PT 16 MTS 55,000 - 200,000 N·m, 40,500 - 147,500 lbf-ft
18088.MTS	PT 17 MTS 70,000 - 250,000 N·m, 51,500 - 184,500 lbf-ft
16054.MTS	PT 18 MTS 85,000 - 300,000 N·m, 62,500 - 221,500 lbf-ft
16490	Lifting Bracket for Standard Series (up to PT7)



PT 16 Manual Two Speed



PNEUTORQUE® STANDARD SERIES

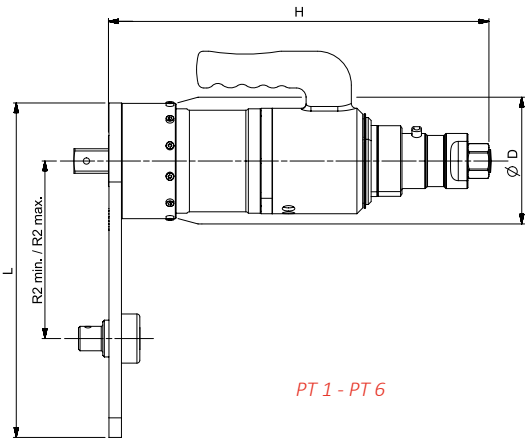

PT 1 - PT 6

PneuTorque® Standard Series Automatic Two Speed

Model	PT 1	PT 1A	PT 2	PT 5	PT 6	PT 7	PT 9
Part Number	16031.AUT 16011.AUT	16098.AUT 16097.AUT	16013.AUT	16015.AUT	16017.AUT	16066.AUT	16072.AUT
Output Speed (rpm)	150	75	45	25	25	12.5	9
Dimensions (mm)	ØD	108	108	108	119	119	184
	H	419	419	419	462	464	487
	L	303	303	303	355	355	423
	R1	N/A	N/A	N/A	N/A	N/A	84
	R2 min.	83	83	83	86	86	150
	R2 max.	216	216	216	263	263	331
Tool Weight (kg)	14.1	14.6	14.6	17.5	17.5	23.2	27.9
Reaction Weight (kg)	2.2	2.2	2.2	2.5	2.5	6.3	8.3

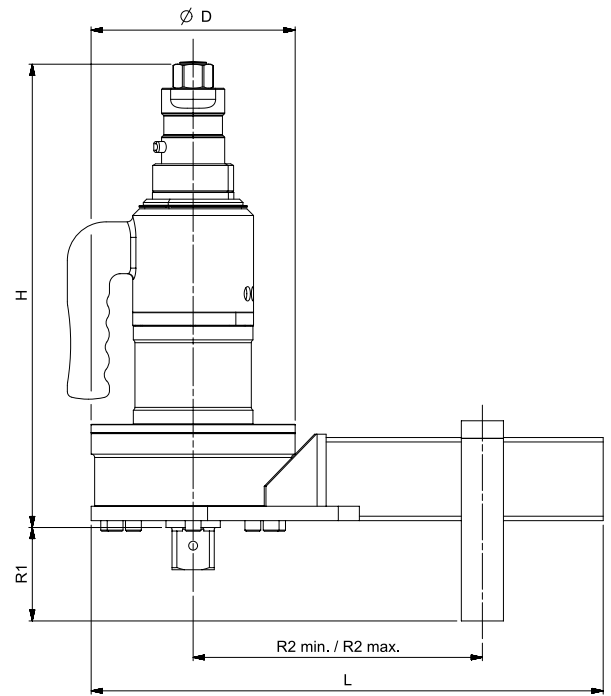

PT 7 - PT 9 (PT 11 supplied with flat reaction)

PneuTorque® Standard Series Single Speed

Model	PT 1	PT 1A	PT 2	PT 5	PT 6	PT 7	PT 9	PT 11	PT 12	PT 13	PT 14
Part Number	16031 16011	16098 16097	16013	16015	16017	16066	16072	16046	18086	16052	16045
Output Speed (rpm)	30	15	9	5	5	2.5	1.8	1.2	0.5	0.3	0.2
Dimensions (mm)	ØD	108	108	108	119	119	144	184	212	248	315
	H	350	350	350	393	395	423	418	495	536	578
	L	303	303	303	355	355	423	448	609	325	341
	R1	N/A	N/A	N/A	N/A	N/A	84	84	N/A	N/A	N/A
	R2 min.	83	83	83	86	86	150	175	320	N/A	N/A
	R2 max.	216	216	216	263	263	331	351	500	N/A	N/A
Tool Weight (kg)	10.6	11.1	11.1	14.0	14.0	19.7	24.4	38.6	49.8	102.2	
Reaction Weight (kg)	2.2	2.2	2.2	2.5	2.5	6.3	8.3	13.3	6.5	6.9	

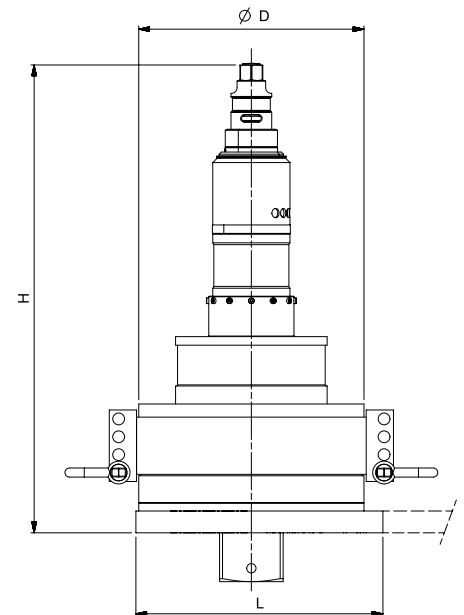

PT 12 - PT 14

PneuTorque® Standard Series Manual Two Speed

Model	PT 1	PT 1A	PT 2	PT 5	PT 6	PT 7	PT 9	PT 11	PT 12	PT 13	PT 14	PT 15	PT 16	PT 17	PT 18
Part Number	16031.MTS 16011.MTS	16098.MTS 16097.MTS	16013.MTS	16015.MTS	16017.MTS	16066.MTS	16072.MTS	16046.MTS	18086.MTS	16052.MTS	16045.MTS	18089.MTS	18090.MTS	18088.MTS	16054.MTS
Output Speed (rpm)	150	75	45	25	25	12.5	9	6	2.5	1.5	1	0.5	0.4	0.35	0.3
Dimensions (mm)	ØD	108	108	108	119	119	144	184	212	248	315	315	*	410	410
	H	436	436	436	479	481	509	504	581	622	664	729	*	866	939
	L	303	303	303	355	355	423	448	609	325	341	341	*	N/A	N/A
	R1	N/A	N/A	N/A	N/A	N/A	84	84	N/A	N/A	N/A	N/A	N/A	N/A	N/A
	R2 min.	83	83	83	86	86	150	175	320	N/A	N/A	N/A	N/A	N/A	N/A
	R2 max.	216	216	216	263	263	331	351	500	N/A	N/A	N/A	N/A	N/A	N/A
Tool Weight (kg)	14.1	14.6	14.6	17.5	17.5	23.2	27.9	42.1	53.3	105.7	122.9	*	270.0	285.0	
Reaction Weight (kg)	2.2	2.2	2.2	2.5	2.5	6.3	8.3	13.3	6.5	6.9	10.4	N/A	N/A	N/A	

* Available on request



PNEUTORQUE® STANDARD SERIES

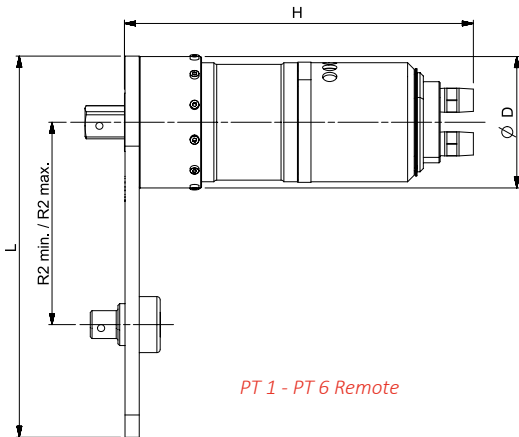

PT 1 - PT 6 Remote

PneuTorque® Standard Series Automatic Two Speed - Remote

Model	PT 1	PT 1A	PT 2	PT 5	PT 6	PT 7	PT 9
Part Number	16031.XAUT 16011.XAUT	16098.XAUT 16097.XAUT	16013.XAUT	16015.XAUT	16017.XAUT	16066.XAUT	16072.XAUT
Output Speed (rpm)	150	75	45	25	25	12.5	9
Dimensions (mm)	ØD	108	108	108	119	119	144
	H	339	339	339	382	383	412
	L	303	303	303	355	355	423
	R1	N/A	N/A	N/A	N/A	N/A	84
	R2 min.	83	83	83	86	86	150
	R2 max.	216	216	216	263	263	331
Tool Weight (kg)	14.1	14.6	14.6	17.5	17.5	23.2	27.9
Reaction Weight (kg)	2.2	2.2	2.2	2.5	2.5	6.3	8.3

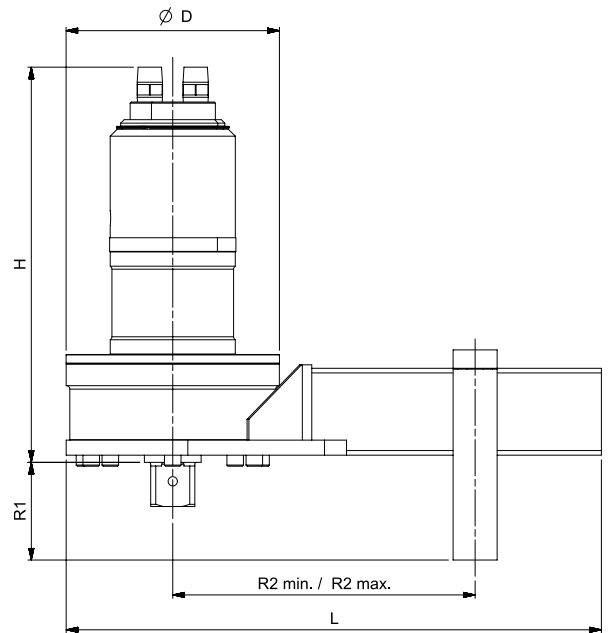

PT 7 - PT 9 Remote (PT 11 Remote supplied with flat reaction)

PneuTorque® Standard Series Single Speed - Remote

Model	PT 1	PT 1A	PT 2	PT 5	PT 6	PT 7	PT 9	PT 11	PT 12	PT 13	PT 14
Part Number	16031.X 16011.X	16098.X 16097.X	16013.X	16015.X	16017.X	16066.X	16072.X	16046.X	18086.X	16052.X	16045.X
Output Speed (rpm)	30	15	9	5	5	2.5	1.8	1.2	0.5	0.3	0.2
Dimensions (mm)	ØD	108	108	108	119	119	144	184	212	248	315
	H	270	270	270	313	314	343	340	415	456	490
	L	303	303	303	355	355	423	448	609	325	341
	R1	N/A	N/A	N/A	N/A	N/A	84	84	N/A	N/A	N/A
	R2 min.	83	83	83	86	86	150	175	320	N/A	N/A
	R2 max.	216	216	216	263	263	331	351	500	N/A	N/A
Tool Weight (kg)	10.6	11.1	11.1	14.0	14.0	17.9	24.4	38.6	49.8	102.2	
Reaction Weight (kg)	2.2	2.2	2.2	2.5	2.5	6.3	8.3	13.3	6.5	6.9	

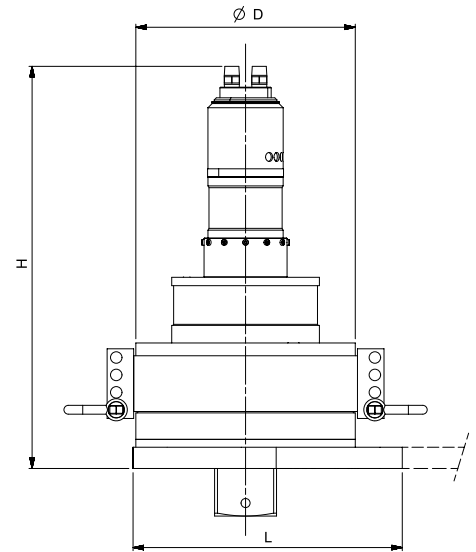

PT 12 - PT 14 Remote

PneuTorque® Standard Series Manual Two Speed - Remote

Model	PT 1	PT 1A	PT 2	PT 5	PT 6	PT 7	PT 9	PT 11	PT 12	PT 13	PT 14	PT 15	PT 16	PT 17	PT 18
Part Number	16031.XMSTS 16011.XMSTS	16098.XMSTS 16097.XMSTS	16013.XMSTS	16015.XMSTS	16017.XMSTS	16066.XMSTS	16072.XMSTS	16046.XMSTS	18086.XMSTS	16052.XMSTS	16045.XMSTS	18089.XMSTS	18090.XMSTS	18088.XMSTS	16054.XMSTS
Output Speed (rpm)	150	75	45	25	25	12.5	9	6	2.5	1.5	1	0.5	0.4	0.35	
Dimensions (mm)	ØD	108	108	108	119	119	144	184	212	248	315	315	*	410	410
	H	356	356	356	399	400	429	425	501	542	576	649	*	786	859
	L	303	303	303	355	355	423	448	609	325	341	341	*	N/A	N/A
	R1	N/A	N/A	N/A	N/A	N/A	84	84	N/A	N/A	N/A	N/A	N/A	N/A	N/A
	R2 min.	83	83	83	86	86	150	175	320	N/A	N/A	N/A	N/A	N/A	N/A
	R2 max.	216	216	216	263	263	331	351	500	N/A	N/A	N/A	N/A	N/A	N/A
Tool Weight (kg)	14.1	14.6	14.6	17.5	17.5	23.2	27.9	42.1	53.3	105.7	122.9	*	270.0	285.0	
Reaction Weight (kg)	2.2	2.2	2.2	2.5	2.5	6.3	8.3	13.3	6.5	6.9	10.4	N/A	N/A	N/A	

* Available on request



TORQUE REACTION

This page applies to both HandTorque® multipliers and powered torque tools

Principles of Torque Reaction

Newton’s law dictates that for every applied force there is an equal and opposite reactive force. For applications requiring relatively low torques that can be applied with a torque wrench, this does not present a problem as the reactive force is absorbed by the operator. However, if the desired torque necessitates the use of a multiplier, the resultant reactive force can only be absorbed using an appropriate reaction device.

For this reason all Norbar multipliers are supplied with a reaction plate or reaction foot fitted as standard.

All of the standard reaction plates and feet supplied with standard Norbar tools have been designed to enable the multiplier’s use in a variety of environments. However, due to an infinite number of bolting arrangements, it is impossible to have one reaction device that will satisfy every customer’s requirement. See pages 83 to 84 for when the supplied standard reaction is not suitable.



In the above example, 1,000 N·m torque output will result in a reactive force of 6,667 N at a point 0.15 m from the axis of rotation or 2,000 N at 0.5 m.

Avoiding Torque Reaction Problems

It has already been mentioned that the reaction force is equal to the force being applied. However, the magnitude of the reaction force is dependent upon the perpendicular distance between the point of reaction and the centre line of the multiplier, ie. the greater the distance the lower the force.

For this reason the point of reaction should be kept as far away from the centre line of the gearbox as is practical.

Customers using or modifying reaction plates for Standard Series multipliers up to a capacity of 3,400 N·m should note that if the reaction is taken on the radiused part, the reaction force is perpendicular to the tangent of the curve. Consequently, the further around the radius the reaction is taken, the smaller the perpendicular distance and therefore the greater the force.

Although a longer reaction plate may mean lower forces, the bending moment close to the multiplier will increase.

Customers extending the length of Norbar’s standard reaction plates should be aware that an increase in overall length will result in a larger induced bending stress and should not assume that because the reaction plate is strong enough at one length it will remain so when extended.

Excessive side loading, resulting from poor reaction, increases frictional forces inside the multiplier. This can lead to lower multiplication ratios (outside ±4%).

The ideal reaction arrangement has the centre of the reaction bar and the centre of the nut on a perpendicular line to the centre line of the tool.

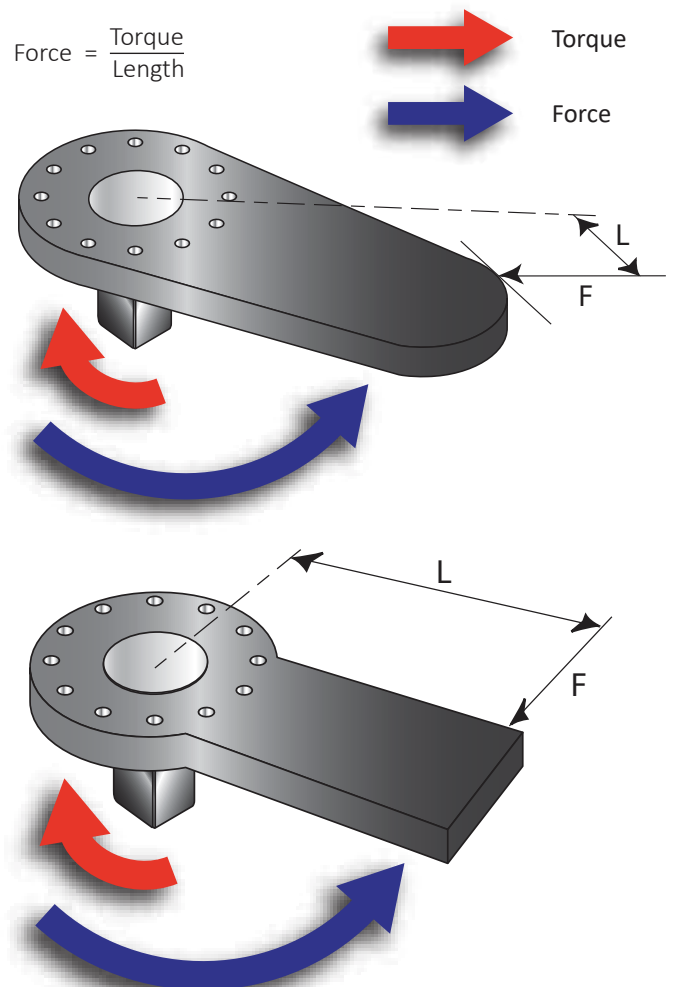



TORQUE REACTION

This page applies to both HandTorque® multipliers and powered torque tools

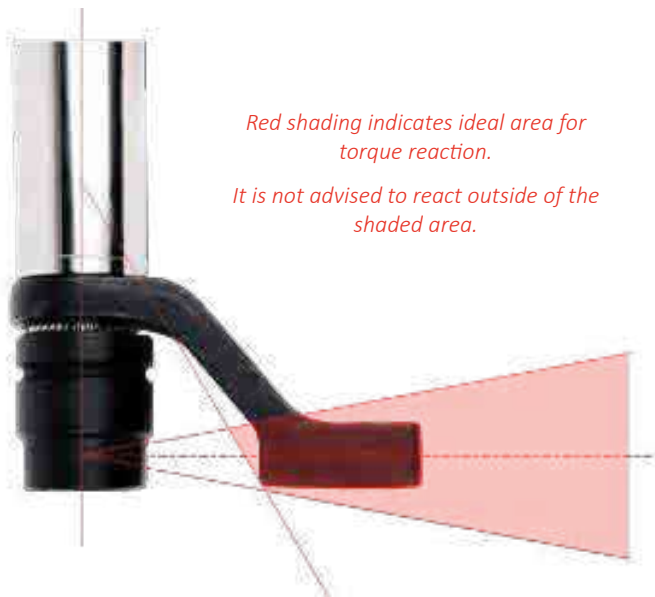

Signs of poor reaction are evident on this damaged foot. Reaction was taken at the wrong point on the foot and burring indicates that the foot was slipping off the reaction point.

Points to remember

- Take the reaction as far away from the multiplier as practical
- Ensure that the reaction point remains square to the multiplier wherever possible as this will minimise any additional stress in the output square, which could result in premature failure. If the multiplier tilts under load, the reaction may not be square
- For applications that do not allow the reaction to be taken securely it is advisable to use a double-sided or balanced reaction plate

Reaction Force

When using multipliers and PneuTorques the reaction point must be capable of withstanding the reaction force. Therefore, great care must be exercised where the reaction is taken when applying high torques to studs and bolts.

By using the following formula you can calculate the force at the point of reaction. The greater the distance the lower the force.

D = Stud Diameter

$$\text{Formula to calculate Area of Stud} = \frac{\pi \times D^2}{4}$$

$$\text{Formula to calculate shear force: Shear Force} = \frac{\text{Reaction Force}}{\text{Area of Stud}}$$

What to do if the standard reaction device is not suitable

For those applications that do not permit the use of a standard reaction plate the customer has three options.

- Norbar or an authorised Norbar distributor will design and manufacture a special purpose reaction plate to the customer's requirements
- The customer can modify the standard reaction plate to suit their requirements
- The customer can fabricate their own reaction device after liaison with Norbar's technical department or a Norbar distributor

Customers wishing to either modify the original reaction plate or fabricate their own device should read the above information on how to avoid common torque reaction problems.



TORQUE REACTION

A variety of reaction plates, manufactured in Steel or Aluminium for HandTorque®, EvoTorque®, EvoTorque® Battery Tool and PneuTorque®. Norbar also offer a range of specific reactions for the Wind Energy Generation Industry.

11 SPLINED REACTION FOR HT/PTS/PTM-52 SERIES

18646 Steel Cranked Reaction for 52 mm

11 SPLINED REACTION FOR HT/ET/EBT/PTS/PTM-72 & 80 SERIES

Steel Cranked Reaction for 72 mm and 80 mm



Aluminium Cranked Reaction for 72 mm and 80 mm



11 SPLINED REACTION FOR HT/ET/EBT/PTS/PTM-92 SERIES

Steel Cranked Reaction for 92 mm



Aluminium Cranked Reaction for 92 mm



11 SPLINED REACTION FOR HT/ET/EBT/PTS/PTM-119 SERIES

Steel Cranked Reaction for 119 mm (Max. 7,000 N-m)



Aluminium Cranked Reaction for 119 mm (Max. 6,000 N-m)

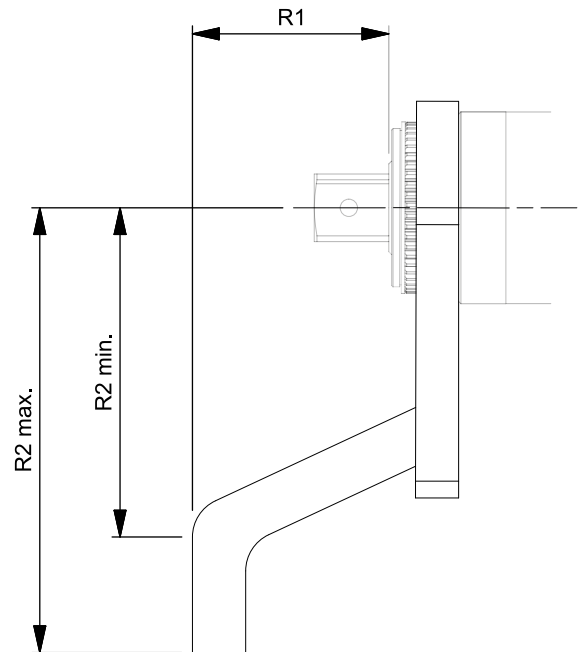

Part Number	R1	R2 min	R2 max
18646	59 mm	71 mm	131 mm
19289	76 mm	124 mm	167 mm
18494	68 mm	91 mm	165 mm
19291	70 mm	125 mm	175 mm
18936	87 mm	115 mm	205 mm
19293	90 mm	162 mm	210 mm
18961	118 mm	150 mm	199 mm



TORQUE REACTION

A variety of reaction plates, manufactured in Steel or Aluminium for HandTorque®, EvoTorque®, EvoTorque® Battery Tool and PneuTorque®. Norbar also offer a range of specific reactions for the Wind Energy Generation Industry.

11 SPECIAL SPLINED REACTION FOR HT/ET/EBT/PTS/PTM-92 SERIES

Steel Cranked Reaction for 92 mm

78028



Typical Wind Tower mid-section reaction
Part No. 78028

11 SPECIAL SPLINED REACTION FOR HT/ET/EBT/PTS/PTM-119 SERIES

Steel Cranked Reaction for 119 mm

78027



Typical Wind Tower mid-section reaction
Part No. 78027

Part Number	R1	R2 min	R2 max
78027	90 mm	148 mm	248 mm
78028	70 mm	57 mm	145 mm
78029	76 mm	45 mm	115 mm
78030	110 mm	70 mm	156 mm



Typical examples of steel crowfoot reactions
similar to 78029 and 78030

11 SPECIAL SPLINED REACTION FOR API FLANGES

78029	HT/ET/EBT/PTS/PTM-72 & 80 Series Steel Crowfoot Reaction for 1¼" – 1½"(M30 – M39) nuts/bolts
78028	HT/ET/EBT/PTS/PTM-92 Series Steel Cranked Reaction (see image on left) for 1½" – 1¾"(M42 – M48) nuts/bolts
78030	HT/ET/EBT/PTS/PTM-119 Series Steel Crowfoot Reaction for 2" – 2½"(M52 – M64) nuts/bolts



Q4714 Pegged Reaction Plate for rail

11 SPECIAL SPLINED REACTION FOR RAIL

Q4714	HT/ET/EBT/PTS/PTM-52 Series Pegged Reaction Plate Max Torque 500 N·m
Q5000	HT/ET/EBT/PTS/PTM-72 Series Pegged Reaction Plate Max Torque 1,350 N·m





TORQUE REACTION

A variety of steel reaction plates and adaptors, together with ancillary feet, blades and heads to aid their use are available for HandTorque®, EvoTorque®, EvoTorque® Battery Tool and PneuTorque®.



Reaction Adaptors
(18290 & 18558)

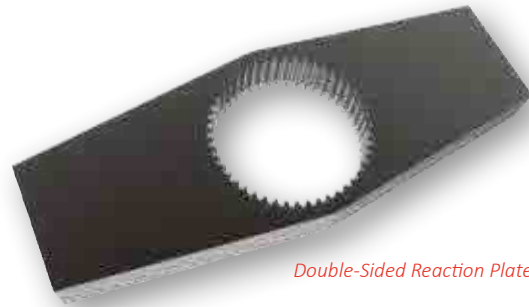

Double-Sided Reaction Plate (18293)

11	ANCILLARY ITEMS FOR USE WITH 18290 OR 18558
18558	Reaction Adaptor for HT/ET/EBT/PTS/PTM-52 Series
18290	Reaction Adaptor for HT/ET/EBT/PTS/PTM-72 Series
18298	Straight Reaction with Peg
18291	Straight Reaction
18241	Short Reaction Foot
18358	Sliding Reaction Blade (to be used with 18291)
18359	Sliding Reaction Spigot Head (to be used with 18291)

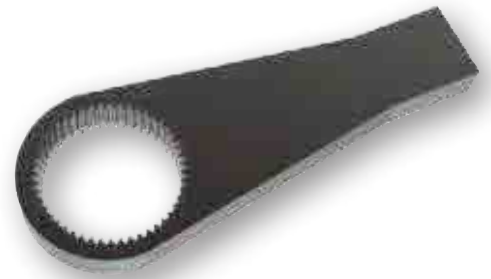

Straight Reaction
Plate (18292)

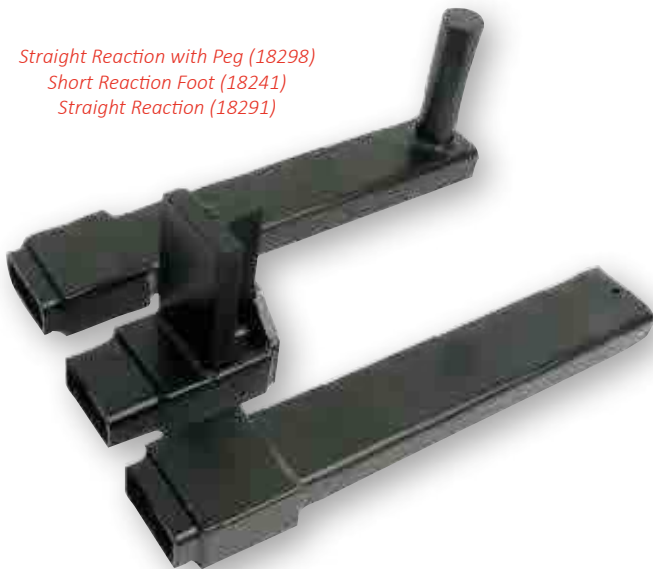

Straight Reaction with Peg (18298)
Short Reaction Foot (18241)
Straight Reaction (18291)

11	FOR HT/PTS/PTM-52 SERIES
18590	Double-Sided Reaction Plate
18576	Straight Reaction Plate
62236	Reaction Plate Spline Adaptor

11	FOR HT/ET/EBT/PTS/PTM-72 & 80 SERIES
18293	Double-Sided Reaction Plate
18292	Straight Reaction Plate

11	FOR ET/EBT/PTS/PTM-92 SERIES
18979	Straight Reaction Plate
18980	Double-Sided Straight Reaction Plate

11	FOR ET/EBT/PTM-119 SERIES
16687	Straight Reaction Plate
18981	Double Sided Straight Reaction Plate



Reaction Adaptor (18290) with Straight Reaction with Peg (18298)



TORQUE REACTION

A variety of steel reaction plates and adaptors, together with ancillary feet, blades and heads to aid their use are available for HandTorque®, EvoTorque®, EvoTorque® Battery Tool and PneuTorque®.



Sliding Reaction (180300.092.B08)



Reaction Weld Ring

11	SLIDING REACTIONS
180300.052.B06	52 mm diameter Sliding Reaction ¾" sq.
180300.072.B06	72 mm diameter Sliding Reaction ¾" sq.
180300.072.B08	72 mm diameter Sliding Reaction 1" sq.
180300.080.B08	80 mm diameter Sliding Reaction 1" sq.
180300.092.B08	92 mm diameter Sliding Reaction 1" sq.
180300.092.B12	92 mm diameter Sliding Reaction 1 ½" sq.
180300.119.B12	119 mm diameter Sliding Reaction 1 ½" sq.

11	REACTION WELD RINGS
18694	For HT/PTS/PTM-52
18695	For HT/ET/EBT/PTS/PTM-72 & 80
18696	For HT/ET/EBT/PTS/PTM-92
18697	For HT/ET/EBT/PTS/PTM-119



Sliding Spigot Reaction Plate (18436)



Light Weight Reaction (19214)

11	FOR HT 60 / PT 4500 / PT 5500
16687	Single Sided Straight Reaction Plate
18436	Sliding Spigot Reaction Plate

11	LIGHT WEIGHT REACTIONS
19214	ET/EBT/PT/PTS/PTM-72 API Class 4 Light Weight Reaction

11	FOR HT 30 / PT 2700
16686	Single Sided Straight Reaction Plate



PTS™ AND PTM DUAL TRIGGER MODULE (DTM)

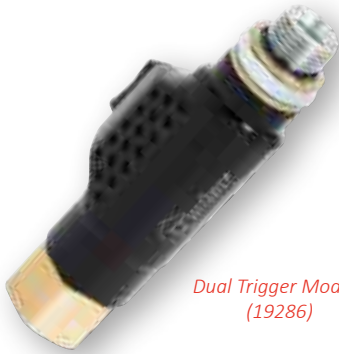

Dual Trigger Module (19286)

A secondary trigger for use with all PTS and PTM tools that easily attaches between the tool's air inlet port and hose. This requires the operator to use both hands to run the tool and so reduces the risk of hands getting trapped between the reaction bar and reaction point.

- Inlet ½" BSPP Female
- Outlet ½" BSPP Male



11	DUAL TRIGGER MODULE
19286	Dual Trigger Module for use with any PneuTorque

To order a pre-assembled tool add the suffix .DTM onto the end of the part number.

NOTE: When fitting a DTM the torque tool must be recalibrated with the DTM in place, contact Norbar for details.



SECONDARY HANDLE



The secondary handle is an easy to fit and versatile accessory which offers additional support and ease of handling when applying torque with Norbar's powered tools. The secondary handle is designed to fit directly to all new powered tools which have a handle location groove in the annulus which is covered by a red rubber band (see inset image to the right).

11	SECONDARY HANDLE
19363	For use with ET2/EBT/PTS/PTM 72, 92 & 119 Series
19448	For use with ET2/EBT/PTS/PTM 80 Series
Not suitable for use with ET2/EBT/PTS/PTM 52 and 68 Series	





RIGHT ANGLE GEARBOX MODULE



Right Angle Gearbox (180280)

Right Angle Gearbox (180280) fitted to EBT

The Right Angle Gearbox Adaptor will provide most ET, EBT, PTS™ and PTM tools with a 90° angle of operation, enabling the benefits of Norbar’s pneumatic and electric torque tools to be brought to a host of applications from which they are currently excluded due to space restrictions.

- Allows more comfortable operation of these tools on vertical bolting applications at chest height and above as the pistol grip is presented correctly to the operator
- The tool handle can rotate 360° in relation to the Right Angle Gearbox allowing the most comfortable and safest position to be found
- The handle and Right Angle Gearbox can index in relation to the tool gearbox meaning that reaction forces are not passed back to the operator
- Manufactured from steel, the Right Angle Gearbox is robustly constructed for durability and long life
- The Right Angle Gearbox can be purchased as a stand-alone product and retrofitted to existing Norbar tools by suitably qualified technicians. Norbar recommend tool recalibration after a Right Angle Gearbox has been fitted but where this is not possible, an efficiency of 97% can be assumed

11	RIGHT ANGLE GEARBOX
180280	Right Angle Gearbox Module

To order a pre-assembled ET2, PTS and PTM tool add the suffix .RA onto the end of the part number. Part numbers for a pre-assembled EBT can be found on page 64.

The EvoTorque®2 can also be supplied in a Peli Case pre-assembled to a Right Angle Gearbox at an additional charge. Please add .RAPEL onto the end of the EvoTorque®2 part number.

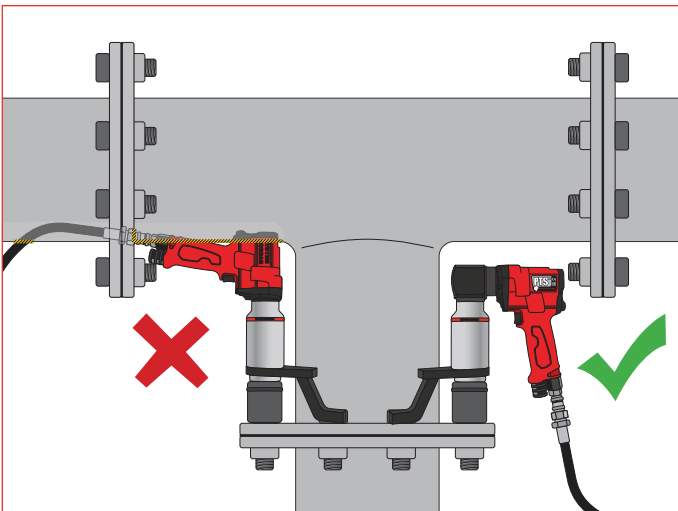



LUBRO CONTROL UNITS



Lubro Control Unit, part numbers 16074 and 60339

Norbar's standard filter, regulator, lubricator unit 16074 and 60339 feature a 100 mm diameter gauge for easy and accurate setting of air pressure with ergonomic placement of air pressure adjustment control. Supplied with 3 metres of robust, steel braided air hose with fittings to connect to PneuTorque® wrenches.

Twin Regulator Lubro Control Unit, part number 16075

The 'Twin Lubro' has the same features as Norbar's standard filter, regulator, lubricator unit but has the benefit of two regulators and a switch that allows quick selection between two air pressure settings. A typical application for this would be a PneuTorque® user wishing to quickly select between two applications requiring different torque settings. For example, this might be controlled torque in the forward direction and maximum torque allowed by the tool in the reverse direction.

Multi Channel Lubro, part number 60290

The Multi Channel Lubro is for users who wish to run their pneumatic tools at multiple air pressure settings, without having to make time consuming adjustments to an air regulator. The Multi Channel Lubro can be programmed for up to 15 air pressure settings and these settings can be locked by the removal of the programming key. A typical application would be a tyre shop servicing various vehicles, each vehicle having a different wheel nut torque. Settings can be recorded on a write-on label situated on the front of the Lubro Control. The Multi Channel Lubro is battery powered with a battery life of approximately 16 hours under normal use.



16074



16075



60290

11	LUBRO CONTROL UNITS
16074	Lubro Control Unit with 3 m hose
60339	MPa only gauged Lubro Control Unit with 3 m hose
16075	Twin Lubro Control Unit with 3 m hose

See page 144 for Lubro Control Unit spares.

SOCKET RETAINERS



These socket retaining clips make attaching sockets to square drives easy and quick.

8	SOCKET RETAINING CLIPS
19556	Socket Retaining Clip for 3/4" sq. dr. (Yellow) - Pack of 10
19557	Socket Retaining Clip for 1" sq. dr. (Red) - Pack of 10
19558	Socket Retaining Clip for 1 1/2" sq. dr. (Green) - Pack of 10
19559	Socket Retaining Clip for 2 1/2" sq. dr. (Blue) - Pack of 10



This product is intended for general purpose use at ground level. It is not intended as a solution for socket retention when working at height or where FOD (foreign object damage) could cause a safety and/or commercial risk.

Not recommended for use with impact tools.



TORQUE MEASUREMENT

Norbar started manufacturing electronic torque measuring instruments in the early 1970s and now offers a comprehensive range, from the easy to use, cost-effective TruCheck™ 2 through to the sophisticated T-Box™ 2. Norbar’s torque measuring instruments are renowned for high accuracy and superb reliability. Indeed, many of those early instruments are still in regular use today. For our interchangeable transducer instruments, we remain one of the few manufacturers in the world that issue a UKAS accredited calibration certificate both for the instrument and for the torque transducer. In doing so, customers can swap combinations of instrument and transducer while retaining complete traceability.

Norbar’s torque transducers have established an excellent reputation based on exceptional quality and accuracy. A very wide torque range is covered, 0.04 to 300,000 N·m and three basic transducer configurations are offered; Static, Impulse Rotary and Annular.

All transducers up to 100,000 N·m are supplied as standard with a UKAS accredited calibration certificate from Norbar’s in-house laboratory.

For customers who wish to take advantage of Norbar’s transducers but have an existing, non-Norbar display instrument, transducers can be provided with a mV/V calibration.

Norbar’s instruments and transducers are complemented by a wide range of ancillary products. Within this group are the products that would be required to set up a torque calibration laboratory, for example, torque wrench calibrators meeting ISO requirements and precision beam and weight systems for calibration of torque transducers.

- Torque Measurement 89
- TruCheck™ 2 90
- T-Box™ 2 93
- Torque Screwdriver Tester (TST) 95
- Torque Tool Tester (TTT) 96
- Professional Torque Tester (PRO-TEST) 97
- Spares for Instrumentation Products 98
- Static Transducer Bench Stands 98
- Static Transducers 99
- Rotary Transducers 102
- Flange Mounted Transducers (FMT) 103
- Annular Transducers 105
- Transducer Leads 107
- ISO 3000 Loader 108
- Torque Wrench Calibrator - Manual 109
- Torque Wrench Calibrator - Ancillaries 110
- Torque Wrench Calibrator - Auto 111
- Test Rigs and Fixtures 113





TORQUE MEASUREMENT

Measurement and Calibration - Glossary of Terms

The following information may help in selecting the appropriate measuring device for your needs.

Accuracy

The precision of the instrument which can be reported in three ways:

1. By quoting the guaranteed tolerance as a percentage of the reading or indicated value (eg. '0.5% of reading').
2. By quoting the guaranteed tolerance as a percentage of the full scale value of the instrument (eg. 0.1% FS or 0.1% FSD).
3. By quoting a 'class' of device in accordance with BS7882:2017 'Method for calibration and classification of torque measuring devices'.

Modes of Operation

First Peak of Torque - when a 'click type' torque wrench signals that the set torque has been achieved, the applied torque will momentarily drop before climbing again. Generally the fastener stops rotating at point 1 and from a standstill, the breakaway torque to achieve further rotation of the fastener will be higher than point 3b. Only if the operator is very insensitive to the break point will the final tightening effort be incorrect.

'First Peak of Torque' mode will detect the break point of the torque wrench, not the highest torque applied.

Peak Torque - this mode of operation will record the highest torque applied. In the case of a 'click type' torque wrench this may be higher than the actual break point if the wrench continues to be loaded beyond the break.

Consequently, Peak Torque is more useful for calibrating devices without a break signal such as dial or electronic wrenches.

Track - this mode has no memory at all. When the load is removed the display will return to zero.

Track is used for calibrating the device itself or for monitoring a fluctuating torque.

Resolution

The smallest measurement interval that can be determined on the indicating device. This applies to analogue and digital devices.

Number of Digits

Digital displays are described as having a certain number of 'digits' or 'active digits'. Half digits can be used to increase the resolution of a device without the expense of going to an additional full active digit.

Example 1. 1,000 N·m displayed on a 4 digit system would read 1000 (resolution = 1 N·m).

Example 2. 1,000 N·m displayed on a 4½ digit system would read 1000.0 (resolution = 0.1 N·m).

Active digits change as the torque changes. Non-active digits only assist in showing the magnitude of the torque. For example, 10,000 N·m requires 5 digits to display its magnitude.

Example 3. With 4 active digits (and 1 passive digit), 10,000 N·m would change in steps of 10 N·m.

Example 4. With 4½ or 5 active digits, 10,000 N·m would change in steps of 1 N·m.

Signal Processing

Electronic circuitry falls broadly into two types, analogue and digital, with most electronic measurement systems comprising a mixture of the two. There are also whole analogue electronic systems, but these are rare in torque measurement. Most systems start with an analogue signal. The point at which the signal is converted defines the type.

Analogue systems – one in which the signal is processed before being converted to digital.

Digital systems – the original analogue signal is converted to digital before processing.

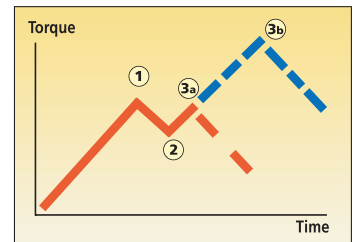

- 1 = Torque wrench activates
- 2 = 'Click' heard
- 3a = Wrench released quickly
- 3b = Wrench released slowly



TRUCHECK™ 2



This cost-effective torque wrench checker has been redesigned to incorporate improved features whilst maintaining ease of use. The TruCheck™ 2 aims to cut the cost of purchasing a torque wrench checking system and remove the fears over the complexity of using such equipment.

- Enables torque wrench performance to be monitored as part of your strategy to keep wrenches in peak condition
- LCD display with clear target indication from colour changing display (Plus version only). Visible in poorly lit work areas.
- Two versions, TruCheck™ 2 and TruCheck™ 2 Plus available
- 'Basic' version has limited settable options. Ideal for non-expert users with click type torque wrenches
- TruCheck™ 2 Plus allows a selection of torque units, three modes of operation (Click, Dial and Track), the ability to store up to 15 targets and select from 12 languages
- Plus version allows operator to set a target value and tolerance
- ±1% of reading accuracy (±2% when below 10% of range for the 10 N·m and 1,100 N·m TruCheck™ 2 model)
- Inbuilt Micro USB 2.0 port enables power from any USB power source. Plus version allows for both power and data transfer simultaneously
- Supplied with traceable calibration certificate in clockwise direction. A counter-clockwise calibration is available at additional cost
- Software can be updated remotely, without the need to return the product to Norbar



TruCheck™ 2 Plus display showing above target tolerance



TruCheck™ 2 Plus display showing within target tolerance



TruCheck™ 2 Plus display showing below target tolerance





TRUCHECK™ 2 (0.1 - 30 N·m)



TruCheck™ 2 Plus 3 N·m



TruCheck™ 2 with Torque Screwdriver (not included)

4	TRUCHECK 2 (0.1 - 30 N·m)
43514*	TruCheck 2, 0.1 - 3 N·m
43515*	TruCheck 2 Plus, 0.1 - 3 N·m
43516*	TruCheck 2, 0.5 - 10 N·m
43517*	TruCheck 2 Plus, 0.5 - 10 N·m
43518*	TruCheck 2, 1.5 - 30 N·m
43519*	TruCheck 2 Plus, 1.5 - 30 N·m
TCACC.CW	UKAS accredited calibration all sizes- clockwise
TCACC.CW+CCW	UKAS accredited calibration all sizes- clockwise and counter-clockwise

* 43514, 43515, 43516 and 43517 supplied with ¼" male hexagon and ¼" female sq. dr. adapter
 † 43518 and 43519 supplied with 10 mm male hexagon, ¼" and ⅜" female sq. dr. adapter

NOTE: If you order a UKAS accredited calibration, this certificate will be provided in place of the traceable calibration certificate and over the operating range as indicated on the device.

Model	TruCheck 2/Plus 0.1 - 3.0 N·m 0.5 - 10 N·m	TruCheck 2/Plus 1.5 - 30 N·m	
Part Number	43514, 43515, 43516, 43517	43518, 43519	
Range	0.1 - 3.0 N·m 0.5 - 10 N·m	1.5 - 30 N·m	
In-Built Transducer Male Hex Drive Size	¼"	10 mm	
Dimensions (mm)	A	175	175
	B	10	10
	ØC	6.5	6.5
	D	55	55
	E	10	10
	F	64	64
	G	N/A	72
	H	64	64
J	72	N/A	
Weight (kg)	1.4	1.4	

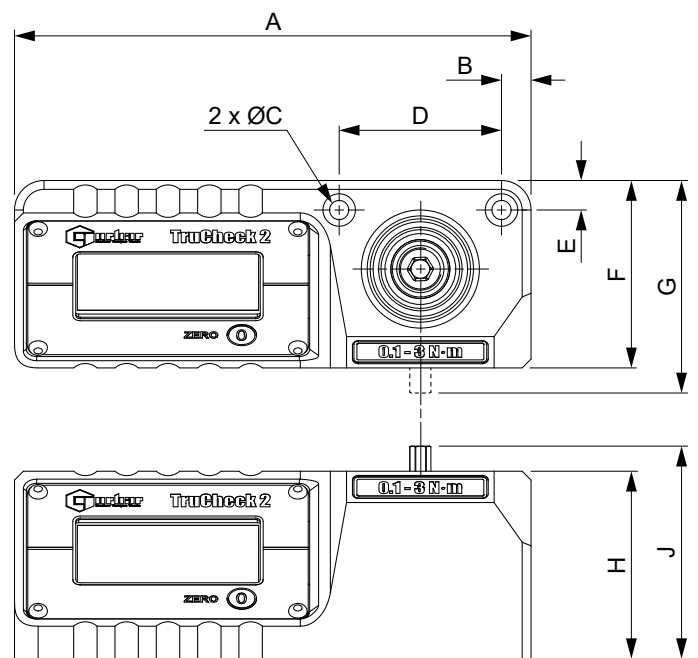

NOTE: The male hexagon on the 3 N·m and 10 N·m models is vertically aligned. The 30 N·m model male hexagon is horizontally aligned.



TRUCHECK™ 2 (3 - 2,100 N·m)



4	TRUCHECK 2 (3 - 2,100 N·m)
43520*	TruCheck 2, 3 - 65 N·m
43521*	TruCheck 2 Plus, 3 - 65 N·m
43522+	TruCheck 2, 10 - 260 lbf·ft
43523+	TruCheck 2 Plus, 10 - 260 lbf·ft
43524+	TruCheck 2, 10 - 350 N·m
43525+	TruCheck 2 Plus, 10 - 350 N·m
43528®	TruCheck 2, 40 - 800 lbf·ft
43529®	TruCheck 2 Plus, 40 - 800 lbf·ft
43530®	TruCheck 2, 50 - 1,100 N·m
43531®	TruCheck 2 Plus, 50 - 1,100 N·m
43532^	TruCheck 2, 200 - 2,100 N·m
43533^	TruCheck 2 Plus, 200 - 2,100 N·m
TCACC.CW	UKAS accredited calibration all sizes - clockwise
TCACC. CW+CCW	UKAS accredited calibration all sizes - clockwise and counter-clockwise

- * 43520 and 43521 supplied with 3/8" female square drive
- + 43522, 43523, 43524 and 43525 supplied with 1/2" female square drive
- ® 43528, 43529, 43530 and 43531 supplied with 27 mm male hexagon plus 3/4" female sq. dr. adapter
- ^ 43532 and 43533 supplied with 27 mm male hexagon plus 1" female sq. dr. adapter

NOTE: If you order a UKAS accredited calibration, this certificate will be provided in place of the traceable calibration certificate and over the operating range as indicated on the device.



TruCheck™ 2 Plus 1100 shown with a Power Tool Test Fixture (not included - see page 113) allowing for cost-effective checking of power tools

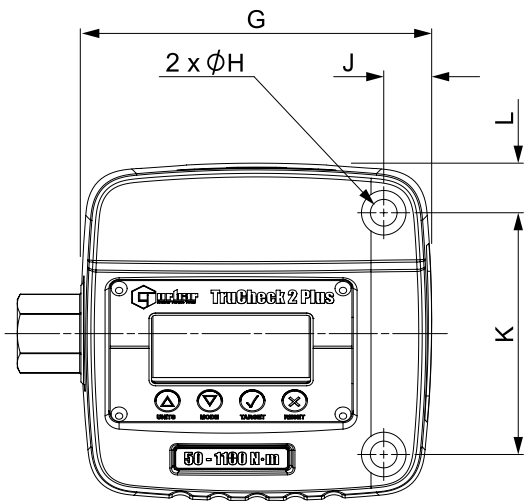
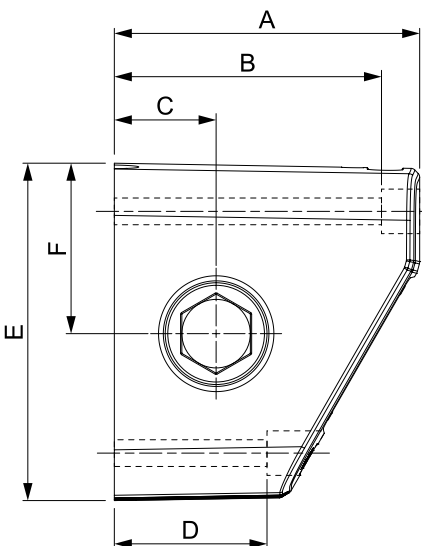

TruCheck™ 2 Plus
1,100 N·m



TruCheck™ 2 Plus
350 N·m

Model	TruCheck 2/Plus 3 - 65 N·m 10 - 260 lbf·ft 10 - 350 N·m	TruCheck 2/Plus 40 - 800 lbf·ft 50 - 1,100 N·m 200 - 2,100 N·m
Part Number	43520, 43521, 43522, 43523, 43524, 43525	43528, 43529, 43530, 43531, 43532, 43533
Dimensions (mm)	A	110
	B	95
	C	40
	D	50
	E	117
	F	59
	G	138
	ØH	10.5
	J	19
	K	80
	L	19
Weight (kg)	2.6	3.5



T-BOX™ 2



61908 TDMS USB Flash Drive

The T-Box™ 2 utilises its powerful processor to provide a seamless and complete torque data collection package. This is capable of tool calibrations, data logging, simultaneous transducer connections and archiving to your PC. As standard T-Box™ 2 is supplied with a UKAS accredited bi-directional calibration certificate recording each input as an independent channel.

- Instrument accuracy of $\pm 0.05\%$ ($\pm 0.1\%$ when below 10% of transducer capacity)
- System accuracy with a typical Norbar transducer, $\pm 0.5\%$ from 20% of transducer capacity
- 5 digit resolution when used with any Norbar transducer
- Features a 10.1" multi-touch screen display with on-screen graphic icons for simple and easy tool navigation and selection
- Features hardened and impact resistant glass helping to prevent chips and scratches appearing on the screen's surface
- 2 transducer ports gives you the ability to perform 2 tasks simultaneously e.g. graphing & measuring
- Two task windows allows simultaneous working! Measure against a target while graphing the cycle, take readings from two transducers simultaneously, capture two different graphs at the same time or manage and review readings as they are captured
- The T-Box™ 2 can capture graphs up to 325 Hz, offering the ability to analyse fast moving transients
- User configurable to allow a selection of torque, torque and angle, rate targets and the ability to set thresholds
- Ability to predefine multiple targets
- 2 USB ports, 1 RS-232 serial port and 2 independantly configurable ancillary ports

- Includes 6 modes for torque tool measurement: Track, Click, Dial & Electronic, Stall, Screwdriver and Hydraulic
- File browser/manager for internal storage and USB management giving the user greater ease and flexibility in managing multiple files and folders
- Can export readings and graphs to CSV and JSON format allowing for 3rd party software integration
- Ability to network via USB adapter
- Continuous output of up to 100 readings per second via RS-232 or USB virtual serial devices
- Fast CPU frequency up to 2.3 GHz
- Large capacity memory of 120 GB SSD storage
- 4GB RAM allows for smooth and seamless operation
- Bench stand supplied as standard with an adjustable viewing angle
- Rear panel features 100 mm x 100 mm VESA mounting holes, allowing for easy wall mounting or the use of third party stands / arms
- Software can be updated remotely, without the need to return the product to Norbar
- Fully supports the use of a keyboard and mouse (not supplied)

4	T-BOX 2
43542	T-Box 2 Instrument with TDMS Software



Displaying 2 transducer readings simultaneously



Storage destination (left) file browser (right)



Home menu for 2 separate windows



T-BOX™ 2

Calibration details



Norbar's AnB modules are a key differentiator between the T-Box™ 2 and other torque measuring instruments, including others from Norbar. While they may have the appearance of regular transducer inputs, they are actually distinct computing modules which operate independently and contain their own states and settings. For instance, when we talk about mode settings for T-Box™ 2, we do so in the context of each AnB module, as it is the module which is set in that mode and uses those settings. The T-Box™ 2 contains two AnB modules which are displayed separately using a split screen. Where this really comes into its own is when the activity on one AnB needs to be compared, graphed for example, against the activity on the other AnB. A good application for this would be the calibration of hydraulic torque wrenches where one AnB is configured to read a torque transducer and the other is configured to read a pressure transducer, allowing the user to build up a torque versus pressure graph using one instrument.



Software version 1.0.2.x available

- Ability to set up new graph pre-sets and defaults, saving the user time
- New graphing settings allows the user to set a maximum graph duration to stop data capture after a designated time
- Can link targets with the ability to delete previously captured result
- Intelligent target file history memorises the last-used files for individual AnB modules improving convenience when working with two transducers with different sets of targets at once
- Ability to enable or disable implicit AnB selection allowing for greater control when setting or clearing targets in AnB modules
- Users can now toggle serial data output on/off per AnB allowing the ability to suppress output from one AnB and leaving only the data stream from the AnB of interest
- Progressive Reset lets you sweep through a series of Linked Targets for the purpose of rapidly calibrating hydraulic wrenches or gearboxes, (peak-type modes only)
- Broadcast Capture Triggers lets you trigger capture of a reading on the neighbouring AnB when a reading capture is made on the target (peak-type and click modes only; peak-type modes require Progressive Reset to be enabled)
- Combining Progressive Reset and Broadcast Capture Triggers with Linked Targets to capture hydraulic wrench torque at a series of desirable pressure levels for rapid hydraulic wrench calibration. This approach can dramatically reduce calibration times (for instance, from several minutes to under 1 minute)
- Capture large numbers of readings with more fluidity than ever before thanks to performance optimisations in the user interface
- Simplified update procedure allowing for updates within T-Box™ 2 User Interface without the requirement of a keyboard

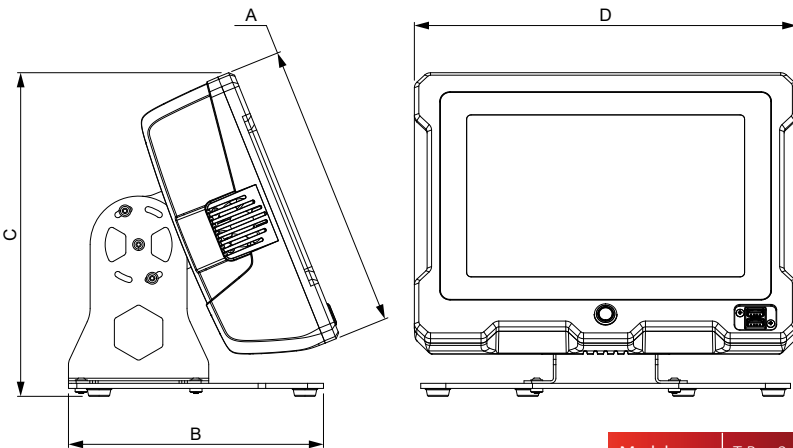

Displaying transducer reading alongside target selection

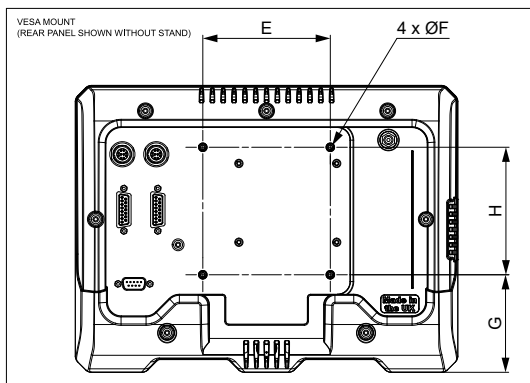

T-Box™ 2 back panel allows for 2 transducers to connect simultaneously, 1 RS-232 serial port and 2 ancillary ports

Model	T-Box 2	
Part Number	43542	
Dimensions (mm)	A	225
	B	200
	C	254
	D	300
	E	100
	ØF	M4
	G	76
H	100	
Weight (kg)	5.2	



T-Box™ 2 at the center of a test bench for manual torque wrenches, powered torque tools and hydraulic torque wrenches



TORQUE SCREWDRIVER TESTER (TST)

Calibration details



The Torque Screwdriver Tester (TST) combines simplicity and functionality to provide a high quality instrument for the testing and calibration of low capacity torque tools.

The TST is supplied as standard with a UKAS accredited torque calibration certificate in CW direction for the complete system i.e. Supplied with Instrument certificate and internal transducer system certificate.

Featuring an internal transducer complete with Rundown Fixture, the TST is available in 3 torque ranges, 0.04 to 2 N·m, 0.5 to 10 N·m and 1.25 to 25 N·m. Class 1 system accuracy over its Primary range ($\pm 0.5\%$ of reading from 20% to 100% of full scale).

What makes the TST genuinely versatile is the interface for an external transducer. This interface, accessed by a 2 way switch on the TST, allows the connection of any transducer from Norbar's Smart range and most mV/V calibrated transducers from Norbar or other manufacturers.

- Instrument accuracy of $\pm 0.05\%$ ($\pm 0.1\%$ when below 10% of transducer capacity)
- System accuracy with internal transducer or a typical external Norbar transducer, $\pm 0.5\%$ from 20% of transducer capacity
- Pictorial display panel for easy mode selection
- Limit detection with low, pass and fail indication. Up to 12 target values can be set
- Digital limit state output for control of external tools
- Operation from fast charge internal battery pack (maximum time of 3 hours 20 minutes for full charge) or a.c. supply (90 to 264 Volts)
- RS-232-C serial data interface for connection to a printer or PC. Continuous RS-232 output when used in Track mode (up to 11 readings per second)
- Pulse count feature in Impulse mode and Clutch Tool mode
- Smart intelligence for transducer recognition
- Memory for calibration details of 20 non-Smart mV/V calibrated transducers
- Analogue output allows the instrument to be used as part of a process control system for performance analysis
- User-selectable frequency response for each mode of operation
- All user-selectable features have password protection. The instrument can be issued to users with only the required modes of operation and units of measure enabled. This feature can virtually eliminate operator induced errors
- $\frac{1}{4}$ " female hex to $\frac{1}{4}$ " female square adaptor comes supplied as standard



4	TST SERIES 2
43212	TST 2, 0.04 - 2 N·m
43213	TST 10, 0.5 - 10 N·m
43214	TST 25, 1.25 - 25 N·m
TST.CCW	UKAS-accredited counter-clockwise calibration when ordered with new unit

Above part numbers exclude Transducer lead for external transducer (see page 107).

TST is supplied complete with a Rundown Fixture for joint simulation. Additional rundowns are available see page 104.



Model	All Models	
Part Number	43212 43213 43214	
Dimensions (mm)	A	290
	ØB	10
	C	40
	D	32
	E	123
	F	160
	G	61
	H	149
Weight (kg)	4.7	

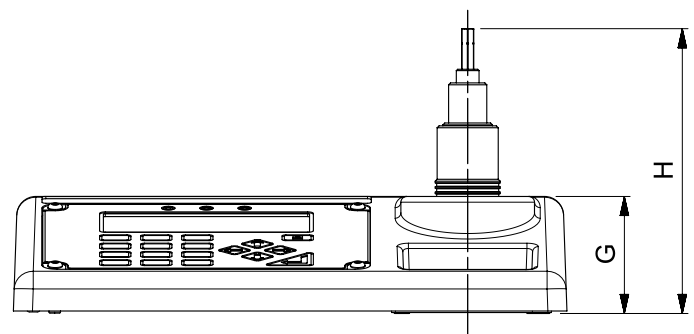
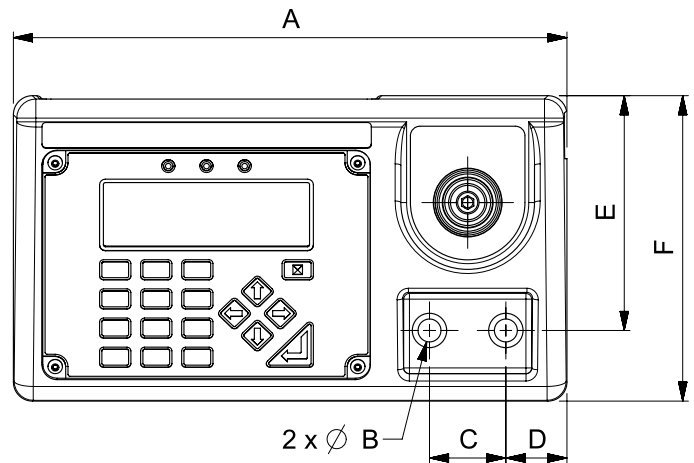



TORQUE TOOL TESTER (TTT)

Calibration details



The Torque Tool Tester (TTT) shares all of the extensive features of the Torque Screwdriver Tester (TST) except that it has no internal transducer. Instead, the TTT offers not one but three external transducer interfaces allowing any three transducers to be simultaneously connected. Selection between the transducers is made by a rotary switch at the back of the instrument case.

The TTT is supplied as standard with a UKAS accredited calibration certificate in CW direction.

Any transducer from Norbar's Smart range and most mV/V calibrated transducers from Norbar or other manufacturers can be connected to the TTT. The Smart feature means that once a transducer has been connected, the instrument will automatically recognise calibration details such as mV/V output, serial number and capacity.

- Instrument accuracy of $\pm 0.05\%$ ($\pm 0.1\%$ when below 10% of transducer capacity)
- System accuracy with a typical Norbar transducer, $\pm 0.5\%$ from 20% of transducer capacity
- Pictorial display panel for easy mode selection
- Limit detection with low, pass and fail indication. Up to 12 target values can be set
- Digital limit state output for control of external tools
- Operation from fast charge internal battery pack (maximum time of 3 hours 20 minutes for full charge) or a.c. supply (90 to 264 Volts)
- RS-232-C serial data interface for connection to a printer or PC. Continuous RS-232 output when used in Track mode (up to 11 readings per second)
- Pulse count feature in Impulse mode and Clutch Tool mode
- Smart intelligence for transducer recognition, now displays transducer capacity, units and Serial Number
- Memory for calibration details of 20 non-Smart mV/V calibrated transducers
- Analogue output allows the instrument to be used as part of a process control system for performance analysis
- User-selectable frequency response for each mode of operation
- All user-selectable features have password protection. The instrument can be issued to users with only the required modes of operation and units of measure enabled. This feature can virtually eliminate operator induced errors
- Peak memory modes can now be configured to have auto reset (previously only manual reset was possible)
- Series 3 users can set up their own measurement units, making it possible to interface with non-torque transducers, for example load or pressure



4	TTT SERIES 3
43228	TTT Instrument
TTT.CCW	UKAS-accredited counter-clockwise calibration when ordered with new unit

Above part number excludes Transducer leads (see page 107)



Model	All Models	
Part Number	43228	
Dimensions (mm)	A	152
	B	181
	C	200
Weight (kg)	4.8	

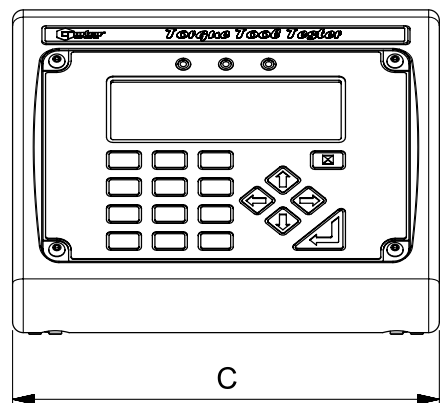
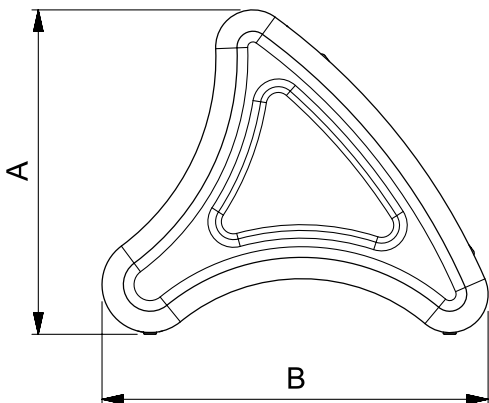



PROFESSIONAL TORQUE TESTER (PRO-TEST)

Calibration details



The Professional Torque Tester (Pro-Test) - Series 2, is an accurate, highly specified and easy to operate instrument for testing and calibrating all types of torque wrench.

The Pro-Test is supplied as standard with a UKAS accredited calibration certificate.

- Pro-Test is priced to make in-house testing a viable proposition even for the smaller industrial and automotive torque wrench user
- Guaranteed classification to BS7882:2017, Class 1 or better over the primary calibration range (20% to 100% of full scale), Class 2 or better over the secondary calibration range (lowest calibrated value to 20% of full scale). Class 1 equates to $\pm 0.5\%$ of reading
- Three essential operating modes allow the Pro-Test to be used with all torque wrench types 'Track' displays the live value, 'Peak Memory' records the highest value and 'First Peak Memory' records the first peak of torque (for click type torque wrenches). Both memory modes can be used with manual or automatic reset
- Large backlit display is easily visible from a distance and in poor light
- Display and transducer are hard-wired together with a 600 mm cable
- All common units of torque measurement are included
- Pictorial mode selection incorporated for ease of use
- User can select the language they wish to work in (most European languages are included)
- Transducer can be mounted for torque wrench operation in the horizontal or vertical plane
- RS-232-C is included for the output of reading to a printer, PC, data capture unit, SPC software etc
- Optional mounting plate gives greater flexibility of mounting options
- All user-settable parameters are menu selectable from the front panel
- Supplied in a robust carry case with a data transfer lead to connect to a PC or printer
- All transducers are supplied as standard with a UKAS accredited calibration certificate in CW direction. For additional counter-clockwise direction order: Part No. PROTEST.CCW



4	PRO-TEST SERIES 2
43218	Pro-Test 60, 1.2 - 60 N·m
43219	Pro-Test 400, 8 - 400 N·m
43220	Pro-Test 1500, 30 - 1,500 N·m

4	ANCILLARY PRODUCTS FOR PRO-TEST
62198.BLK9005	Mounting Bracket
60253	12v DC Power Supply for Series 2
29190	1" x 36 mm socket
29179	3/4" x 36 mm socket
29143	1/2" x 36 mm socket
29083	3/8" x 36 mm socket
PROTEST.CCW	Counter-clockwise calibration when ordered with new unit



Model	Pro-Test 60	Pro-Test 400	Pro-Test 1500
Part Number	43218	43219	43220
Socket(s) provided	1/4" to 10 mm Hex 3/8" to 10 mm Hex 1/2" to 10 mm Hex	3/8" to 22 mm Hex 1/2" to 22 mm Hex 3/4" to 22 mm Hex	3/4" to 36 mm Hex
Dimensions (mm)	ØA	12	12
	B	55	55
	C	183	183
	D	18	18
	E	70	70
	F	185	185
	G	233	233
	H	106	106
Weight (kg)	6.3	6.4	7.3

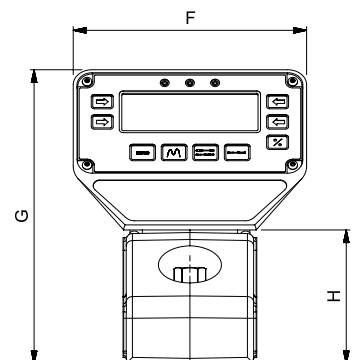
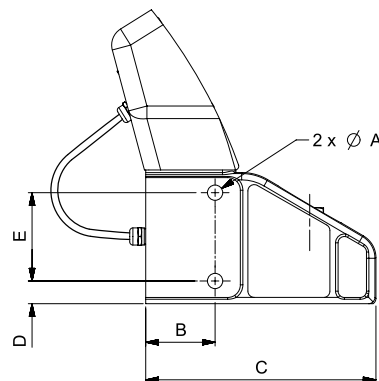



SPARES FOR INSTRUMENTATION PRODUCTS

8	SPARES FOR INSTRUMENTATION PRODUCTS
38876	Rechargeable Battery Pack for Pro-Log, TST & TTT
29610	¼" Female - ½" Male Sleeve Adaptor
29611	½" Female - ¾" Male Sleeve Adaptor
29612	½" Female - 1" Male Sleeve Adaptor
29613	¾" Female - 1" Male Sleeve Adaptor
29614	¾" Female - ½" Male Sleeve Adaptor

4	SERIAL DATA LEAD KIT
60248	Serial Data Lead Kit

Note: Serial Data Lead Kit is not suitable for use with HE Instrument and TruCheck™ 2

60259 | USB to Serial Data Lead (Does not work with USM)
 This kit enables Norbar 'CE Marked' instruments (Post January 1996 ETS, TWA and DTS plus all Pro-Test, TST and TTT) to connect to most PCs.

PART NUMBER SUFFIX SYSTEM

Transducers can be ordered for use with Norbar's current range of instruments (TST, TTT, TTL-HE and T-Box™ 2), and as Industry Standard (mV/V calibrated) for certain display instruments from other manufacturers.

A part number suffix system is used to identify the type of calibration required. For example, a 1,000 N·m Static Transducer for use with a TTT instrument would become part number 50772.LOG.

SUFFIX	USAGE	CERTIFIED IN
.LOG	TST, TTT, TTL-HE & T-Box™ 2	Torque Units
.IND	Instruments of non Norbar manufacture (check with Norbar for suitability) and TST, TTT, TTL-HE & T-Box™ 2	mV/V

Where the transducer suffix .LOG is used, the transducer is calibrated with an instrument, as a system, a calibration certificate is provided in torque units. A full scale mV/V figure is also supplied.

STATIC TRANSDUCER BENCH STANDS

4	BENCH STANDS FOR STATIC TORQUE TRANSDUCERS
50211	Small frame size (10 N·m) ¼" sq.
50212	Small frame size (50 N·m) ⅜" sq.
50213	Small frame size (100/250 N·m) ½" sq.
50220	Large frame size (250/500 N·m) ¾" sq.
50221	Large frame size (1,000/1,500 N·m) 1" sq.
50127.BLK9005*	Extra large size (7,000 N·m) 1½" sq.
52014	¼" Insert for Small Bench Stands
52015	⅜" Insert for Small Bench Stands
52016	½" Insert for Small Bench Stands
52017	¾" Insert for Large Bench Stands
52018	1" Insert for Large Bench Stands

* Dimensions available on request



Model	Small Frame Size	Large Frame Size
Part Number	50211 50212 50213	50220 50221
Dimensions (mm)	A	70
	B	120
	C	150
Weight (kg)	0.8	2.5

Bench stands ensure the correct mounting of Norbar's Static Torque Transducers up to 7,000 N·m (5,000 lbf·ft).

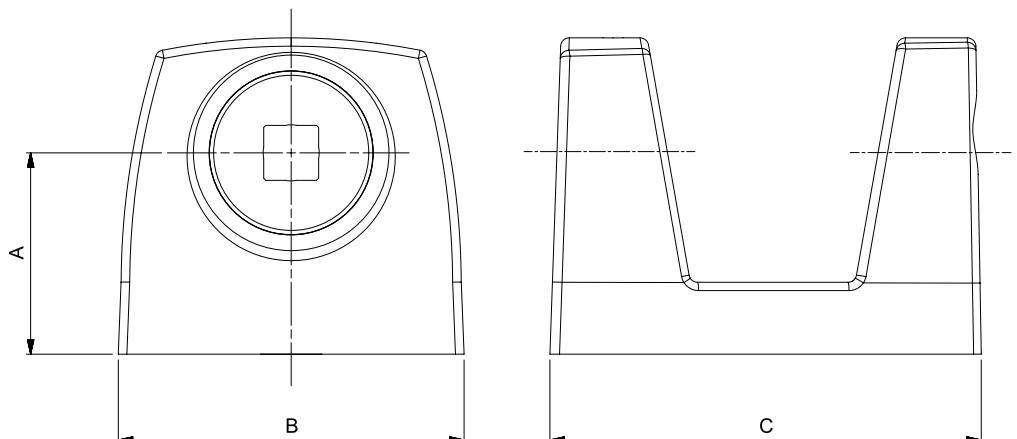



STATIC TRANSDUCERS



Calibration details



The accuracy and quality of the Norbar Static Torque Transducers has made them the first choice of many calibration laboratories throughout the world. Up to 5,000 N·m (5,000 lbf·ft) classified to BS7882:2017, typically better than Class 1 for the primary classification range ($\pm 0.5\%$ of reading from 20% to 100% of full scale).

- Robust, heat treated, alloy steel torsion shaft design
- Designed to ignore non-torsional forces
- Operates in clockwise and counter-clockwise directions
- Calibration up to 100,000 N·m with a UKAS accredited certificate
- Calibrated in clockwise direction as standard. Counter-clockwise provided on request

- Smart transducers have a built in memory circuit which contains essential information about the transducer. This information can be read by Norbar's TST, TTT, TTL-HE & T-Box™ 2 instruments meaning that when the transducer is connected, it is immediately recognised and ready for use
- Smart transducers can also be used with many other instruments, however these will operate as normal ratio calibrated (mV/V) transducers - the smart data will not be read

Static Transducers ¼" through to 1"

4	STATIC TRANSDUCERS - 0.1 - 1,500 N·m	
50587.xxx*	0.1 - 1 N·m	¼" M/F
50588.xxx	0.25 - 2.5 N·m	¼" M/F
50589.xxx	0.5 - 5 N·m	¼" M/F
50590.xxx	1 - 10 N·m	¼" M/F
50591.xxx	2.5 - 25 N·m	⅜" M/F
50592.xxx	5 - 50 N·m	⅜" M/F
50593.xxx	10 - 100 N·m	½" M/F
50594.xxx	25 - 250 N·m	½" M/F
50701.xxx	25 - 250 N·m	¾" M/F
50849.xxx	35 - 350 N·m	½" M/F
50596.xxx	50 - 500 N·m	¾" M/F
50772.xxx	100 - 1,000 N·m	1" M/F
50766.xxx	150 - 1,500 N·m	1" M/F

4	STATIC TRANSDUCERS - 0.1 - 1,000 lbf·ft	
50611.xxx	0.1 - 1 lbf·ft	¼" M/F
50615.xxx	0.5 - 5 lbf·ft	¼" M/F
50618.xxx	1 - 10 lbf·ft	¼" M/F
50620.xxx	2.5 - 25 lbf·ft	⅜" M/F
50836.xxx	5 - 50 lbf·ft	½" M/F
50624.xxx	10 - 100 lbf·ft	½" M/F
50625.xxx	25 - 250 lbf·ft	½" M/F
50702.xxx	25 - 250 lbf·ft	¾" M/F
50627.xxx	50 - 500 lbf·ft	¾" M/F
50773.xxx	100 - 1,000 lbf·ft	1" M/F

4	STATIC TRANSDUCERS - 1 - 1,000 lbf·in	
50610.xxx*	1 - 10 lbf·in	¼" M/F
50612.xxx	2.5 - 25 lbf·in	¼" M/F
50614.xxx	5 - 50 lbf·in	¼" M/F
50617.xxx	10 - 100 lbf·in	¼" M/F
50619.xxx	25 - 250 lbf·in	⅜" M/F
50621.xxx	50 - 500 lbf·in	⅜" M/F
50623.xxx	100 - 1,000 lbf·in	½" M/F

4	STATIC TRANSDUCERS - 10 - 100 ozf·in	
50609.xxx*	10 - 100 ozf·in	¼" M/F

TD2.CCW Alternative calibration direction for transducers up to 1,500 N·m / 1,000 lbf·ft when ordered with new unit

xxx Indicates .LOG or .IND versions, please see page 98.
* .LOG versions not suitable for use with TST, TTT or TTL-HE, purchased pre Feb 2016.



Model	¼" M/F	⅜" M/F	½" M/F	¾" M/F	1" M/F	
Part Number	50587.xxx 50588.xxx 50589.xxx 50590.xxx 50611.xxx 50615.xxx 50618.xxx 50610.xxx 50612.xxx 50614.xxx 50617.xxx 50609.xxx	50591.xxx 50592.xxx 50620.xxx 50619.xxx 50621.xxx	50593.xxx 50594.xxx 50849.xxx 50836.xxx 50624.xxx 50625.xxx 50623.xxx	50701.xxx 50596.xxx 50702.xxx 50627.xxx	50772.xxx 50766.xxx 50773.xxx	
Dimensions (mm)	ØA	36	36	36	54	54
	B	33	33	33	42	42
	C	86	90	93	142	147
	D	10	13	16	24	29
	E	30	34	37	46	51
	F	6.5	10	13	22	26
Weight (kg)	0.6	0.6	0.6	1.5	1.7	

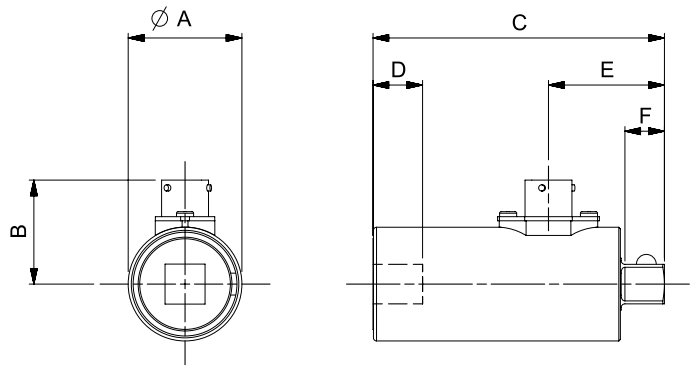



STATIC TRANSDUCERS

Calibration details



Static Transducers 1½" through to 3½" Male to Female (M/F)

4	STATIC TRANSDUCERS - 250 - 7,000 N·m	
50703.xxx	250 - 2,500 N·m	1½" M/F
50791.xxx	300 - 3,000 N·m	1½" M/F
50599.xxx	500 - 5,000 N·m	1½" M/F
50669.xxx@	700 - 7,000 N·m	1½" M/F

4	STATIC TRANSDUCERS - 250 - 5,000 lbf·ft	
50704.xxx	250 - 2,500 lbf·ft	1½" M/F
50630.xxx	500 - 5,000 lbf·ft	1½" M/F

TD5.CCW@ Alternative calibration direction for transducers from 1,501 - 7,000 N·m / 1,001 - 5,000 lbf·ft when ordered with new unit

4	STATIC TRANSDUCERS - 1,000 - 100,000 N·m	
50776.xxx	1,000 - 10,000 N·m	2½" M/F
50797.xxx	2,500 - 25,000 N·m	2½" M/F
50781.xxx	5,000 - 50,000 N·m	2½" M/F
50783.xxx	8,000 - 80,000 N·m	3½" M/F
50816.xxx	10,000 - 100,000 N·m	3½" M/F

4	STATIC TRANSDUCERS - 1,000 - 60,000 lbf·ft	
50777.xxx	1,000 - 10,000 lbf·ft	2½" M/F
50798.xxx	2,500 - 25,000 lbf·ft	2½" M/F
50799.xxx	3,000 - 30,000 lbf·ft	2½" M/F
50782.xxx	6,000 - 60,000 lbf·ft	3½" M/F

TD3.CCW+ Alternative calibration direction for transducers from 7,001 - 100,000 N·m / 5,001 - 100,000 lbf·ft when ordered with new unit

- xxx Indicates .LOG or .IND versions, please see page 98.
- * .LOG versions not suitable for use with TST, TTT or TTL-HE, purchased pre Feb 2016.
- @ UKAS accredited calibration up to 6,000 N·m. A non-accredited value at 7,000 N·m is extrapolated and provided for reference only.
- + UKAS accredited calibration up to 80,000 lbf·ft. A non-accredited value at 100,000 lbf·ft is extrapolated and provided for reference only.



Model	1½" M/F	2½" M/F	3½" M/F	
Part Number	50703.xxx 50791.xxx 50599.xxx 50669.xxx 50704.xxx 50630.xxx	50776.xxx 50797.xxx 50781.xxx 50777.xxx 50798.xxx 50799.xxx	50783.xxx 50816.xxx 50782.xxx	
Dimensions (mm)	ØA	95	130	160
	B	59	80	107
	C	160	209	292
	D	41	59	91
	E	85	114	147
	F	38	57	76
Weight (kg)	4.5	11.5	16.5	

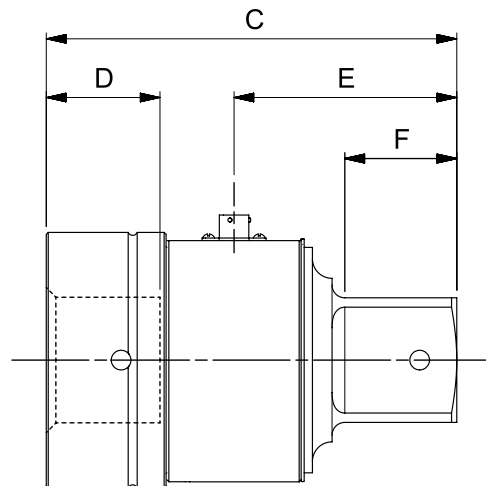
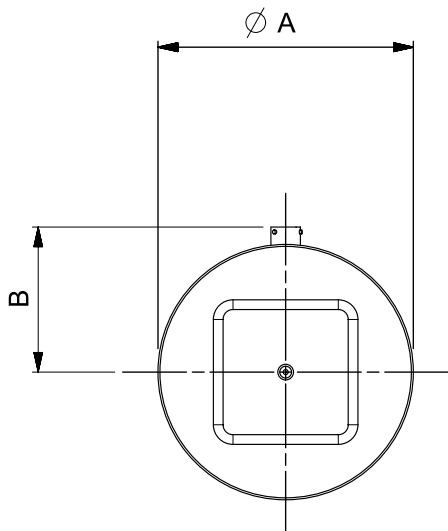



STATIC TRANSDUCERS

Calibration details



Static Transducers 2½" through to 3½" Male to Male (M/M)

4	STATIC TRANSDUCERS - 2,500 - 100,000 N·m	
50603.xxx	2,500 - 25,000 N·m	2½" M/M
50794.xxx	5,000 - 50,000 N·m	3½" M/M
50796.xxx	10,000 - 100,000 N·m	3½" M/M

4	STATIC TRANSDUCERS - 2,500 - 100,000 lbf-ft	
50635.xxx	2,500 - 25,000 lbf-ft	2½" M/M
50795.xxx	5,000 - 50,000 lbf-ft	3½" M/M
50637.xxx+	10,000 - 100,000 lbf-ft	3½" M/M

TD3.CCW+ Alternative calibration direction for transducers from 7,001 - 100,000 N·m / 5,001 - 100,000 lbf-ft when ordered with new unit

4	STATIC TRANSDUCERS - 15,000 - 200,000 N·m	
-	15,000 - 150,000 N·m	4½" M/M
-	20,000 - 200,000 N·m	4½" M/M

- xxx Indicates .LOG or .IND versions, please see page 98.
- * .LOG versions not suitable for use with TST, TTT or TTL-HE, purchased pre Feb 2016.
- @ UKAS accredited calibration up to 6,000 N·m. A non-accredited value at 7,000 N·m is extrapolated and provided for reference only.
- + UKAS accredited calibration up to 80,000 lbf-ft. A non-accredited value at 100,000 lbf-ft is extrapolated and provided for reference only.



Model	2½" M/M	3½" M/M	
Part Number	50603.xxx 50635.xxx	50794.xxx 50796.xxx 50795.xxx 50637.xxx	
Dimensions (mm)	∅A	110	165
	B	82	95
	C	200	271
	D	57	76
	E	100	135
	F	57	76
Weight (kg)	11.5	16.5	

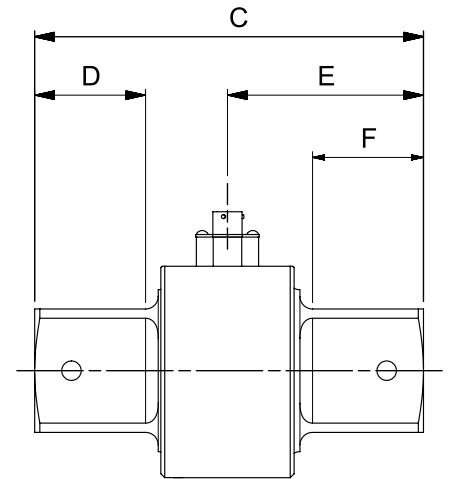
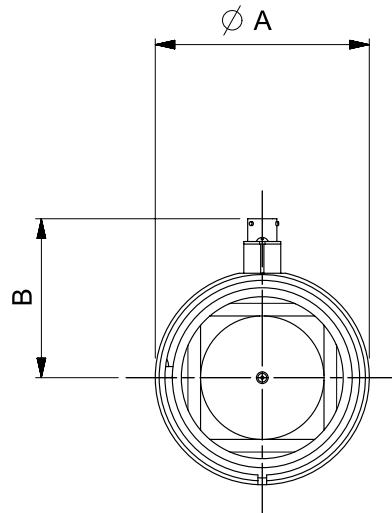

4	STATIC TRANSDUCERS
SECCAL.CW	Secondary calibration in one direction on static transducers with 2½" square drives to extend the range below 10% of the rated capacity, when ordered with new unit
SECCAL.CW+CCW	Secondary calibration in two directions on static transducers with 2½" square drives to extend the range below 10% of the rated capacity, when ordered with new unit
ADDCALPOINTS.NEW	Additional calibration steps below 10% of rated capacity to 2% for transducers up to 7,000 N·m (5,000 lbf-ft) when ordered with new unit



ROTARY TRANSDUCERS



Rotary transducers are designed to measure the torque from continuously rotating shafts such as impulse power tools and certain non-impulse tools with a severe clutch action.

This range offers class-leading performance with impulse tools and will be supplied with a UKAS accredited calibration certificate from Norbar's laboratory.

These transducers are known as Smart transducers. They have built-in intelligence in the form of a memory circuit which contains essential information about the transducer which can be read by the appropriate type of instrument (TST, TTT, TTL-HE & T-Box™ 2), thus reducing set-up time.

They will also work with instruments that cannot read the memory information, by inputting the relevant calibration details manually.

Note: Not for use with Impact Tools.

Angle measurement also available.



4	ROTARY TRANSDUCERS
50708.xxx	0.25 - 5 N·m ¼" M/F Hex
50709.xxx	1 - 20 N·m ¼" M/F Hex
50710.xxx	1 - 20 N·m ¼" M/F sq. dr.
50719.xxx	0.75 - 15 lbf·ft ¼" M/F sq. dr.
50711.xxx	3.75 - 75 N·m ⅜" M/F sq. dr.
50720.xxx	2.5 - 50 lbf·ft ⅜" M/F sq. dr.
50712.xxx	10 - 200 N·m ½" M/F sq. dr.
50721.xxx	7.5 - 150 lbf·ft ½" M/F sq. dr.

4	ROTARY TRANSDUCERS
50713.xxx	12.5 - 250 N·m ¾" M/F sq. dr.
50722.xxx	10 - 200 lbf·ft ¾" M/F sq. dr.
50714.xxx	25 - 500 N·m ¾" M/F sq. dr.
50723.xxx	15 - 300 lbf·ft ¾" M/F sq. dr.
50715.xxx	75 - 1,500 N·m 1" M/F sq. dr.
50724.xxx	50 - 1,000 lbf·ft 1" M/F sq. dr.
TD2.CCW	Counter-clockwise calibration

Angle options available, contact Norbar.

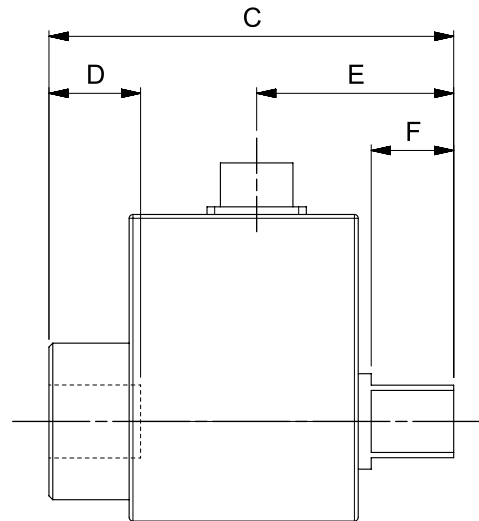
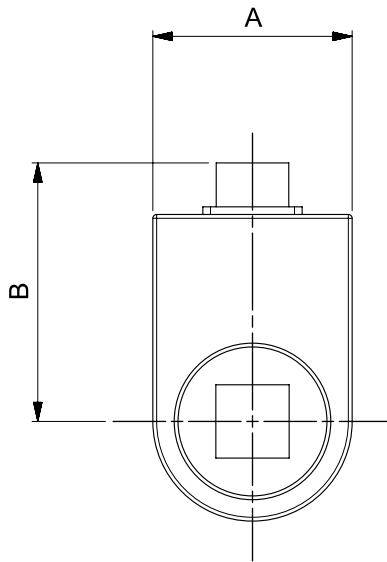

Model	¼" M/F Hex	¼" M/F sq. dr.	⅜" M/F sq. dr.	½" M/F sq. dr.	¾" M/F sq. dr.	1" M/F sq. dr.
Part Number	50708.xxx 50709.xxx	50710.xxx 50719.xxx	50711.xxx 50720.xxx	50712.xxx 50721.xxx	50713.xxx 50714.xxx 50722.xxx 50723.xxx	50715.xxx 50724.xxx
Dimensions (mm)	A	30	30	30	42	52
	B	58	58	62	67	73
	C	116	72	77	87	106
	D	N/A	10	13	16	24
	E	49	33	36	42	51
	F	26	7	11	15	21
Weight (kg)	0.2	0.2	0.2	0.4	0.8	1.5



FLANGE MOUNTED TRANSDUCERS (FMT)



Calibration details



FMT 2 N-m

4	FMT
50671.xxx*	0.04 - 2 N-m, 1/4" sq. dr. with Joint Simulator
50672.xxx	0.5 - 10 N-m, 1/4" sq. dr. with Joint Simulator
50673.xxx	1.25 - 25 N-m, 1/4" + 3/8" sq. dr. with Joint Simulator
50677.xxx*	0.4 - 20 lbf-in, 1/4" sq. dr. with Joint Simulator
50678.xxx	5 - 100 lbf-in, 1/4" sq. dr. with Joint Simulator
50679.xxx	12.5 - 250 lbf-in, 1/4" + 3/8" sq. dr. with Joint Simulator

Flange Mounted Transducers (FMT) incorporate mounting points for securely fixing the transducer to the working surface. The transducer lead which comes attached to the transducer, is fitted with a high quality connector, suitable for attachment to TST, TTT and T-Box™ 2 instruments. FMTs are provided with precision square drive adaptors suitable for the calibration of torque wrenches.



FMT 1,500 N-m

4	FMT
50676.xxx	30 - 1,500 N-m, 1/2", 3/4" + 1" sq. dr.
50682.xxx	20 - 1,000 lbf-ft, 1/2", 3/4" + 1" sq. dr.
TD1.CCW	Counter-clockwise calibration for FMT & STB when ordered with new unit



FMT 150 N-m

4	FMT
50844.xxx	3 - 60 N-m, 1/2" + 3/8" sq. dr. with Joint Simulator
50674.xxx	7.5 - 150 N-m, 1/2" + 3/8" sq. dr. with Joint Simulator
50680.xxx	5 - 100 lbf-ft, 1/2" + 3/8" sq. dr. with Joint Simulator
50675.xxx	20 - 400 N-m, 1/2" + 3/4" sq. dr.
50681.xxx	12.5 - 250 lbf-ft, 1/2" + 3/4" sq. dr.



xxx Indicates .LOG or .IND versions, please see page 98.

* If using this transducer with a Series 1 TST or TTT (Part No.s 43198 - 43201) or a Pro-Log Display instrument, please contact Norbar.

Includes integral transducer lead with connector to suit TST, TTT and T-Box™ 2. Additional lengths can be accommodated, consult Norbar for details.



FLANGE MOUNTED TRANSDUCERS (FMT)

Calibration details



Model	FMT (2 N·m - 25 N·m)	FMT (60 N·m - 400 N·m)	FMT (1,500 N·m)	
Part Number	50671.xxx 50672.xxx 50673.xxx 50677.xxx 50678.xxx 50679.xxx	50844.xxx 50674.xxx 50680.xxx 50675.xxx 50681.xxx	50676.xxx 50682.xxx	
Dimensions (mm)	ØA	5.5	8.5	12
	ØB	64	90	150
	C	63	65	84
	D	83 (1/4"), 86 (3/8")	92 (3/4"), 95 (3/8"), 101 (1/2")	128 (1/2"), 138 (3/4"), 138 (1")
	E	132	192 (60 N·m, 150 N·m & 100 lbf-ft) N/A (400 N·m & 250 lbf-ft)	N/A
Weight (kg)	0.8 (2 N·m & 20 lbf-in) 0.8 (10 N·m & 100 lbf-in) 0.9 (25 N·m & 250 lbf-in)	3.3 (60 N·m, 150 N·m & 100 lbf-ft) 1.5 (400 N·m) 2.7 (250 lbf-ft)	7.0	

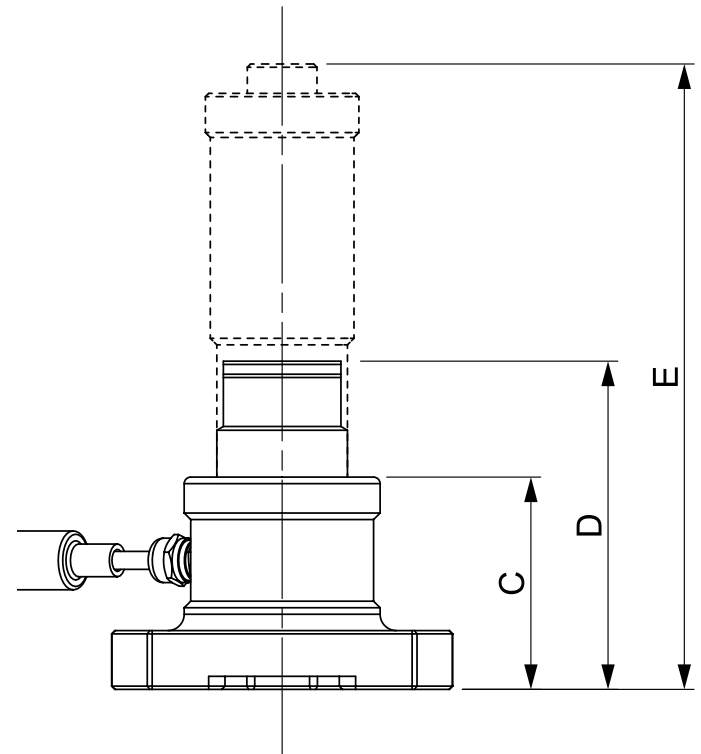
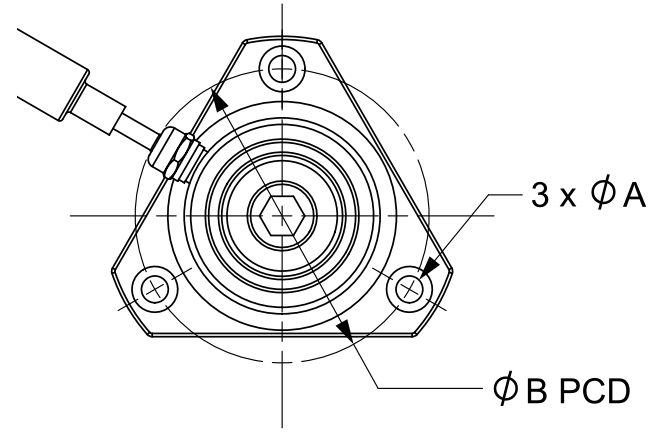

FMT 400 N·m
shown with case

4	FMT (Ancillary Section)
50539	2 N·m Joint Simulator (also fits TST)
50540	10 N·m Joint Simulator (also fits TST)
50541	25 N·m Joint Simulator (also fits TST)
50845	60 N·m Joint Simulator
50692	150 N·m Joint Simulator
50819	400 N·m Joint Simulator
52236	1/4" Hexagon - 1/4" Square Drive Adaptor
52237	1/4" Hexagon - 3/8" Square Drive Adaptor
52251	3/8" Female Square - 22 mm Bi-Square Adaptor
52246	1/2" Female Square - 22 mm Bi-Square Adaptor
52245	3/4" Female Square - 22 mm Bi-Square Adaptor
52254	1/2" Female Square - 35 mm Bi-Square Adaptor
52241	3/4" Female Square - 35 mm Bi-Square Adaptor
52242	1" Female Square - 35 mm Bi-Square Adaptor



FMT Mounting Brackets

4	FMT Mounting Brackets
62221.BLK9005	FMT Mounting Bracket 2 - 400 N·m
62220.BLK9005	FMT Mounting Bracket 150 - 1,500 N·m



ANNULAR TRANSDUCERS



Calibration details



These Annular Transducers are designed to fit directly to Norbar torque multipliers and will accurately measure the torque output from the gearbox, via a display instrument (instrument supplied separately, see pages 93 - 94 & 96).

- Up to 6,000 N·m classified to BS7882:2017, typically better than Class 1 for the primary classification range ($\pm 0.5\%$ of reading from 20% to 100% of full scale)
- Robust heat treated alloy steel torsion tube design
- Designed to ignore non-torsional forces
- Smart transducers have a built in memory circuit which contains essential information about the transducer. This information can be read by Norbar's TST, TTT, TTL-HE & T-Box™ 2 instruments meaning that when the transducer is connected, it is immediately recognised and ready for use
- Smart transducers can also be used with many other instruments, however, these will operate as normal ratio calibrated (mV/V) transducers - the Smart data will not be read



4 ANNULAR TRANSDUCERS FOR STANDARD SERIES GEARBOX	
Suitable for PT1, PT1A and PT2	
50638.xxx	100 - 1,000 N·m ¾" sq. dr.
50648.xxx	100 - 1,000 lbf-ft ¾" sq. dr.
Suitable for heavy duty HT2, PT1, PT1A and PT2	
50639.xxx	150 - 1,500 N·m 1" sq. dr.
50649.xxx	150 - 1,500 lbf-ft 1" sq. dr.
TD2.CCW	Alternative calibration direction for transducers up to 1,500 N·m / 1,000 lbf-ft when ordered with new unit
Suitable for HT5 and PT5	
50640.xxx	250 - 2,500 N·m 1" sq. dr.
50650.xxx	250 - 2,500 lbf-ft 1" sq. dr.
50641.xxx	350 - 3,500 N·m 1" sq. dr.
Suitable for HT6 and PT6	
50700.xxx	350 - 3,500 N·m 1½" sq. dr.
Suitable for HT7 and PT7	
50643.xxx	500 - 5,000 N·m 1½" sq. dr.
50652.xxx	500 - 5,000 lbf-ft 1½" sq. dr.
TD5.CCW@	Alternative calibration direction for transducers from 1,501 - 7,000 N·m / 1,001 - 5,000 lbf-ft when ordered with new unit

4 ANNULAR TRANSDUCERS FOR STANDARD SERIES GEARBOX	
Suitable for HT9 and PT9	
50644.xxx	1,000 - 10,000 N·m 1½" sq. dr.
50653.xxx	700 - 7,000 lbf-ft 1½" sq. dr.
Suitable for HT11 and PT11	
50645.xxx	2,000 - 20,000 N·m 2½" sq. dr.
50654.xxx	1,500 - 15,000 lbf-ft 2½" sq. dr.
Suitable for HT12 and PT12	
50764.xxx	3,500 - 35,000 N·m 2½" sq. dr.
50765.xxx	2,500 - 25,000 lbf-ft 2½" sq. dr.
Suitable for HT13 and PT13	
50646.xxx	5,000 - 50,000 N·m 2½" sq. dr.
Suitable for PT14	
50647.xxx	10,000 - 100,000 N·m 3½" sq. dr.
TD4.CCW	Alternative calibration direction for transducers from 7,001 - 100,000 N·m / 5,001 - 75,000 lbf-ft when ordered with new unit
Suitable for PT18.MTS	
-	30,000 - 300,000 N·m

Standard calibration is performed loading counter-clockwise only.

@ UKAS accredited calibration up to 6,000 N·m. A non-accredited value at 7,000 N·m is extrapolated and provided for reference only.

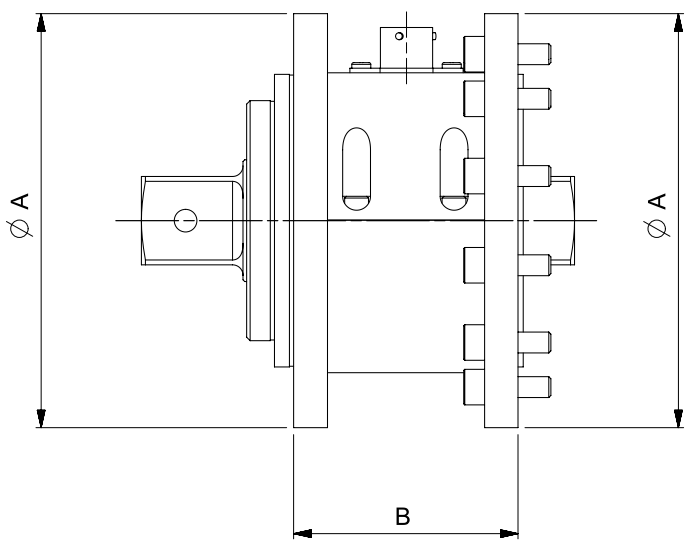

PT 18 fitted with 300,000 N·m Annular Transducer and square drive

Model	Annular Transducers for use with Standard Series Multipliers		
Part Number	50638.xxx 50648.xxx 50639.xxx 50649.xxx	50640.xxx 50650.xxx 50641.xxx 50700.xxx	50643.xxx 50652.xxx
Dimensions (mm)	ØA	108	119
	B	60	65
Weight (kg)	1.4	2.6	3.6



ANNULAR TRANSDUCERS

Calibration details



4 TORQUE & ANGLE ANNULAR TRANSDUCERS - FIXED CONNECTOR

Suitable for heavy duty PT1, PT1A and PT2

50820.LOGA* 100 - 1,000 N·m ¾" sq. dr.

50821.LOGA** 150 - 1,500 N·m 1" sq. dr.

* Can only be used with remote/plain sleeve motors i.e. not a standard PT handle, due to cable interference.

** Only fits to PT with HD final stage carrier having 1" female sq. dr.

Suitable for HT5 and PT5

50822.LOGA 350 - 3,500 N·m 1" sq. dr.

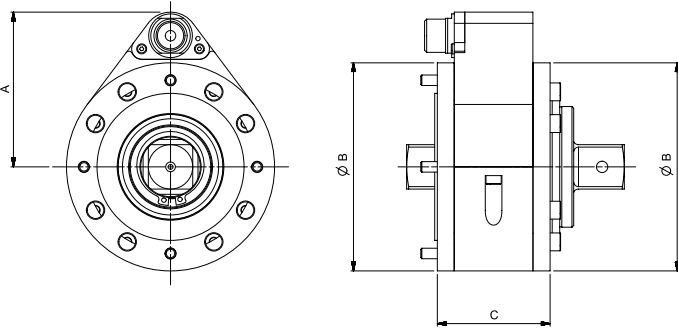

Model	Torque & Angle Annular Transducers with Fixed Connector	
Part Number	50820.LOGA 50821.LOGA 50822.LOGA	
Dimensions (mm)	A	89
	ØB	119
	C	65
Weight (kg)	1.4	



Fixed Connector

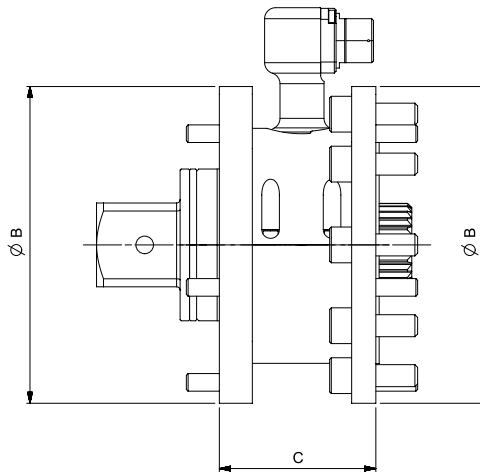
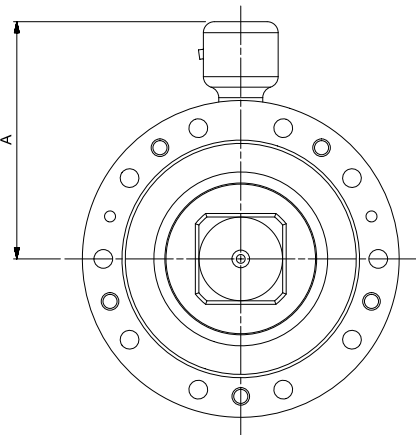

180° Swivel Connector

4 TORQUE & ANGLE ANNULAR TRANSDUCERS - 180° SWIVEL CONNECTOR

Suitable for HT7 and PT7

50834.LOGA 500 - 5,000 N·m 1½" sq. dr.

Suitable for HT9 and PT9

50824.LOGA 1,000 - 10,000 N·m 1½" sq. dr.

Suitable for HT11 and PT11

50825.LOGA 2,000 - 20,000 N·m 2½" sq. dr.

Suitable for HT12 and PT12

50826.LOGA 3,500 - 35,000 N·m 2½" sq. dr.

Suitable for HT13 and PT13

50827.LOGA 5,000 - 50,000 N·m 2½" sq. dr.

Suitable for HT14 and PT14

50828.LOGA 10,000 - 100,000 N·m 3½" sq. dr.

PT13 & PT14 require special front cover plate with added dowel clearance holes

Suitable for HT15 and PT15

50832.LOGA 15,000 - 150,000 N·m 4½" sq. dr.

Suitable for HT16 and PT16

50829.LOGA 20,000 - 200,000 N·m 5" sq. dr.

Suitable for HT17 and PT17

50830.LOGA 25,000 - 250,000 N·m 6" sq. dr.

Suitable for HT18 and PT18

50831.LOGA 30,000 - 300,000 N·m 6" sq. dr.

Model	Torque & Angle Annular Transducers with Swivel Connector										
	5,000 N·m	10,000 N·m	20,000 N·m	35,000 N·m	50,000 N·m	100,000 N·m	150,000 N·m	200,000 N·m	250,000 N·m	300,000 N·m	
Part Number	50834.LOGA	50824.LOGA	50825.LOGA	50826.LOGA	50827.LOGA	50828.LOGA	50832.LOGA	50829.LOGA	50830.LOGA	50831.LOGA	
Dimensions (mm)	A	108	120	140	151	186	186	*	*	*	289
	ØB	144	178	212	248	315	315	*	*	*	520
	C	144	184	212	240	315	315	*	*	*	520
Weight (kg)	7.0	10.0	15.0	29.3	43.5	46.6	*	*	*	149.5	

* Available on request



ANNULAR TRANSDUCERS



4 ANNULAR TRANSDUCERS FOR 72 mm SERIES GEARBOX (HT & PT) (Not suitable for PTS/PTM tools)

Suitable for PT-72 mm Remote Series and HT-72	
50666.xxx	100 - 1,000 N·m
50667.xxx	150 - 1,500 N·m
50668.xxx	200 - 2,000 N·m

Standard calibration is performed loading counter-clockwise only.

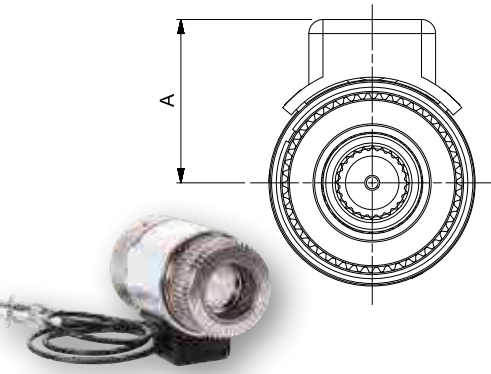

Torque and Angle Annular Transducer Note:

- 5,000 N·m and above include dowels on both mounting faces
- Angle resolution < 1° when used with T-Box™ 2
- CW+CCW calibration is standard
- Use 60308.xxx series lead for direct connection to T-Box™ 2 for torque and angle/turns monitoring and storage
- PT square drive and other parts may require removal to fit transducer
- All the above are standard construction. Harsh Environment models are available on request
- '.INDA' versions are available on request

Note: PTS™ and reactions with dowel holes can be supplied at an extra cost on request. Request details on PneuTorque® Type '.XD'

4 ANNULAR TRANSDUCERS FOR PTS/PTM 72

Suitable for PTS/PTM-72 mm Series	
50840.xxx	100 - 1,000 N·m
50841.xxx	150 - 1,500 N·m
50842.xxx	200 - 2,000 N·m
50846.LOGA	100 - 1,000 N·m with Angle

Model	Annular Transducers for use with 72 mm Series Multipliers	Annular Transducers for use with 72 mm Series Multipliers
Part Number	50666.xxx 50667.xxx 50668.xxx 50840.xxx 50841.xxx 50842.xxx	50846.LOGA
Dimensions (mm)	A	85
	B	93
	∅C	73
Weight (kg)	1.5	3.1

4 ANNULAR TRANSDUCERS

SECCAL.CW	Secondary calibration in one direction on annular transducers for HT/PT9 & HT/PT11 to extend the range below 10% of the rated capacity, when ordered with new unit
SECCAL.CW+CCW	Secondary calibration in two directions on annular transducers for HT/PT9 & HT/PT11 to extend the range below 10% of the rated capacity, when ordered with new unit
ADDCALPOINTS.NEW	Additional calibration steps below 10% of rated capacity to 2% for transducers up to 7,000 N·m (5,000 lbf·ft) when ordered with new unit

TRANSDUCER LEADS



If ordering a static, annular or rotary transducer you will also require a corresponding lead (see list below). To comply with the latest calibration standards, most new transducer leads will have a suffix to indicate the length in centimetres.

4 TRANSDUCER LEADS

60216.200	PRO-LOG, TST, TTT, T-Box XL & T-Box 2 to 10 Way Transducer for use with Norbar Rotary Transducers
60217.200	PRO-LOG, TST, TTT, T-Box XL & T-Box 2 to 6 Way Transducer for use with Norbar Static & Annular Transducers
60223.200	PRO-LOG, TST, TTT, T-Box XL & T-Box 2 to no connector
60224.200	10 Way Transducer to no connector
60225.200	6 Way Transducer to no connector
51067.225	ETS to Transducer (Pre 1994) + 5 way (60055)
60152.225	ETS to Transducer (Post 1994) + 5 way (60163)
60308.400	PRO-LOG, TST, TTT, T-Box XL & T-Box 2 to Torque & Angle Annular Transducers

4 TRANSDUCER LEADS

60308.600	PRO-LOG, TST, TTT, T-Box XL & T-Box 2 to Torque & Angle Annular Transducers
60308.1000	PRO-LOG, TST & TTT to Torque & Angle Annular Transducers

Other lengths can be ordered at an additional cost.
 Note: The system should be calibrated with the increased length lead, as calibration may be affected.
 Note: The maximum permissible cable length is 15 m for TST, TTT or T-Box™ 2 and 7 m with a T-Box™ XL. Contact Norbar for further details.



ISO 3000 LOADER

These loaders allow torque wrenches to be tested or calibrated to relevant ISO standards when used in an appropriate temperature controlled environment. Their function is to take full advantage of the accuracy of Norbar’s torque measuring system by reducing operator induced variations in the calibration process.

- The high ratio, 1250:1 gearbox allows high torques to be applied with minimal effort
- Used with a T-Box™ 2 instrument, the timer feature will allow the rate of torque application to meet the requirement of ISO6789:2017
- The design allows for easy interchange of transducers using the Norbar Static Transducer system
- Floating reaction point minimises side loads on the wrench. It is a requirement of ISO6789:2017 that parasitic forces on the wrench under test are minimised
- Reaction extension bar allows wrenches up to 2,200 mm to be tested. This can be removed to save space. Wrenches up to 1,100 mm can be tested when the extension bar is not fitted



4 TORQUE WRENCH LOADERS	
20505	Loader, ISO 3,000 N-m
20506	Motorised ISO 3,000 N-m
20606	Short Length Reaction Plate Assembly

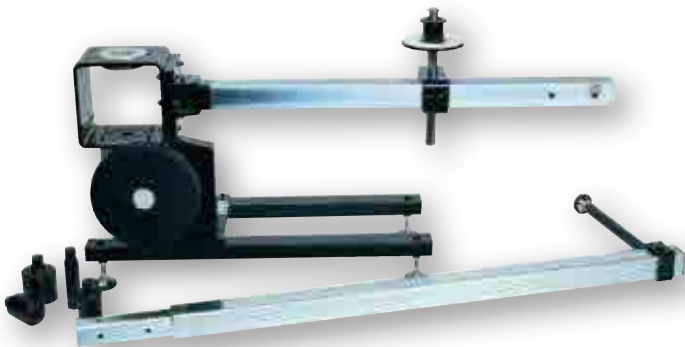

20505 ISO 3,000 N-m Loader

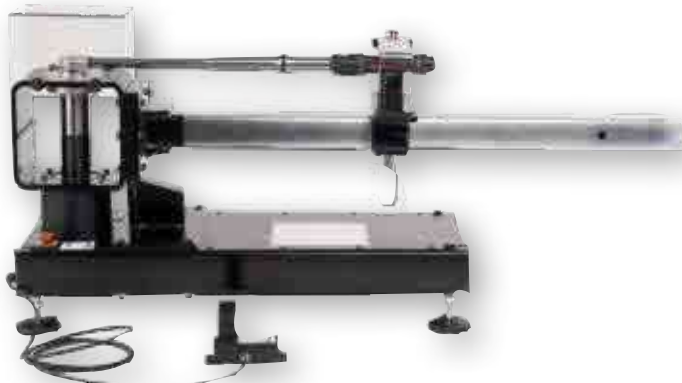

20506 ISO 3,000 N-m Motorised Loader

Model	ISO 3000 N-m	Motorised ISO 3000 N-m
Part Number	20505	20506
Dimensions (mm)	A	451
	B	2,440
	C	1,232
	D	534
Weight (kg)	55.0	40.0

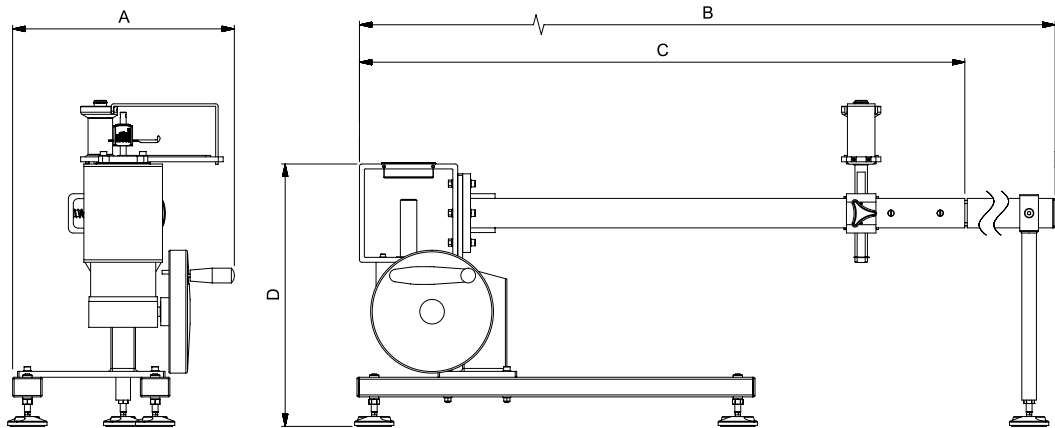



TORQUE WRENCH CALIBRATOR - MANUAL



Torque Wrench Calibrator (TWC) 400 N-m Manual

- Enables torque wrench calibration or testing in accordance with ISO 6789-2:2017 if used with T-Box™ 2
- Also in accordance with BS EN 26789:2003, ISO 6789-1:2017
- Counterbalance Reaction system is designed to support the weight of the wrench so that the weight does not become a parasitic force within the calibration system. The floating nature of the support means that the wrench is able to find its own natural level rather than being constrained as in many other loading devices. Any such constraint will be a parasitic force within the system (Patents apply)
- Lightweight alloy construction ensures the TWC is easily transported, making it well suited for mobile laboratory applications

- Two speed gearbox designed for a sufficient balance of speed and control by allowing for both fast loading of the torque wrench and a slower more precise loading
- Works with Flange Mounted Transducers, Static Transducers (when using part number: 60318), T-Box™ 2, TST, TTT and Pro-Test (when using part number: 60323)
- During calibration the TWC maintains a fixed position on the handle of the torque wrench
- Rotating transducer design ensures that the load is applied 90° to the torque wrench handle. The benefit of this precise alignment is that forces are applied squarely to the load point of the handle
- When testing for conformity or calibrating to ISO6789:2017 any transducer must not be used below 5% of its capacity when used with TWC. This statement does not apply to a TWC when used in a accredited laboratory

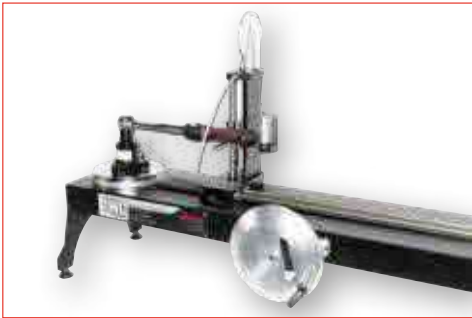

Torque Wrench Calibrator (TWC) Manual shown with a Flange Mounted Transducer and a Model 100 torque wrench (not included)

4	TORQUE WRENCH CALIBRATOR (TWC)
60331	Torque Wrench Calibrator 400 N-m Manual
60332	Torque Wrench Calibrator 1,500 N-m Manual

Model		TWC 400	TWC 1500
Part Number		60331	60332
Wrench Length (Torque Radius)	Min	135	135
	Max	750	1,500
Dimensions (mm)	A	620	620
	B	330	330
	C	395	395
	D	487	487
	E	1,010	1,760
Weight (kg)		35.0	40.0

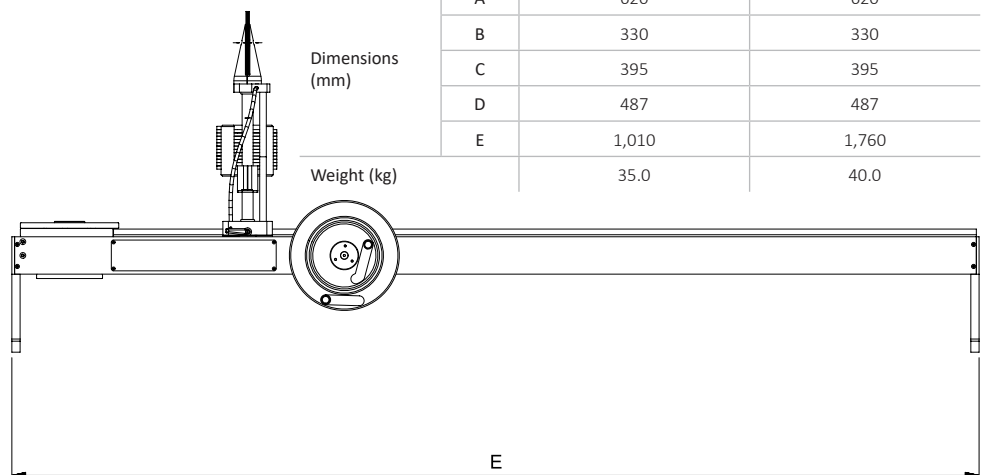
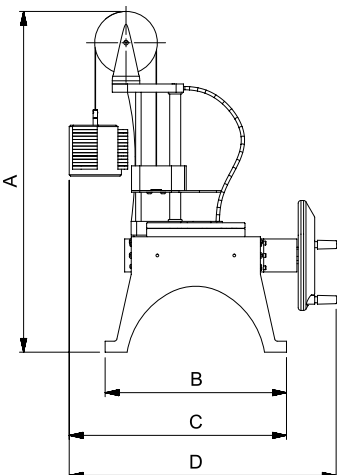

Patented in the UK, Germany, France and Italy (EP2864745) and in the USA (US9921122).



TORQUE WRENCH CALIBRATOR - ANCILLARIES

There are a wide range of accessories available for the TWC that will allow the user greater flexibility.

- 60322 Quick Release Kit allows for a more streamlined and efficient calibration laboratory
- 60324 Hexagon Adaptor Kit for use with the TWC Manual allows users to speed up the workflow by implementing their own solution to rapidly manoeuvre the wrench up to the reaction point
- 60330 Offset Angle Plate Kit allows for greater flexibility when calibrating fixed head torque wrenches

8	TWC ANCILLARIES
60318	Static Transducer Support Kit
60319	Short Length Reaction Post
60322*	Quick Release FMT Kit
60323	Pro-Test and Static Torque Block Adaptor Kit
60324	Hexagon Adaptor Kit
60325	TWC Greasing Kit
60327	FMT 2 to FMT 25 Adaptor Kit
60329	3 kg Mass Weight
60330	Offset Angle Plate Kit
29214	1" Male to 3/4" Female Flanged Square Drive Adaptor
29215	1" Male to 1/2" Female Flanged Square Drive Adaptor
29216	1" Male to 3/8" Female Flanged Square Drive Adaptor
29217	1" Male to 1/4" Female Flanged Square Drive Adaptor

* Kit contains two Quick Release FMT plates



60318 Static Transducer Support Kit and 60319 Short Length Reaction Post



60322 Quick Release FMT Kit



60330 Offset Angle Plate Kit



29214 Flanged Square Drive Adaptor



60323 Pro-Test and Static Torque Block Adaptor Kit



60324 Hexagon Adaptor Kit



60329 3 kg Mass Weight



TORQUE WRENCH CALIBRATOR - AUTO



Calibration
details



For a complete torque wrench calibration system, just add the transducer range appropriate for the wrenches you wish to calibrate and accessories from page 110.

- Enables torque wrench calibration or testing in accordance with ISO 6789:2017 Part 1 and 2
- Counterbalance Reaction system is designed to support the weight of the wrench so that the weight does not become a parasitic force within the calibration system. The floating nature of the support means that the wrench is able to find its own natural level rather than being constrained as in many other loading devices. Any such constraint will be a parasitic force within the system (Patents apply)
- Lightweight alloy construction ensures the TWC is easily transported, making it well suited for mobile laboratory applications
- Works with Flange Mounted Transducers and Static Transducers
- During calibration, the TWC maintains a fixed position on the handle of the torque wrench
- Rotating transducer design ensures that the load is applied 90° to the torque wrench handle. The benefit of this precise alignment is that forces are applied squarely to the load point of the handle
- Supplied with a powerful yet simple touchscreen User Interface (UI) (keyboard and mouse also supported if desired)
- Flexible tool template system; minimises number of templates required to cover a wide range of tools, aiding efficient use
- Programmable calibration workflow for each template, can be pre-set to ISO compliant flow for the given tool for a faster set-up or can also support bespoke workflows

- Calibration job management; book calibrations, track progress of previous bookings and resume them
- Automated management of calibration and conformance workflows for non-indicating tools
- Intelligent rate control system ensures fast cycling of tools while maintaining compliance with 2017 standards
- Environmental monitoring (humidity/temperature) to assist compliance with calibration standards
- Automated management of uncertainty data for ISO 6789-2:2017 calibrations, guiding the user through the process using dynamically generated instructions based on the current tool's ISO classification and workflow
- Inbuilt data analysis and certification generation seamlessly move from calibration/conformance procedure to certificate generation, no third-party software required
- A substantial amount of inbuilt storage allowing for several years' worth of calibration data through normal use
- The TWC control Box is supported by a UKAS accredited certificate of calibration, we remain one of the few manufacturers in the world that issue a UKAS accredited calibration certificate both for the instrument and for the torque transducer. In doing so, customers can swap combinations of instrument and transducer while retaining complete traceability
- When testing for conformity or calibrating to ISO6789:2017 any transducer must not be used below 5% of its capacity when used with TWC. This statement does not apply to a TWC when used in a accredited laboratory



5	TORQUE WRENCH CALIBRATOR (TWC)
60312	Torque Wrench Calibrator 400 N-m Auto
60313	Torque Wrench Calibrator 1,500 N-m Auto



Torque Wrench Calibrator (TWC) Auto shown with a Professional Model 200 and a Static Transducer with support kit (not included)



TORQUE WRENCH CALIBRATOR - AUTO

Calibration details



Software Screen Shots:



Main menu



Tool template editor



Calibration job booking / editor



Tool cycling and adjustment

Model	TWC Auto 400	TWC Auto 1500
Part Number	60312	60313
Wrench Length (Torque Radius)	Min	135
	Max	750
Dimensions (mm)	A	620
	B	330
	C	395
	D	1,019
Weight (kg)	40.0	45.0

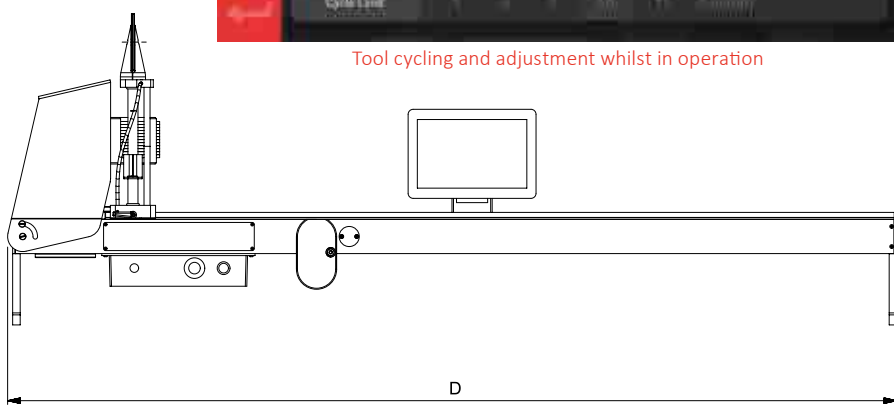
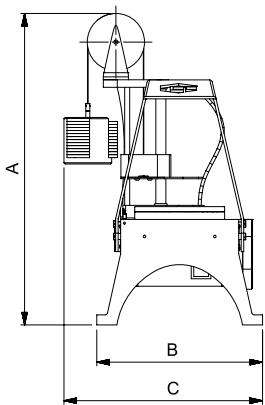

Tool cycling and adjustment whilst in operation

Patented in the UK, Germany, France and Italy (EP2864745) and in the USA (US9921122).



TEST RIGS AND FIXTURES



The Power Tool Test Fixture for TruCheck™ 2 is a simple, robust device that allows non-impacting power tools up to 2,100 N·m to be tested. A system comprises the Test Fixture with a TruCheck™ 2 Plus (to be ordered separately), either the 1,100 N·m or 2,100 N·m models, depending on the torque capacity required. The universal torque reaction arrangement will suit reaction arms supplied as standard with most Norbar and other pneumatic, electric and cordless torque tools.

NOTE: This Test Fixture is not suitable for TruCheck™ version 1.

4	POWER TOOL TEST FIXTURE FOR TRUCHECK 2
80033	Power Tool Test Fixture for use with TruCheck 2
4	80033 SPARE PARTS
81043	Spacer Sleeve
81044	Bellville Washer Stack (pack of 8 washers)
81045	Replacement Rundown Screw & Nut

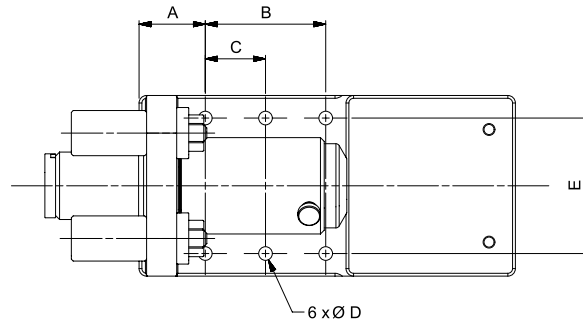

Model	Power Tool Test Fixture for TruCheck 2	
Part Number	80033	
Dimensions (mm)	A	56
	B	102
	C	51
	ØD	11.5
	E	114
	F	51
	G	152
	H	229
	J	75
	K	125
	L	77
M	86	
N	76	
P	6	
Q	318	
Weight (kg)	24.5	

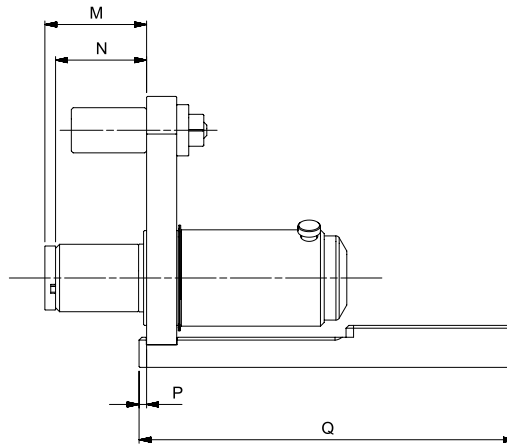
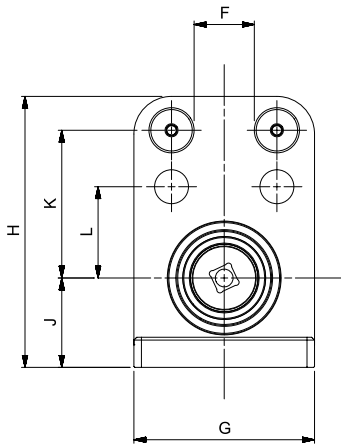

The Norbar Joint Simulation Rundown Assemblies are designed to simulate the working conditions of screwed or bolted joints. Used in conjunction with a Norbar transducer and display instrument, the output of torque controlled power tools can be measured against a range of simulated joint rates, from hard through to soft.

4	JOINT SIMULATION RUNDOWN ASSEMBLIES
50313	0.2 - 2 N·m (2 - 20 lbf·in)
50251	2 - 10 N·m (20 - 100 lbf·in)
50252	5 - 50 N·m (5 - 50 lbf·ft)
50253	10 - 100 N·m (10 - 100 lbf·ft)
50254*	100 - 500 N·m (100 - 500 lbf·ft)

The above are for use with Norbar static square to square transducers and bench stands, see page 98 & page 99.

* To be used with large frame size bench stands, all others to be used with small frame bench stands.

NOTE: Spare washer stacks are available for use with Joint Simulation Rundown Assemblies, contact Norbar

50693	10 - 140 N·m (10 - 100 lbf·ft)
50694	100 - 700 N·m (70 - 500 lbf·ft)

The above are for use with the Norbar Smart Torque Block (STB) 1000.



TEST RIGS AND FIXTURES

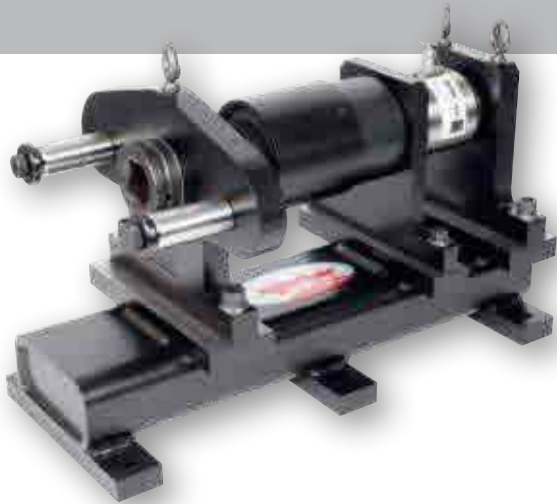

Power Tool Test Rig shown with 1½" M/F Static Transducer (not included)

4	ET/EBT/PT POWER TOOL TEST RIG
50800	7,000 N·m ET, EBT, PT Power Tool Test Rig (supplied with the 8 reaction plates on page 115 (excluding blank reaction plate) and ¾", 1" and 1½" sq. dr. adaptors)
50803	7,000 N·m ET, EBT, PT Power Tool Test Rig without Reaction Plates (supplied with ¾", 1" and 1½" sq. dr. adaptors)

Note: The static transducer 50669.LOG does not come supplied as standard with the tool test rig. The standard range of 700 - 7,000 N·m will not cover the full powered multiplier range, additional calibration may be required, please see below:

ADDCALPOINTS.NEW

Additional calibration steps below 10% of rated capacity to 2% for transducers up to 7,000 N·m (5,000 lbf·ft) when ordered with new unit

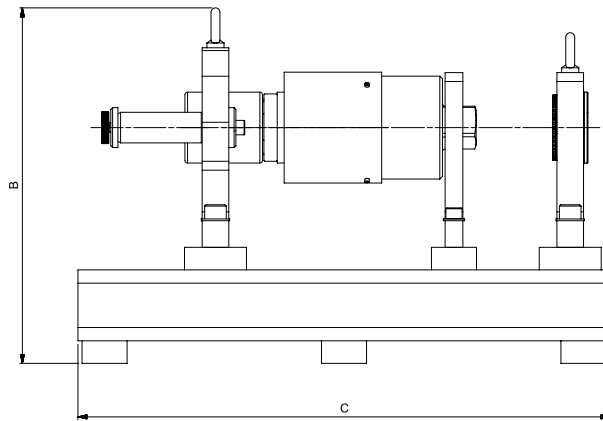
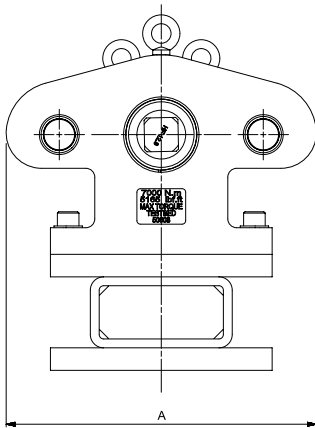

Model	Power Tool Test Rig	
Part Number	50800 50803	
Dimensions (mm)	A	350
	B	401
	C	600
Weight (kg)	TBC	



Universal Tool Test Rig (1½" M/F Static Transducer required (not included))

Model	Universal Tool Test Rig	
Part Number	50801, 50804	
Dimensions (mm)	A	180
	B	350
	C	415
	D	550
Weight (kg)	73.0	

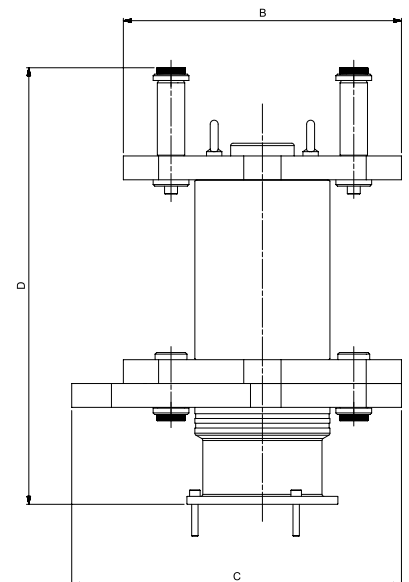
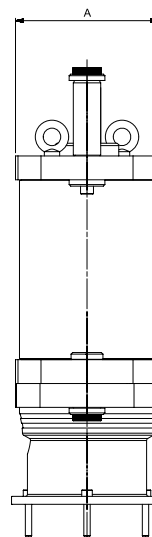

4	7,000 N·m UNIVERSAL TOOL TEST RIGS
50801	Universal 7,000 N·m ET, EBT, PT & Hydraulic Tool Test Rig (supplied with the 8 reaction plates on page 115 (excluding blank reaction plate) and ¾", 1" and 1½" sq. dr. adaptors)
50804	Universal 7,000 N·m Test Rig without Reaction Plates (supplied with ¾", 1" and 1½" sq. dr. adaptors)



TEST RIGS AND FIXTURES



Power Tool Test Rig with Reaction Plates (50800)



Universal Hydraulic Tool Test Rig with Reaction Plates (50801)



4 SPARES FOR 50800, 50801, 50803 & 50804

50800.29	2" AF Socket 1½" sq. dr.
50800.28	2" AF Socket 1" sq. dr.
50800.27	2" AF Socket ¾" sq. dr.



81041	Nut and bolt set for 7,000 N·m Power Tool Test Rigs
50548.4	Washer Stack Kit 100 - 7,000 N·m (Also for use with RD5000)

4 REACTION PLATES FOR USE WITH 50803 & 50804



81024	Suitable for ET/EBT/PTS/PTM 119, PT 4500 and PT 5500
-------	------------------------------------------------------



81025	Suitable for ET/EBT/PTS/PTM 92
-------	--------------------------------



81026	Suitable for ET/EBT/PTS/PTM 72
-------	--------------------------------



81027	Suitable for PTS/PTM 52
-------	-------------------------



81028	Suitable for PT 2700
-------	----------------------



81029	Suitable for PT 1, PT 1A and PT 2
-------	-----------------------------------



81030	Suitable for PT 5 and PT 6
-------	----------------------------



81031	Suitable for PT 7
-------	-------------------



81032	Blank Reaction Plate for Universal Test Rigs
-------	----------------------------------------------

NOTE: Reaction plate dimensions can be found by searching their part number on the Norbar website.

See page 117 & page 119 for accessories for use with Hydraulic Tool Calibration Fixture.



HYDRAULIC TOOL CALIBRATION FIXTURES

Norbar's Hydraulic Tool Calibration Fixture is a robust device that allows accurate testing of hydraulic torque wrenches. A system comprises of a Calibration Fixture and Transducer, also required is a torque measuring instrument and transducer cable.

- Bearing support for transducer gives improved accuracy
- Interchangeable stainless steel square and round reaction posts
- Hardened steel inserts to locate reaction posts in two positions: suits most hydraulic wrenches
- Optimised material sections for robust but portable design
- For hexagon link wrenches, a wide range of hexagon to square adaptors are available

Hydraulic Tool Calibration Fixtures	117
Hydraulic Tool Calibration accessories	118
Hexagon to Square Adaptors	119





HYDRAULIC TOOL CALIBRATION FIXTURES



4 CALIBRATION FIXTURES	
80031	Hydraulic Calibration Fixture up to 7,000 N-m
80029	Hydraulic Calibration Fixture up to 50,000 N-m
80032	Hydraulic Calibration Fixture up to 80,000 N-m
81022	Reaction Bar for 80031
81023	Reaction Bar for 80029

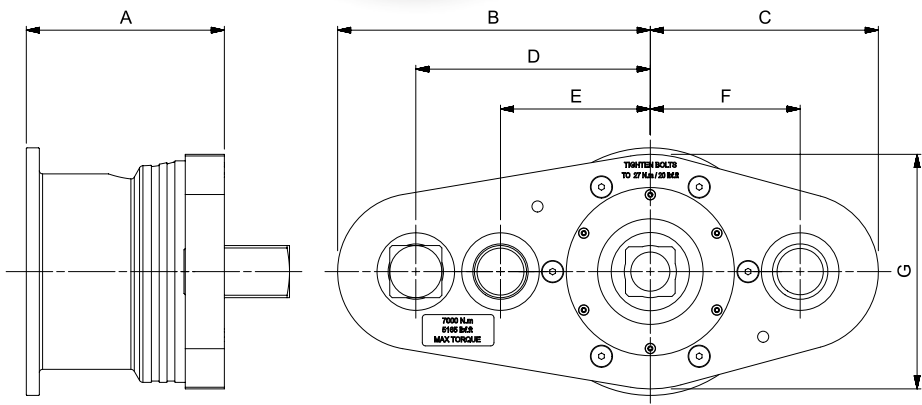

Model	Hydraulic Calibration Fixture up to 7,000 N-m	Hydraulic Calibration Fixture up to 50,000 N-m	Hydraulic Calibration Fixture up to 80,000 N-m	
Part Number	80031	80029	80032	
Dimensions (mm)	A	202	208	292
	B	240	325	450
	C	175	125	170
	D	180	150	260
	E	115	250	350
	F	115	N/A	N/A
	G	180	250	340
Weight (kg)	TBC	TBC	TBC	

4 DUAL CALIBRATION FIXTURE

80030 Dual Calibration Fixture
 Note: Houses 1 transducer up to 7,000 N-m and 1 transducer up to 50,000 N-m in a bench top plate.



Model	Dual Calibration Fixture	
Part Number	80030	
Dimensions (mm)	A	710
	B	193
	C	250
	D	142
	E	150
	F	380
	G	105
Weight (kg)	140.0	

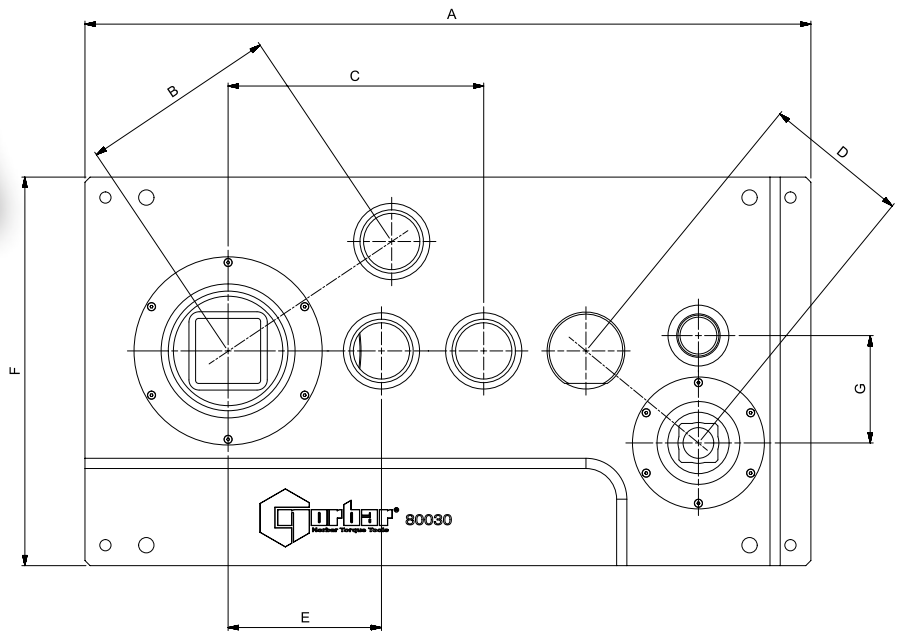

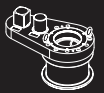

HYDRAULIC TOOL CALIBRATION ACCESSORIES



T-Box™ 2 at the centre of a test bench for hydraulic torque wrenches

Rapid hydraulic wrench calibrations (for instance, from many minutes to around one minute) are possible using appropriate hydraulic calibration fixtures and accessories along with the T-Box™ 2. The T-Box™ 2 can take simultaneous hydraulic pressure readings and torque readings at pre-configured trigger points. By ramping up the hydraulic pressure from the minimum to the maximum for the torque wrench under test, pressure and torque readings will be taken and recorded at the required points. This data can be saved to Excel and exported to appropriate third party calibration certification software.

This feature is not limited to hydraulic torque wrench calibration. By substituting the hydraulic pressure transducer for a pneumatic pressure transducer along with the appropriate calibration hardware, similar benefits of ease and speed can be applied to air tool calibration.

Contact technical@Norbar.com or your distributor for further details.



4	TRANSDUCERS FOR USE WITH 80031 / 80030
50703.xxx*	250 - 2,500 N·m, 1½" sq. dr. M/F
50704.xxx*	250 - 2,500 lbf-ft, 1½" sq. dr. M/F
50599.xxx*	500 - 5,000 N·m, 1½" sq. dr. M/F
50630.xxx*	500 - 5,000 lbf-ft, 1½" sq. dr. M/F
50669.xxx	700 - 7,000 N·m, 1½" sq. dr. M/F

* UKAS accredited calibration up to 6,000 N·m. A non-accredited value at 7,000 N·m is extrapolated and provided for reference only.

4	TRANSDUCERS FOR USE WITH 80029 / 80030
50776.xxx@	1,000 - 10,000 N·m, 2½" sq. dr. M/F
50777.xxx@	1,000 - 10,000 lbf-ft, 2½" sq. dr. M/F
50797.xxx@	2,500 - 25,000 N·m, 2½" sq. dr. M/F
50781.xxx@	5,000 - 50,000 N·m, 2½" sq. dr. M/F
50798.xxx@	25,000 lbf-ft, 2½" sq. dr. M/F

4	TRANSDUCERS FOR USE WITH 80032
50782.xxx	6,000 - 60,000 lbf-ft, 3½" sq. dr. M/F
50783.xxx	8,000 - 80,000 N·m, 3½" sq. dr. M/F

Harsh Environment Transducers available on request.

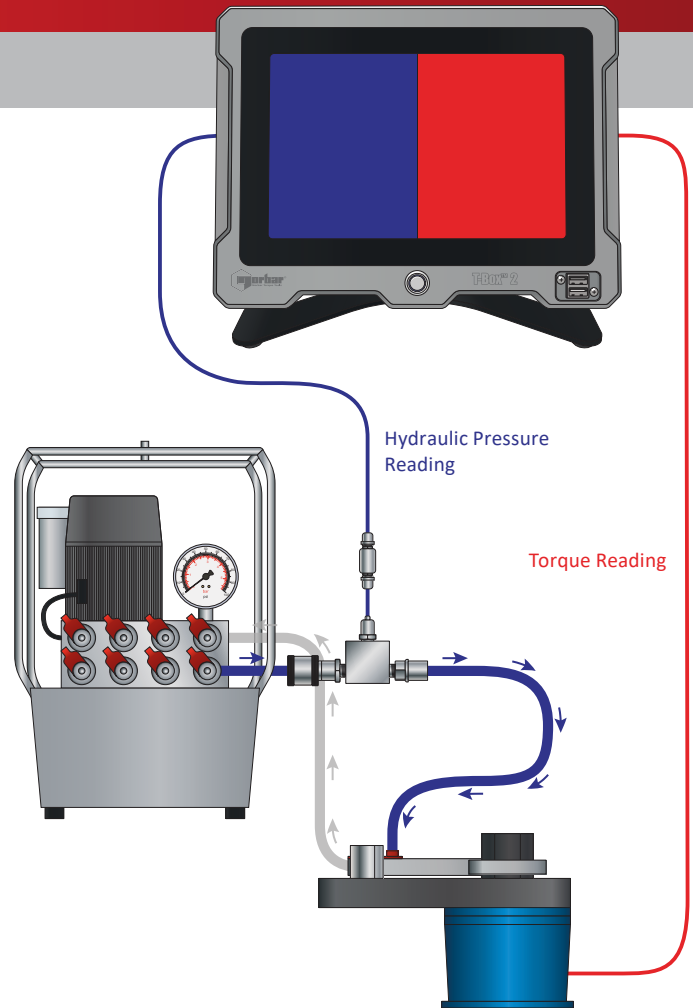

4 CALIBRATION FIXTURE ACCESSORIES

56026.IND 730 bar Pressure Transducer



56026.IND 730 bar Pressure Transducer

9 ADDITIONAL CALIBRATION

The transducers shown include clockwise only calibration from 10% to 100% of rated capacity. For other calibration options, see below:

***ADDCALPOINTS.NEW**
Additional calibration steps below 10% of rated capacity to 2% for transducers up to 7,000 N·m (5,000 lbf-ft) when ordered with new unit @SECCAL.CW

Secondary calibration in one direction on static transducers with 2½" square drives to extend the range below 10% of the rated capacity, when ordered with new unit

SECCAL.CW+CCW
Secondary calibration in two directions on static transducers with 2½" square drives to extend the range below 10% of the rated capacity, when ordered with new unit



HEXAGON TO SQUARE ADAPTORS



Hexagon to Square Adaptor

9	HEXAGON TO SQUARE ADAPTORS - METRIC
29619.24	24 mm Hex to 1½" sq. dr. (Max 3,000 N·m)
29619.27	27 mm Hex to 1½" sq. dr. (Max 4,000 N·m)
29619.30	30 mm Hex to 1½" sq. dr. (Max 4,000 N·m)
29619.32	32 mm Hex to 1½" sq. dr. (Max 4,900 N·m)
29619.36	36 mm Hex to 1½" sq. dr. (Max 7,000 N·m)
29619.41	41 mm Hex to 1½" sq. dr. (Max 8,700 N·m)
29619.46	46 mm Hex to 1½" sq. dr. (Max 8,700 N·m)
29619.50	50 mm Hex to 1½" sq. dr. (Max 8,700 N·m)
29619.55	55 mm Hex to 1½" sq. dr. (Max 8,700 N·m)
29619.60	60 mm Hex to 1½" sq. dr. (Max 8,700 N·m)
29619.65	65 mm Hex to 1½" sq. dr. (Max 8,700 N·m)
29619.70	70 mm Hex to 1½" sq. dr. (Max 8,700 N·m)
29619.75	75 mm Hex to 1½" sq. dr. (Max 8,700 N·m)
29619.80	80 mm Hex to 1½" sq. dr. (Max 8,700 N·m)
29620.50	50 mm Hex to 2½" sq. dr. (Max 18,500 N·m)
29620.55	55 mm Hex to 2½" sq. dr. (Max 25,000 N·m)
29620.60	60 mm Hex to 2½" sq. dr. (Max 32,000 N·m)
29620.65	65 mm Hex to 2½" sq. dr. (Max 36,000 N·m)
29620.70	70 mm Hex to 2½" sq. dr. (Max 36,000 N·m)
29620.75	75 mm Hex to 2½" sq. dr. (Max 36,000 N·m)
29620.80	80 mm Hex to 2½" sq. dr. (Max 59,000 N·m)
29620.85	85 mm Hex to 2½" sq. dr. (Max 59,000 N·m)
29620.90	90 mm Hex to 2½" sq. dr. (Max 59,000 N·m)
29620.95	95 mm Hex to 2½" sq. dr. (Max 59,000 N·m)
29620.100	100 mm Hex to 2½" sq. dr. (Max 52,000 N·m)
29620.105	105 mm Hex to 2½" sq. dr. (Max 52,000 N·m)
29620.110	110 mm Hex to 2½" sq. dr. (Max 52,000 N·m)
29620.115	115 mm Hex to 2½" sq. dr. (Max 52,000 N·m)
29620.130	130 mm Hex to 2½" sq. dr. (Max 52,000 N·m)

9	HEXAGON TO SQUARE ADAPTORS - IMPERIAL
29623.I20	1¼" Hex to 1½" sq. dr. (Max 4,900 N·m)
29623.I23	1⅜" Hex to 1½" sq. dr. (Max 7,000 N·m)
29623.I26	1⅝" Hex to 1½" sq. dr. (Max 8,700 N·m)
29623.I29	1⅞" Hex to 1½" sq. dr. (Max 8,700 N·m)
29623.I32	2" Hex to 1½" sq. dr. (Max 8,700 N·m)
29623.I33	2⅛" Hex to 1½" sq. dr. (Max 8,700 N·m)
29623.I35	2⅜" Hex to 1½" sq. dr. (Max 8,700 N·m)
29623.I38	2⅝" Hex to 1½" sq. dr. (Max 8,700 N·m)
29623.I41	2⅞" Hex to 1½" sq. dr. (Max 8,700 N·m)
29624.I35	2⅜" Hex to 2½" sq. dr. (Max 25,000 N·m)
29624.I38	2⅝" Hex to 2½" sq. dr. (Max 32,000 N·m)
29624.I40	2½" Hex to 2½" sq. dr. (Max 36,000 N·m)
29624.I41	2⅞" Hex to 2½" sq. dr. (Max 36,000 N·m)
29624.I44	2¾" Hex to 2½" sq. dr. (Max 36,000 N·m)
29624.I47	2⅝" Hex to 2½" sq. dr. (Max 36,000 N·m)
29264.I48	3" Hex to 2½" sq. dr. (Max 36,000 N·m)
29624.I50	3⅞" Hex to 2½" sq. dr. (Max 59,000 N·m)
29624.I56	3½" Hex to 2½" sq. dr. (Max 59,000 N·m)
29624.I62	3⅞" Hex to 2½" sq. dr. (Max 52,000 N·m)
29624.I68	4¼" Hex to 2½" sq. dr. (Max 52,000 N·m)
29624.I74	4⅝" Hex to 2½" sq. dr. (Max 52,000 N·m)
29624.I80	5" Hex to 2½" sq. dr. (Max 52,000 N·m)
29624.I86	5⅝" Hex to 2½" sq. dr. (Max 52,000 N·m)
29624.I98	6⅞" Hex to 2½" sq. dr. (Max 52,000 N·m)



Sleeve Adaptors

9	SLEEVE ADAPTORS
86034.4	Adaptor 1½" Male sq. dr. ¾" Female sq.
21214	Adaptor 1½" Male sq. dr. 1" Female sq.
290100	Adaptor 2½" Male sq. dr. ¾" Female sq.
290101	Adaptor 2½" Male sq. dr. 1" Female sq.
29617	Adaptor 2½" Male sq. dr. 1½" Female sq.
290103	Adaptor 3½" Male sq. dr. 1½" Female sq.
29618	Adaptor 3½" Male sq. dr. 2½" Female sq.

Special 'Engineer to Order' hexagon and square adaptors available on request.



TOOL CONTROLLERS

Tool Controllers 121

Norbar's Tool Controllers are used in a range of industries and applications where a high degree of tool control, automation or data gathering is required. In addition to the input of torque data, the controller can simultaneously take data from other sensors, such as angle or pressure, and the various inputs analysed together. It is possible, for example, to compare the inputs from multiple torque transducers or torque vs. angle or torque vs. pressure. In this way, Norbar Torque Controllers have been utilised in a diverse range of applications with typical examples being valve testing (torque vs. angle vs. time), automated hydraulic torque wrench testing (torque vs. pressure) and multi-spindle tool control. Logic within the Controller can be used to interface with other parts of a manufacturing or testing process to achieve go / no-go control for example, a process can be halted until certain measured parameters are met. Norbar's latest controller, illustrated below, uses a colour touch screen user interface for the easy input of details such as: test piece identifiers - type and serial number, operator name and specific targets to meet.

Examples of Norbar Tool Controllers are shown on page 121 but, in fact, these products are highly customised and will be engineered and programmed for our customers' specific requirements. For more details please visit the Engineer to Order section of the Norbar website at: www.norbar.com/Services/Engineer-to-Order or contact your Norbar distributor to discuss your requirements.





TOOL CONTROLLERS

The Tool Controller shut-off system is supplied in a wall box for 'External Control' versions of the Norbar PTM series of tools. This can give a much greater range of functionality than is possible on the 'Internal Control' version of the tool.

11 TOOL CONTROLLER (TTT based)

60244 Shut-off system in wall box
 Tool Controllers are supplied without leads.

- 61127.600 Lead for PTM Series Tool
- 61126.600 Transducer Lead for PT Series Tool
- 61128.600 Solenoid Lead for PT Series Tool (for single valve)

Other lead lengths can be ordered at an additional cost. Both 61126.600 and 61128.600 are required to control a PT Series tool with a tool controller.

11 TRANSDUCER LEADS FOR TOOL CONTROLLERS

- 61135.600 Transducer Lead for PTM-EC and Angle Series Tools, 6 m
- 61135.1000 Transducer Lead for PTM-EC and Angle Series Tools, 10 m
- 60308.400 PRO-LOG, TST, TTT, T-Box XL & T-Box 2 to Torque & Angle Annular Transducers
- 60308.600 PRO-LOG, TST, TTT, T-Box XL & T-Box 2 to Torque & Angle Annular Transducers
- 60308.1000 PRO-LOG, TST & TTT to Torque & Angle Annular Transducers

The models above are a sample of the controllers that Norbar produce. Please contact Norbar for your special requirements.

Tool Controller for Valve Testing

Tool controller for PneuTorque® remote tools fitted with annular torque & angle transducer and solenoid operated valve assemblies.

- 10" touchscreen HMI & PLC housed in a painted steel enclosure for indoor / workshop use
- Data entry fields for test valve details, operator, time, date, torque limits & angle / turns limits
- Forward / reverse cycling to user programmable number of cycles, variable up to 32,000°
- One torque transducer port, for 'LOGA' or 'LOG' connection
- One twin solenoid port for connection to valve assembly
- One hand pendant input port
- Two proximity limit switch ports (for use where angle is not measured at the transducer)
- One customer pressure sensor port, (2mV/V), for data recording (not tool shut-off)
- One RS232 + one USB data output ports
- Real time torque & angle or torque & turns data streaming
- Test data capture and output in CSV format onto external USB drive, for the generation of customer test reports & graphs
- Emergency stop button and torque overload limit function



Tool Controller with Hand Pendant from Valve Testing Controls Kit for use with AC servo drive or pneumatic drive tools

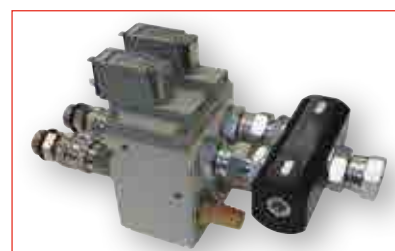

Example of Remote 108 Operating Valve Assembly fitted to a 108 Remote Motor Part No. 60309

This assembly includes two 3 way shut-off valves Part No. 28943

8 3 WAY SHUT-OFF VALVE

28943 | 3 Way Shut-off Valve 10 BAR Maximum Air Pressure

8 TWIN SOLENOID VALVE ASSEMBLY

- 60309 | Twin Solenoid Valve Assembly for 108 Remote Tools
- 60310 | Twin Solenoid Valve Assembly for 72 Remote Tools
- 60298.600* | Solenoid Lead for twin valve assembly, 6 m
- 60298.1000* | Solenoid Lead for twin valve assembly, 10 m

* For use with special tool controllers.



VALVE TESTING

Valve Testing & Actuation 123

Norbar's Valve Testing System has been designed to monitor and control the opening and closing of ball valves and gate valves by means of torque and/or angle measurement with optional proximity switches for added security when required.

Torque is applied using either:

Dual solenoid valves to control the forward and reverse rotation of any Norbar PneuTorque® remote series tool.

AC Servo motor that can be controlled in both the forward and reverse rotation. The system may also be cycled to a user pre-set number of counts. The control is provided by a touchscreen control panel with precision torque, angle and pressure measurement.





VALVE TESTING & ACTUATION

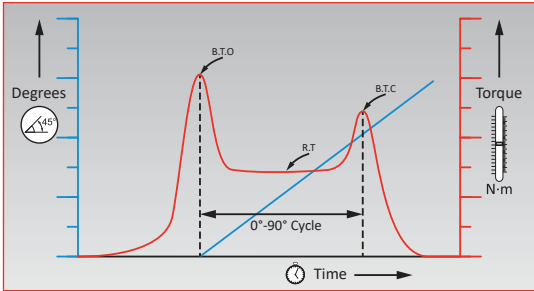

This diagram represents what we would expect to occur during a "break to open" to "break to close" cycle of a typical ball valve, with R.T. being the "run torque".



Example of a pneumatically driven PTS-72-1000 Remote fitted with torque and angle transducer as part of a Valve Testing System



VALVE TESTING SYSTEM

Engineered to order Valve Testing System

Typical applications include the testing of Ball Valves requiring cyclical rotation 0 - 90° / 90 - 0°, whilst recording torque vs angle data. Testing of Gate Valves / Valve Actuators by opening & closing whilst recording torque vs angle / turns data. The test must be remotely controlled from outside of the test chamber, where the test valve is pressurised.

- 10" touchscreen HMI & PLC housed in painted steel enclosure for indoor / workshop use
- Test data capture and output in CSV format onto external USB drive, time & date stamped
- Generate customer test reports and produce graphs
- Real time torque & angle or torque & turns data streaming via RS232 serial port
- Precision controlled low noise servo drive
- Operates Pneumatic (via solenoid valves), or servo drive tools
- Dedicated input ports for pressure, temperature and proximity sensors
- Controller available as separate component to upgrade existing valve testing kits
- Automatic recognition of Smart transducers
- Forward / reverse cycling- user programmable number of cycles, variable up to 32,000 sweeps
- Emergency stop button and torque overload limit function
- Utilises Norbar's tried and tested PneuTorque multiplier along with Torque and Angle Transducers- various capacities available
- Torque Range: 100- 300,000 N·m (capacities up to 500,000 available on application)
- Powerful brushless motor is quiet and maintenance free



Typical example of an engineered to order Valve Testing System in application



HARSH ENVIRONMENT INSTRUMENTS

Norbar has worked closely with the oil and gas industry to produce a range of torque instruments and transducers suitable for use in the harshest environments such as ship decks, oil rigs and refineries. Norbar uses a variety of corrosion resistant materials, high specification connectors and sealing techniques meaning that products in our HE range can be used in such environments without impairing their performance or life span. Although originally designed to meet the needs of the oil and gas industry, Norbar’s HE range is the ideal choice whenever it is necessary to apply or measure torque outdoors in potentially wet or dusty conditions.

Harsh Environment Instrument 125
 TTL-HE Instrument and Transducer Kits 125
 Harsh Environment Transducers 126
 Intervention Tool Test Pots 127
 Intervention Tool Verification Kits 128
 Multipliers for Subsea 128





HARSH ENVIRONMENT INSTRUMENT



TTL-HE is a portable torque measuring instrument designed for use in harsh environments. The TTL-HE operating on battery power with one of the 'HE' range of transducers connected, has an ingress protection rating of IP65/IP67. Typical operating environments are where high humidity, water or salt water spray and dust may be an issue. Features include; 10 measurement modes, 13 units of torque (with additional user units feature), 12 pairs of limits and text displayed in 11 languages.

- Instrument accuracy of $\pm 0.05\%$ ($\pm 0.1\%$ when below 10% of transducer capacity)
- System accuracy with a typical Norbar transducer, $\pm 0.5\%$ from 20% of transducer capacity
- IP65/67 rated
- Bi-directional calibration
- Battery power use in harsh environments (mains supply for charging)
- All features are in common with TST and TTT instruments
- Supplied in IP67 rated carry case
- 5 digit resolution for all Norbar transducers
- 240 x 64 pixel dot matrix display with update rate of twice per second
- Please contact Norbar for full details of available transducers

4 HARSH ENVIRONMENT RANGE

43217 TTL-HE Instrument (inc. IP67 rated carry case)
Supplied with clockwise and counter-clockwise calibration.

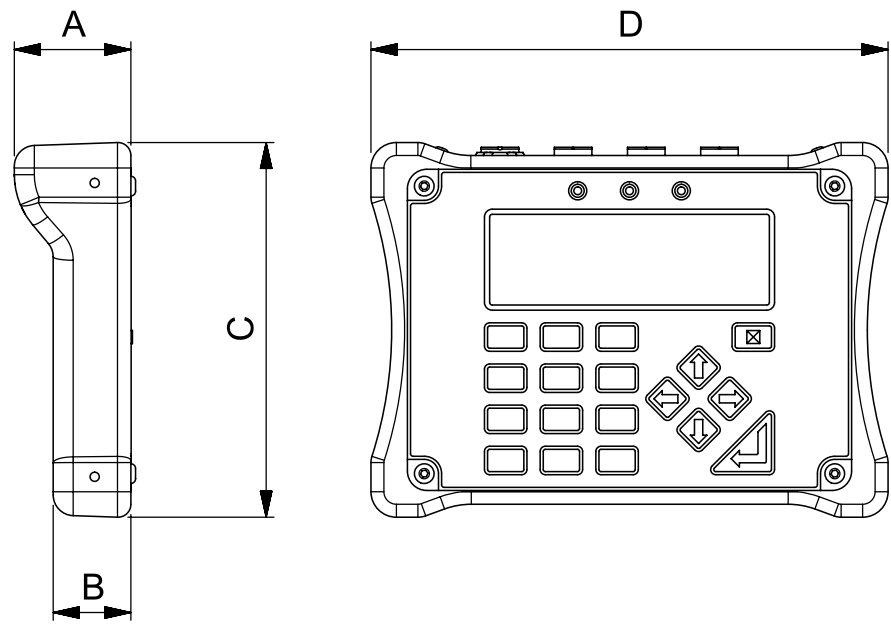

Model		TTL-HE
Part Number		43217
Dimensions (mm)	A	45
	B	30
	C	145
	D	200
Weight (kg)		4.9

TTL-HE INSTRUMENT AND TRANSDUCER KITS

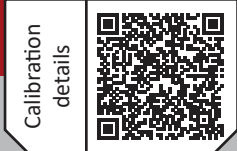

4	TTL-HE INSTRUMENT AND TRANSDUCER KITS	
60287.LOG	5,000 N·m M/M TTL-HE Kit, inc. Lead	(Class 4)
60295.LOG	10,000 N·m M/M TTL-HE Kit, inc. Lead	(Class 5)
60296.LOG	15,000 N·m M/M TTL-HE Kit, inc. Lead	(Class 6)
60289.LOG	40,000 N·m M/M TTL-HE Kit, inc. Lead	(Class 7)

Note: Kits for use with Intervention Tool Test Pots



HARSH ENVIRONMENT TRANSDUCERS



The accuracy and quality of the Norbar torque transducers has made them the first choice of many calibration laboratories throughout the world. The Harsh Environment range of transducers has been specifically designed for use with the Norbar TTL-HE instrument.

- Class 1 accuracy over the 'Primary' classification range ($\pm 0.5\%$ of reading from 20 to 100% of full scale)
- IP65/IP67 rated
- Stainless steel design with Smart intelligence
- Bi-direction calibration as standard



4	STATIC TRANSDUCERS
50787.xxx	300 - 3,000 N·m, 1½" M/F sq. dr.
50751.xxx*	300 - 3,000 N·m, 1½" M/M sq. dr.
50705.xxx	500 - 5,000 N·m, 1½" M/F sq. dr.
50729.LOG	500 - 5,000 N·m, 1½" M/M sq. dr.
50706.xxx	500 - 5,000 lbf-ft, 1½" M/F sq. dr.
50728.xxx	1,000 - 10,000 N·m, 2½" M/F sq. dr.
50788.xxx	1,000 - 10,000 N·m, 2½" M/ 2" M sq. dr.
50789.xxx	1,500 - 15,000 N·m, 2½" M/ 2½" M sq. dr.
50726.xxx	2,500 - 25,000 N·m, 3½" M/M sq. dr.
50727.xxx	4,000 - 40,000 N·m, 3½" M/M sq. dr.
50743.xxx*	10,000 - 100,000 lbf-ft, 3½" M/M sq. dr.

* Suitable for use in Hydraulic Test Pots.

+ UKAS accredited calibration up to 80,000 lbf-ft. A non-accredited value at 100,000 lbf-ft is extrapolated and provided for reference only. Static Transducers 3,000 N·m and above supplied in carry case.

Designed for use with the Harsh Environment Instrument range (TTL-HE) of products

4	INSTRUMENTATION LEADS
60245.200	TTL-HE to HE Transducer
60250.200	TTL-HE to Norbar Static & Annular Transducers
60263.200	TTL-HE to Rotary Transducers
60266.200	HE Transducer to TTT, TST and T-Box 2
60261.200	Serial Data Lead for TTL-HE

Other lengths can be ordered at an additional cost.

Note: The system should be calibrated with the increased length lead, as calibration may be affected.

Note: The maximum permissible cable length 15 m for Transducer Leads, 7 m if using 60266 with a T-Box™ XL. Contact Norbar for further details.

Static Transducers - Male to Male (M/M) Square Drives

Model	3,000 N·m 5,000 N·m	10,000 N·m	15,000 N·m	25,000 N·m 40,000 N·m 100,000 lbf-ft
Part Number	50751.xxx 50729.xxx	50788.xxx	50789.xxx	50726.xxx 50727.xxx 50743.xxx
Dimensions (mm)	ØA	95	110	164
	B	68	75	103
	C	168	200	225
	D	38	57	57
	E	84	101	101
	F	38	57	58
Weight (kg)	3.4 (3,000 N·m) 5.0 (5,000 N·m)	11.4	11.4	21.5 (25,000 N·m) 22.0 (40,000 N·m) 25.0 (100,000 lbf-ft)

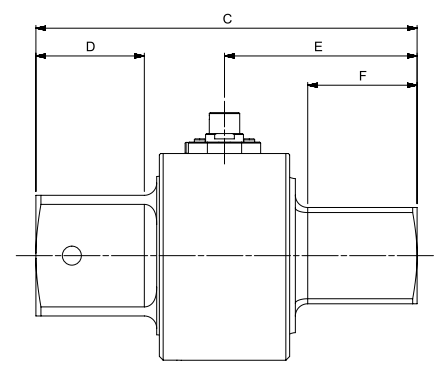
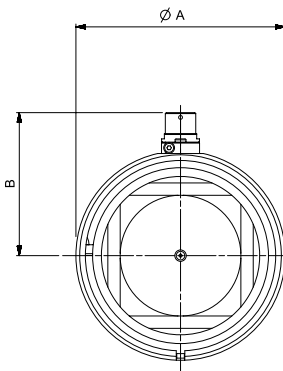

Static Transducers - Male to Female (M/F) Square Drives

Model	3,000 N·m 5,000 N·m 5,000 lbf-ft	10,000 N·m	
Part Number	50787.xxx 50705.xxx 50706.xxx	50728.xxx	
Dimensions (mm)	ØA	95	110
	B	68	83
	C	160	189
	D	41	59
	E	84	100
	F	38	57
Weight (kg)	5.0	9.1	

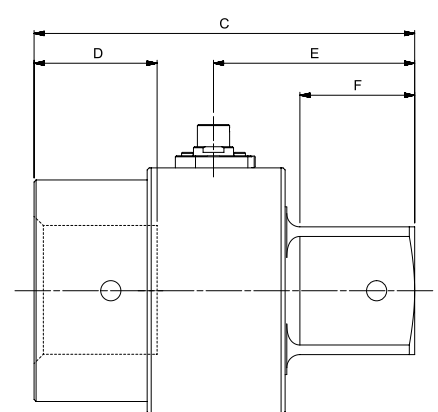
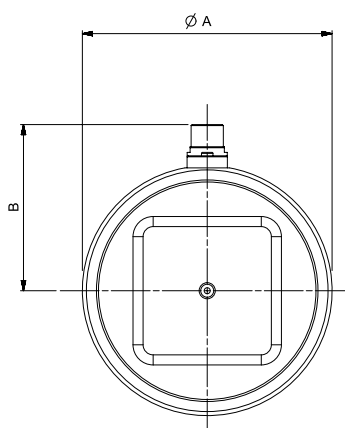



INTERVENTION TOOL TEST POTS



From left to right Intervention Tool Test Pots 80019, 80024, 80025 and 80020

These reaction pots allow for the accurate testing of API rotary intervention tools.

- Conform to ISO 13628-8:2002 and API 17D
- Customer specific solutions also available
- Lightweight construction, major components made in aluminium
- Incorporated lifting handles
- Eye bolts provided on larger units

4	INTERVENTION TOOL TEST POTS
80019	ISO 13628-8:2002 Class 4 Intervention Tool Test Pot
80024	ISO 13628-8:2002 Class 5 Intervention Tool Test Pot
80025	ISO 13628-8:2002 Class 6 Intervention Tool Test Pot
80020	API 17D Class 7 Intervention Tool Test Pot
81018	Deck Mount Kit for API Verification Pot

Model	Class 4	Class 5	Class 6	Class 7
Part Number	80019	80024	80025	80020
Dimensions (mm)	A	372	403	428
	B	215	246	326
Weight (kg)	17.5	22.0	51.0	48.0

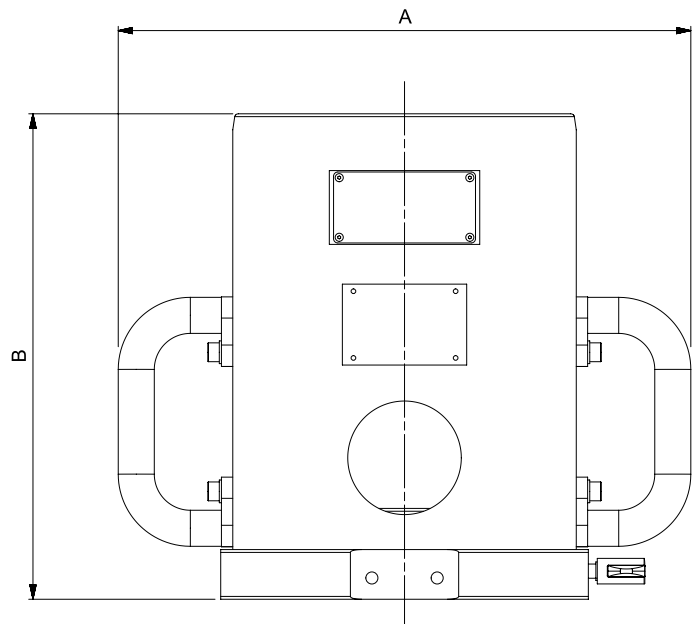



INTERVENTION TOOL VERIFICATION KITS



Calibration details



4	INTERVENTION TOOL TORQUE VERIFICATION KIT
60278.xxx	3,000 N·m ISO 13628 Class 4 Intervention Tool Torque Verification Kit
60281.xxx	10,000 N·m ISO 13628 Class 5 Intervention Tool Torque Verification Kit
60282.xxx	15,000 N·m ISO 13628 Class 6 Intervention Tool Torque Verification Kit
60279.xxx	25,000 N·m API 17D Class 7 (short) Intervention Tool Test Kit
60280.xxx	40,000 N·m API 17D Class 7 (short) Intervention Tool Test Kit

Other test pots and Torque Verification Kits are available for standard and non-standard API Intervention tool test and verification. Please contact Norbar.

MULTIPLIERS FOR SUBSEA

4	MULTIPLIERS FOR INTEGRATION INTO SUBSEA INTERVENTION TOOLS
77331	HT5 5:1 for Subsea Intervention Tools
77301	HT5 5:1 for Subsea Splined Output

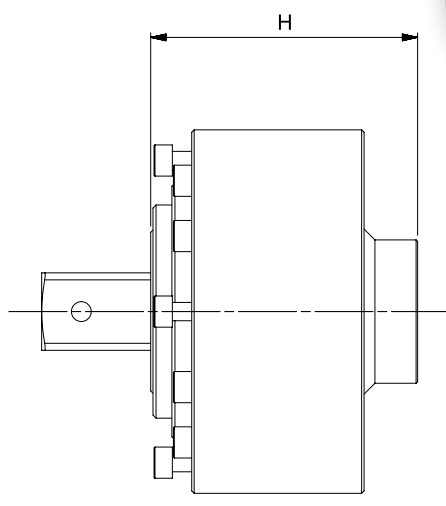
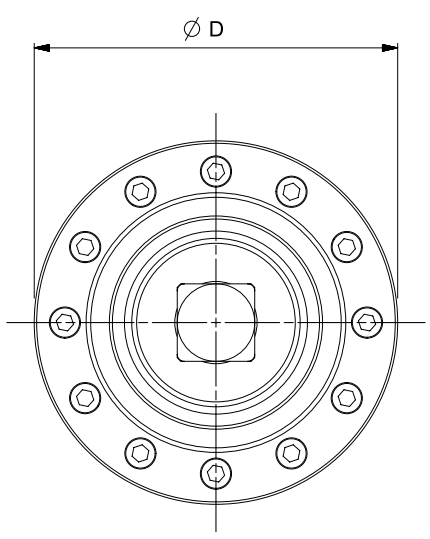

Model	HT5 5:1 Subsea	
Part Number	77331 77301	
Dimensions (mm)	D	119
	H	88
Weight (kg)	TBC	



ENGINEER TO ORDER

ETO Example 1 - NorTronic® Extension for Rail Industry 130
 ETO Example 2 - HT-72 Special Reaction & Socket for Ceramics Industry 130
 ETO Example 3 - Offset Gearbox to fit PTS-72-2000 for Train Traction Links 131
 ETO Example 4 - PTM-52 Offset Gearbox for Transportation Industry 131
 ETO Example 5 - ET2 with Remote Control Panel for Manufacturing Industry 132
 ETO Example 6 - Custom Class 7 Multiplier Kit with Hydraulic Latching for Subsea 133

Norbar's wide range of standard equipment may not meet your exact requirements as there are applications when something special is required.

As an ISO 9001 accredited company, Norbar will undertake the design and manufacture of special equipment against agreed customer specifications.

These projects range from modified torque wrench end fittings to complete torque and angle control of valve testing kits. Relevant safety directives are applied where appropriate, leading to well engineered reliable products that are designed to make tasks safer and easier.

For more information on Norbar's Engineer to Order service please e-mail your enquiry to technical@norbar.com or visit the Engineer to Order section of the Norbar website at: www.norbar.com/Support/Services/Engineer-to-Order



Class 4 to 20,000 N-m subsea torque multiplier & verification kit, for pipe clamp actuation



Model 60 'P' Type torque wrench, HandTorque® HT-52/22 and a 5 gear Offset Gearbox Kit for tightening Pintle Bolts



ETO EXAMPLE 1 - NORTRONIC® EXTENSION FOR RAIL INDUSTRY

Project number: Q4818 / Q4611 / Q3166

Introduction & Application

Railway clamp applications requiring bolt torque data logging at up to 500 N·m.

Solution

NorTronic® 330 less standard ratchet end i.e. with 16 mm male spigot.

Fitted with a Q4611 special extension bar to increase torque to 500 N·m.

Ratchet end fitting with push-through 3/4" square drive & 22 mm spigot # 29972.

Alternative large spanner ends with 22 mm spigot can also be fitted to Q4611 extension (e.g. Q3166).

Torque data is displayed on the tool, and can also be sent via Wireless connection or Bluetooth® to Norbar TDS software loaded on customer's PC / device.



440 N·m version with special 30 A/F ring spanner end shown (SP00005 / Q3166)



Q4611 500 N·m extension bar (16 mm female to 22 mm male spigots).



Technical Specification / Data Highlights

The customer can log the torque (and angle) data against their device GPS position and time of reading.

The NorTronic® is supplied with standard calibration to 330 N·m, and centres adjustment can be made in the NorTronic® software giving resulting range of 50 - 500 N·m.

ETO EXAMPLE 2 - HT-72 SPECIAL REACTION & SOCKET FOR CERAMICS INDUSTRY

Project number: Q4292

Introduction & Application

Ceramics industry maintenance requirement to tighten mill centre nut weekly to 1,700 N·m.

Solution

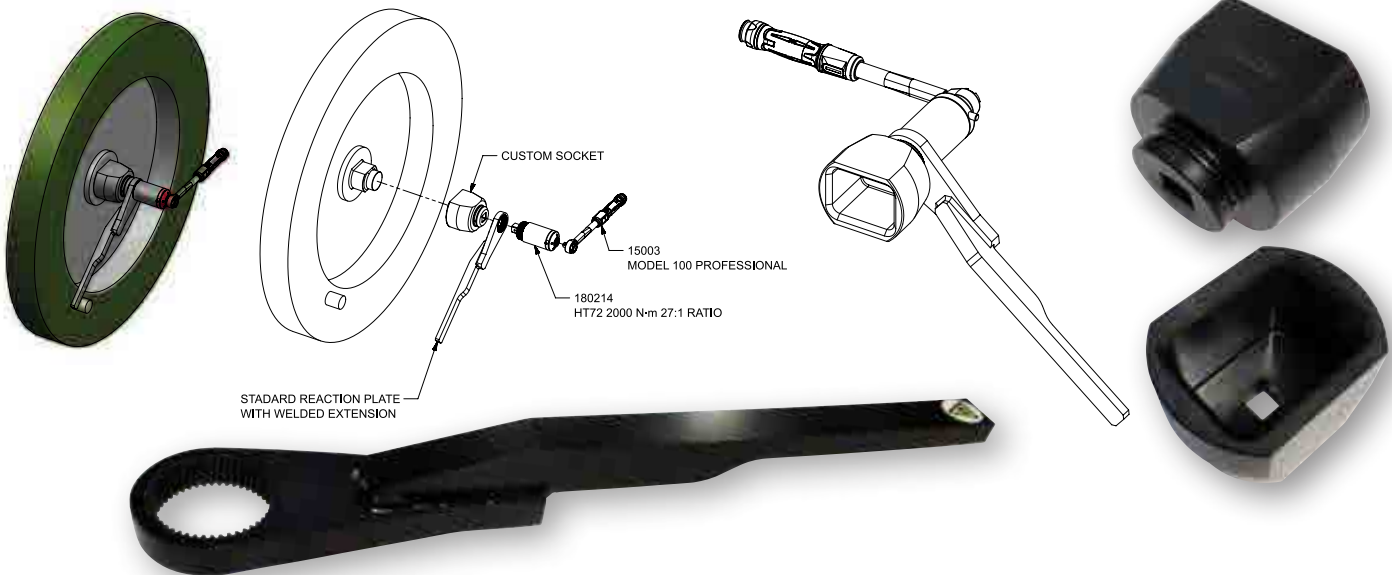

Technical Specification / Data Highlights

Special reaction arm & 1" square drive socket for use with HT-72-2000 27:1 & Model 100 torque wrench.



ETO EXAMPLE 3 - OFFSET GEARBOX TO FIT PTS-72-2000 FOR TRAIN TRACTION LINKS

Project number: Q4191

Introduction & Application

Railway maintenance application for removal & re-fitting of train traction link bolts, where bolt access is obstructed by the anti-roll bar.

Solution

PTS-72-2000 with offset gearbox kit.



Technical Specification / Data Highlights

M36 – 55 mm A/F hexagon head bolts tighten to 980 N·m / untighten at up to 2,000 N·m.

Q4191 kit includes offset gearbox having 3 gears, 177.8 mm offset distance, LH & RH reaction arms, PTS-72-2000 & Lubro control unit # 16074.

ETO EXAMPLE 4 - PTM-52 OFFSET GEARBOX FOR TRANSPORTATION INDUSTRY

Project number: Q3949

Introduction & Application

Commercial vehicle trailer manufacturer requires improved tooling to torque tighten various axle assembly M24 bolts, where access is restricted.

Solution

PneuTorque® PTM-52-800-B fitted with a 4-gear offset gearbox having integral post & lug reactions to suit the various applications, operating at 550 N·m typical torque.



Technical Specification / Data Highlights

4-gear offset gearbox having 205.74 mm offset distance and 800 N·m maximum torque capacity.

36 mm female hexagon output drive, with 1:1 (nominal) torque ratio.

13.0 Kg approx. weight with Xylan coated steel casings, and hardened steel gears running in bearings.



ETO EXAMPLE 5 - ET2 WITH REMOTE CONTROL PANEL FOR MANUFACTURING INDUSTRY

Project number: Q4523

Introduction & Application

Manufacturing assembly line torque & angle bolt tightening station.

Remote operated electric torque tool required having up to 6,000 N·m torque capacity with angle.

Solution

EvoTorque®2-119-6000 tool modified as follows:

- Display module removed (but used in below remote control panel).
- Blanking plate fitted in lieu of display, and housing sockets for trigger & communication leads.
- Handle indexing (relative to gearbox) locked.

Special control panel housing the ET2 display module taken from ET2 tool & 3.5 m communication lead.

Remote trigger handle assembly & 3.5 m lead.

Standard cranked reaction used (contacts vertical ribs on yellow sections).



Technical Specification / Data Highlights

Supply of a kit for integration into customer assembly machinery (having emergency stop isolator).

Fits to customer manipulator arm.

Second trigger switch could be supplied for two handed start function if preferred.

Other sizes of ET2 can be supplied for similar remote operation applications (see Q4940 for ET-72-1350).



ETO EXAMPLE 6 - CUSTOM CLASS 7 MULTIPLIER KIT WITH HYDRAULIC LATCHING FOR SUBSEA

Project number: Q3730

Introduction & Application

Oil & Gas industry requirement for a custom Class 7 torque multiplier kit with hydraulic latching, for integration into a pressure compensated subsea intervention tool.

Solution

Custom torque multiplier kit comprising:-

- Custom Class 7 nose housing with 2-stage torque multiplication gearing.
- HT5 / 5 torque multiplier & connecting input shaft.
- Hydraulic latching system with fail-safe spring return cylinders.

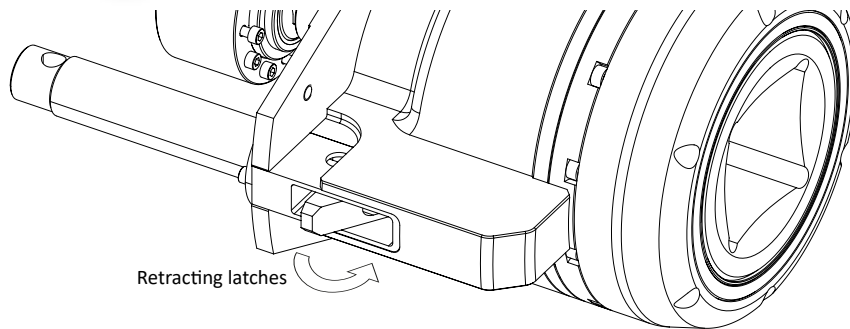

Technical Specification / Data Highlights

Class 7; 34,000 N·m (25,000 lbf·ft) with 61:1 torque multiplication.

Customised nose to suit end user's special receptacle (non-standard narrow reaction wings).

Sealed for use to 3,000 m (except input end), for connection to customer pressure compensation system.

High strength, lightweight materials for total weight in air of 59.9 Kg.



ULTRASONIC MEASUREMENT

USM-3 135

As design engineers push the boundaries to provide greater strength and efficiency in bolted joints, the use of torque, torque and angle, or even tensioning as the method of tension control may not be adequate, leading to costly failures. In those applications, ultrasonic bolt elongation/load measurement is able to provide accuracy equal to strain gauging without the need to strain gauge a bolt. In addition, the use of ultrasonic bolt measurement allows the user to return at any time and re-verify the level of tension in each fastener over its service life. The USM-3 has been both laboratory and field-proven to be the most accurate, reliable and cost effective solution for eliminating bolting failures. These could place workers at risk, lead to the loss of production and/or cause damage to capital equipment.





USM-3



Hire Only



Ultrasonic measurement provides a very precise method of determining the elongation of a fastener due to tightening. This elongation is proportional to the load force generated by the fastener.

The basic principle behind this method of tension control is similar to sonar. The ultrasonic measurement of bolt tension is achieved by introducing a sonic pulse at one end of the fastener and accurately measuring the time of flight (TOF) required for the echo to return from the opposite end. Using material constants, the USM-3 converts this TOF into an 'acoustic length' of the fastener, providing a baseline from which future measurements will be made. When the fastener is tightened: the TOF increases and the USM-3 will again utilise material constants to eliminate the effects of stress and temperature variations on sound velocity, providing an accurate elongation or load measurement.

The USM-3 uses state of the art hardware and digital signal processing to achieve these measurements with maximum automation, minimizing the need for operator interpretation. Once measurements have been recorded to the USM-3 internal memory, the included SonicBolt software will transfer the data to a computer for backup of files, creation of project reports, and conversion of data to Excel format for further analysis. In addition, the analogue signal output can be used to automatically shut-off powered torque and tensioning tools based on elongation or load, in even the most demanding applications.

Model	USM-3	
Part Number	40334	
Dimensions (mm)	A	53
	B	240
	C	180
Weight (kg)	2.3	

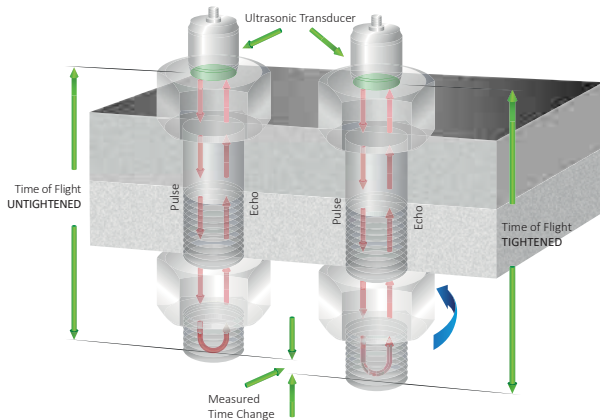

9 USM-3 ULTRASONIC STRESS METER

40334 USM-3 instrument with AC adaptor, nylon case, storage case, transducer cable, RS-232 cable, couplant and manual

Magnetic Transducers - This standard style is used with ferrous materials, and consists of a rare earth magnet surrounding the piezo electric transducer.

9 TRANSDUCERS

56016	3/16" 5 MHz Magnetic Transducer
56017	3/16" 7.5 MHz Magnetic Transducer
56018	3/16" 10 MHz Magnetic Transducer
56009	1/4" 5 MHz Magnetic Transducer
56019	1/4" 10 MHz Magnetic Transducer
56011	1/2" 2.25 MHz Magnetic Transducer
56010	1/2" 5 MHz Magnetic Transducer
56020	3/4" 1 MHz Magnetic Transducer
56013	3/4" 2.25 MHz Magnetic Transducer
56012	3/4" 5 MHz Magnetic Transducer
56021	Glue on, 3 mm square, 7.5 MHz, pack of 100

Operating temperature limit for transducers is 55°C. Contact Norbar for details of high temperature transducers with a temperature limit of 175°C.

9 TRANSDUCER LEADS

60235	Transducer Lead 10' (approx 3 m)
60236	Transducer Lead 20' (approx 6 m)
Q2408	Probe for glue on Ultrasonic TD's

9 SPARES & ACCESSORIES

61112	Ultrasonic Couplant Bottle 4 oz (approx 0.12 litres)
61116	Serial Lead 6' DB9 M to DB9 F
61117	Length Bar Set 3" & 6" with certificate
60271	Digital Thermometer (Accuracy ±0.5°C / ±1°F)

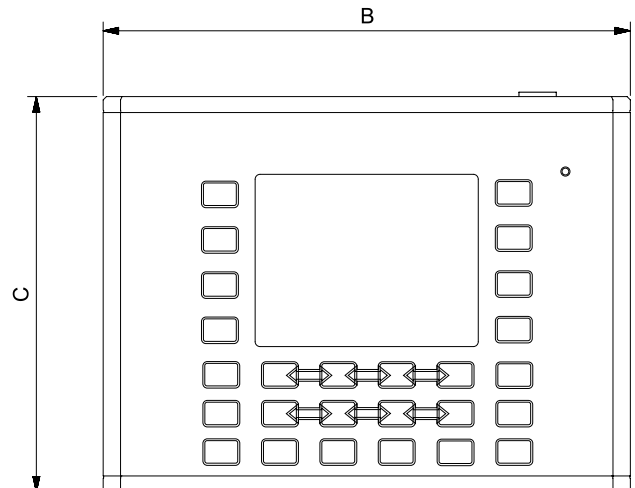
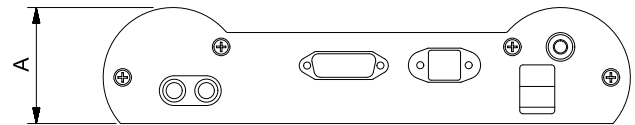



CALIBRATION BEAMS & WEIGHTS

Designed to remove potential sources of measurement error, these beams can be used to calibrate Norbar torque transducers, and torque transducers from other manufacturers (where design permits), as well as mechanical test devices. A UKAS accredited calibration certificate for the measurement of the torque radius is provided with each beam. Note: A temperature controlled environment is essential for use of these beams. The selection of weights will be influenced by gravitational constant at the proposed laboratory site.

Calibration Beams & Weights - Principles of Operation 137
 Calibration Beams & Weights - Metric 138
 Calibration Beams & Weights - Imperial 139
 Calibration Certificates 140





CALIBRATION BEAMS & WEIGHTS - PRINCIPLES OF OPERATION

Norbar's test beams are designed for the static calibration of torque transducers. They are ideally suited to Norbar's transducers, but can be employed on other manufacturer's equipment.

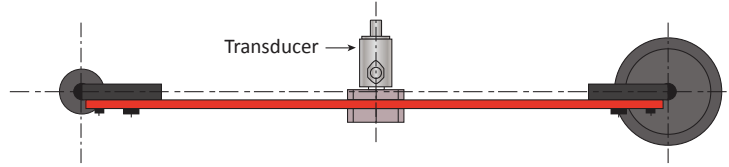

Torque is generated by the application of a known force at a known radius from the centre of rotation of the torque transducer.

The beams are designed with square drives machined to the top limit of ISO 1174. This minimises any play between the beam and the transducer. However, a combination of square drive tolerances, misalignment of fittings and elastic rotation of the transducer shaft inevitably cause the beam to rotate from the horizontal under load.

Norbar's radius ended beams are designed with a $\pm 8^\circ$ usable arc. Using the full 8° , calibrations to a best class of 0.5 can be carried out. With the additional use of Transducer Calibration Fixtures and 3° Angled Plate (see page 139), a best class of 0.1 can be achieved.

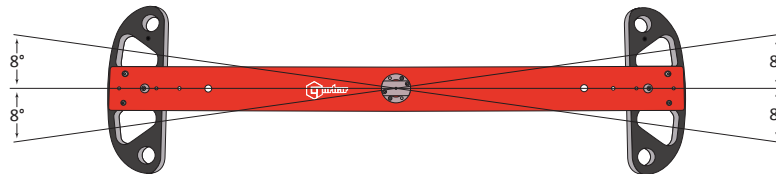
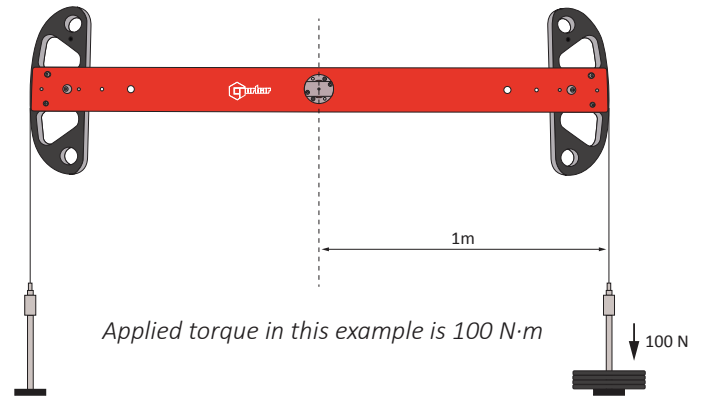

Additionally, the beams are designed to apply load on a vertical plane which cuts through the square drive inside the transducer. This minimises bending moments on the transducer and for safe operation, ensures that the beam will not fall out of the transducer.

Gravitational Effects

It is very important that the gravitational value for the laboratory is established. The effect of not doing this could be a variation in the force produced by the weight of perhaps 0.5% of reading.

It is therefore strongly recommended that you establish the local value of gravity (g) for your laboratory and use weights that have been calibrated at that gravitational constant.

Norbar will supply weights calibrated to gravitational constants specified by the customer. However, if the customer does not specify a value for 'g' they will have been calibrated at an estimated gravitational constant for the customers' location.

Buoyancy Effects

The Norbar system uses calibrated weights to generate a downwards force.

This means that Archimedes' principle applies, ie. air pressure under the weights causes an upwards force. This reduces the effective force generated by the weights and therefore the mass must be increased to allow for this.

Under standard conditions (i.e. air density 1.2 kg/m³ and 20° centigrade and working in conventional mass terms) the increase required is by a factor of 0.015%.

Weights purchased from Norbar will already have this factor taken into account.

Weights that are calibrated to standard procedures do not have this factor taken into account because the air buoyancy affects both sides of the mass balance and can be ignored. It is important that weights used for torque transducer calibration are adjusted for air buoyancy.

It should also be noted that the double ended beam design employed by Norbar means that each half of the beam is balanced with regard to buoyancy of the beam. This is a significant advantage over single-arm counterbalanced systems.



CALIBRATION BEAMS & WEIGHTS - METRIC



Calibration details



9	METRIC - NEWTON METRE SIZES	
21400	3 N-m	Torque Radius Disc (100 mm)
21429	60 N-m	Radius Ended Beam (0.25 m)
21421	150 N-m	Radius Ended Beam (0.5 m)
21427	500 N-m	Radius Ended Beam (0.5 m)
21428	1,500 N-m	Radius Ended Beam (1.0 m)
21842	7,000 N-m	Free Standing Beam

With the exception of 21842 all calibration beams are supplied in a protective case. A UKAS accredited calibration certificate for the measurement of the torque radius is provided with each beam.

9	WEIGHTS FOR THE DISC 21400	
21452.NAM	Brass weight set to give 0.5 N-m	(10 x 0.5 N)
21450.NAM	Brass weight set to give 1.0 N-m	(10 x 1.0 N)
21479.NAM	Brass weight set to give 2.5 N-m	(10 x 2.5 N)

9	WEIGHTS FOR THE BEAM 21429	
21476.NAM	Cast iron weight set to give 5 N-m	(10 x 2 N)
21454.NAM	Cast iron weight set to give 10 N-m	(10 x 4 N)
21458.NAM	Cast iron weight set to give 50 N-m	(10 x 20 N)
Q2343.NAM	Cast iron weight set to give 60 N-m Optimised for the Pro-Test 60	(1 x 4.8 N, 1 x 7.2 N, 1 x 12 N, 1 x 24 N, 4 x 48 N)

9	WEIGHTS FOR THE BEAM 21421	
21477.NAM	Cast iron weight set to give 50 N-m	(10 x 10 N)
21458.NAM	Cast iron weight set to give 100 N-m	(10 x 20 N)

9	WEIGHTS FOR THE BEAM 21427/21428	
21459.NAM	Cast iron weight set to give 250/500 N-m	(1 x 10 N, 10 x 50 N)
21460.NAM	Cast iron weight set to give 500/1,000 N-m	(1 x 10 N, 10 x 100 N)
21483.NAM	Cast iron weight set to give 500/1,000 & 1,500 N-m	(14 x 100 N, 1 x 50 N, 2 x 20 N, 1 x 10 N)

e.g. set 21459.NAM will give 250 N-m on a 21427 beam and 500 N-m on a 21428.

9	WEIGHTS FOR THE BEAM 21842	
21469.NAM	Cast iron weight set to give 7,000 N-m	(20 x 50 lbf)

All weight sets come with traceable UKAS accredited calibration certificate. This requires the customer to provide the value for 'g' (local gravity) for the intended place of use when ordering.



Model	100 mm Disc	0.25 m Beam	0.5 m Beam	0.5 m Beam	1 m Beam	Free Standing Beam
Part Number	21400	21429	21421	21427	21428	21842
Minimum Torque (N-m)	0.05	0.5	5	50	10	350
Dimensions (mm)	A	100	250	500	500	1,000
	B max.	295	650	755	1,015	1,015
Weight (kg)	0.5	1.9	5.0	17.0	25.0	270.0

* A max. Torque Radius for 7,000 N-m beam

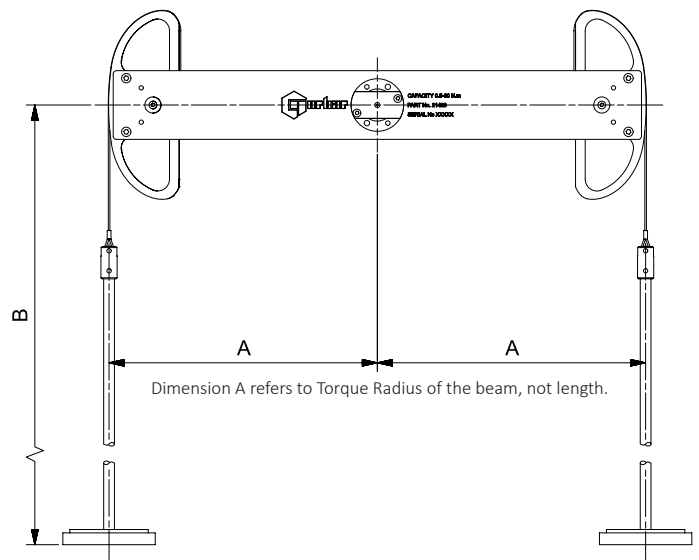



CALIBRATION BEAMS & WEIGHTS - IMPERIAL



Calibration details

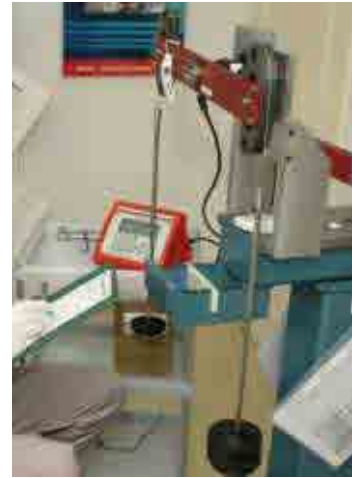

9 IMPERIAL - POUNDS FEET SIZES	
21400	25 lbf-in Torque Radius Disc (100 mm)
21430	500 lbf-in Radius Ended Beam (10")
21424	100 lbf-ft Radius Ended Beam (12")
21425	500 lbf-ft Radius Ended Beam (24")
21426	1,000 lbf-ft Radius Ended Beam (48")
21842	5,000 lbf-ft Free Standing Beam

With the exception of 21842 all calibration beams are supplied in a protective case. A UKAS accredited calibration certificate for the measurement of the torque radius is provided with each beam.

9 WEIGHTS FOR THE DISC 21400	
21455.NAM	Brass weight set to give 50 ozf-in (10 x 1.27 ozf)
21453.NAM	Brass weight set to give 100 ozf-in (10 x 2.54 ozf)
21451.NAM	Brass weight set to give 160 ozf-in (10 x 4.064 ozf)

9 WEIGHTS FOR THE BEAM 21430	
21465.NAM	Cast iron weight set to give 100 lbf-in (10 x 1 lbf)
21466.NAM	Cast iron weight set to give 500 lbf-in (10 x 5 lbf)

9 WEIGHTS FOR THE BEAM 21424	
21467.NAM	Cast iron weight set to give 100 lbf-ft (10 x 10 lbf)

9 WEIGHTS FOR THE BEAM 21425	
21468.NAM	Cast iron weight set to give 500 lbf-ft (10 x 25 lbf)

9 WEIGHTS FOR THE BEAM 21426	
21468.NAM	Cast iron weight set to give 1,000 lbf-ft (10 x 25 lbf)

9 WEIGHTS FOR THE BEAM 21842	
21469.NAM	Cast iron weight set to give 5,000 lbf-ft (20 x 50 lbf)

All weight sets come with a traceable UKAS accredited calibration certificate. This requires the customer to provide the value for 'g' (local gravity) for the intended place of use when ordering.

Model	100 mm Disc	10" Beam	12" Beam	24" Beam	48" Beam	Free Standing Beam
Part Number	21400	21430	21424	21425	21426	21842
Minimum torque	0.44 lbf-in	10 lbf-in	10 lbf-ft	50 lbf-ft	100 lbf-ft	300 lbf-ft
Dimensions (mm)	A	100	254	305	610	* 1,524
	B max.	295	650	690	965	1,015
Weight (kg)	0.5	1.2	3.7	17.3	26.4	270.0

* A max. Torque Radius for 5,000 lbf-ft beam

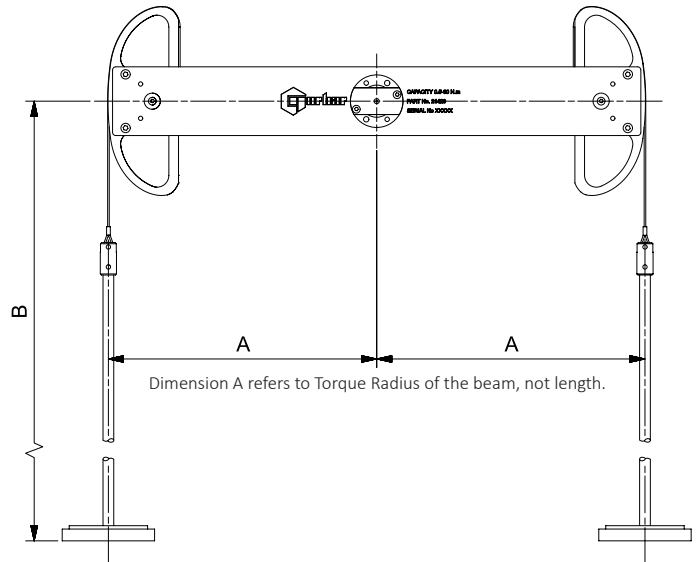

9 ANCILLARY PRODUCTS FOR CALIBRATION BEAMS	
J2676	1,500 N.m Calibration Pedestal
J2329	Pro-Test Calibration Test Rig Assembly
80005	Adjustable Angle Attachment

9 CALIBRATION FIXTURES	
J5042.025	Transducer calibration fixture 1/4" sq
J5042.0375	Transducer calibration fixture 3/8" sq
J5042.05	Transducer calibration fixture 1/2" sq
J5042.075	Transducer calibration fixture 3/4" sq
J5042.1	Transducer calibration fixture 1" sq
J3305	3° Angled Plate for use with calibration fixtures



CALIBRATION CERTIFICATES



As a UKAS accredited calibration Laboratory No. 0256, Norbar is required to calibrate torque measuring devices that are within the laboratory's scope, in accordance with BS 7882:2017. See the 'UKAS Schedule of Accreditation' on the 'Calibration Services' page of our website, www.norbar.com.

Norbar can provide a comprehensive range of calibrations including increasing and decreasing torques; clockwise and counter-clockwise; in either SI or English torque units, or in mV/V or Volts.

The sections below summarise the main features of BS 7882:2017, but purchase and careful study of the standard is advised for those who wish to have more detailed information.

Procedure

- The 'device' is defined as all parts of a system, e.g. Display, Transducer cable and Transducer. Transducer cables will therefore be serial numbered if they are separate items.
- The output of the device is defined as 'deflection'.
- It is preferable to calibrate all parts of a system together. If a transducer is sent for calibration without its normal display unit, an equivalent calibrated display held in the laboratory will be used. The normal display must also be in a calibrated state or the certification for the transducer is invalidated.
- Norbar is currently the only laboratory accredited by UKAS for the calibration of Electrical Torque Measuring Indicators.
- Before any calibration or recalibration the torque measuring device is preloaded three times in succession to the maximum applied torque of the device. Each preload is maintained for a minimum of 30 seconds to exercise the device and stabilise it in the calibration fixture.
- The device is calibrated with at least five approximately equal steps from 20% to 100% of maximum torque. Lower values are allowed as long as they meet certain criteria for resolution.
- For classes 0.05 and 0.1, it is mandatory to calibrate the torque measuring device in four different mounting positions each rotated 90° about the measurement axis. For all other classes the device is calibrated at a minimum of two different mounting positions at least 90° apart.
- Two series of readings are taken, and the device is then disturbed, generally by being disconnected from the calibration fixture and rotated through 90°. The device is then preloaded once to full scale. A third series of readings are then taken. This process is repeated until readings have been recorded in all required orientations.
- If reversibility is required, a single series of decreasing torques are applied at the end of the last increasing series.
- Should calibration be required in both directions, the series of readings are repeated in the opposite direction.
- The calibration data is then analysed to establish the following parameters.

Repeatability

The variation between the indicated deflection from series 1 and 2, expressed as a percentage of the mean of the two readings.

Reproducibility

The maximum variation between series 1, 2 and 3, or series 1, 2, 3, 4 and 5 expressed as a percentage of the mean indicated deflection calculated from series 1, 3 or series 1, 3, 4, and 5.

Error of Indication

Where the results are expressed in units of torque, the errors of indication are the variation between each applied torque and the mean indicated deflection at that torque.

Error of Zero Torque

The maximum zero reading recorded after each loading series is expressed as a percentage of the maximum mean indicated deflection.

Error of Interpolation

Where the results are expressed in volts or units other than torque units, a second order polynomial equation (best fit line) is established and the difference in deflection from the computed value is expressed as a percentage of the computed value.

Reversibility

The variation between the readings from the last torque series applied in an increasing mode and the readings for the same given torque applied in a decreasing mode. Reversibility is expressed as a percentage of the deflection of the last increasing series for the given torque.

Classification

- The parameters are each compared with a table to establish the device's classification. Class 0.05 is the highest performance, and class 5 is the lowest defined by the standard. The overall class reported will be that of the lowest performing parameter. For example reproducibility may be a class 1 when all other parameters meet class 0.5. The device will be classified as 1.
- Additionally the uncertainty of measurement of the applied torque must be five times better than the overall class reported. Norbar's uncertainty of measurement (typically 0.02%) allows classification to Class 0.1 devices.
- Different classes may be quoted for ranges below 20% of maximum capacity.

Relative Measurement Uncertainty Interval

The relative measurement uncertainty interval of the device is also calculated by combining the relative mean deviation with the relative expanded uncertainty.

Effectively the uncertainty interval encompasses all of a transducers reported errors and uncertainty of calibration, providing the user with a maximum error value of the calibrated device.

Accredited calibrations performed to BS 7882:2017 meet the requirements of BS EN ISO6789-2:2017 clause 4.3 and annex C 7.3, and BS EN ISO 6789-1:2017 clause 6.1.

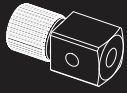

SPARES KITS

In order to maintain the quality, performance and peace of mind associated with our products Norbar recommend that only genuine Norbar spares are fitted to our products.

SERVICE REPLACEMENT POLICY

Our aim is to give you the fastest possible service when you send in a wrench for repair. Therefore, our policy is that all Norbar wrenches will, at Norbar's discretion, either be repaired or a 'service replacement' tool will be offered. This policy may be extended to wrenches from other manufacturers sent to Norbar for repair/replacement.

Repair

Where Norbar judges that a repair is viable, a combined repair and 'declaration of conformance' (COMBO) service will be offered – see page 146 for pricing. The setting of the wrench and documentation of the results will be carried out in conformance with ISO 6789-1:2017. For customers requiring a calibration certificate conforming to ISO 6789-2:2017 from Norbar's UKAS accredited laboratory, this service can also be offered at an additional cost.

Service Replacement

When Norbar judges that a repair is not commercially viable, a 'service replacement' tool will be offered. A 'service replacement' tool is manufactured from new parts, carries a twelve month warranty and is supplied with the same documentation as a new product of the equivalent type. For Professional, adjustable models from Model 15 to Model 1500 a calibration certificate conforming to ISO 6789-2:2017 will be supplied as standard from the production line. All other service replacement models, for example NorTorque® and TTi wrenches, will be supplied with a Declaration of Conformance to ISO 6789-1:2017. As with repairs, customers preferring a certificate from Norbar's UKAS accredited laboratory can specify this service at an additional cost.

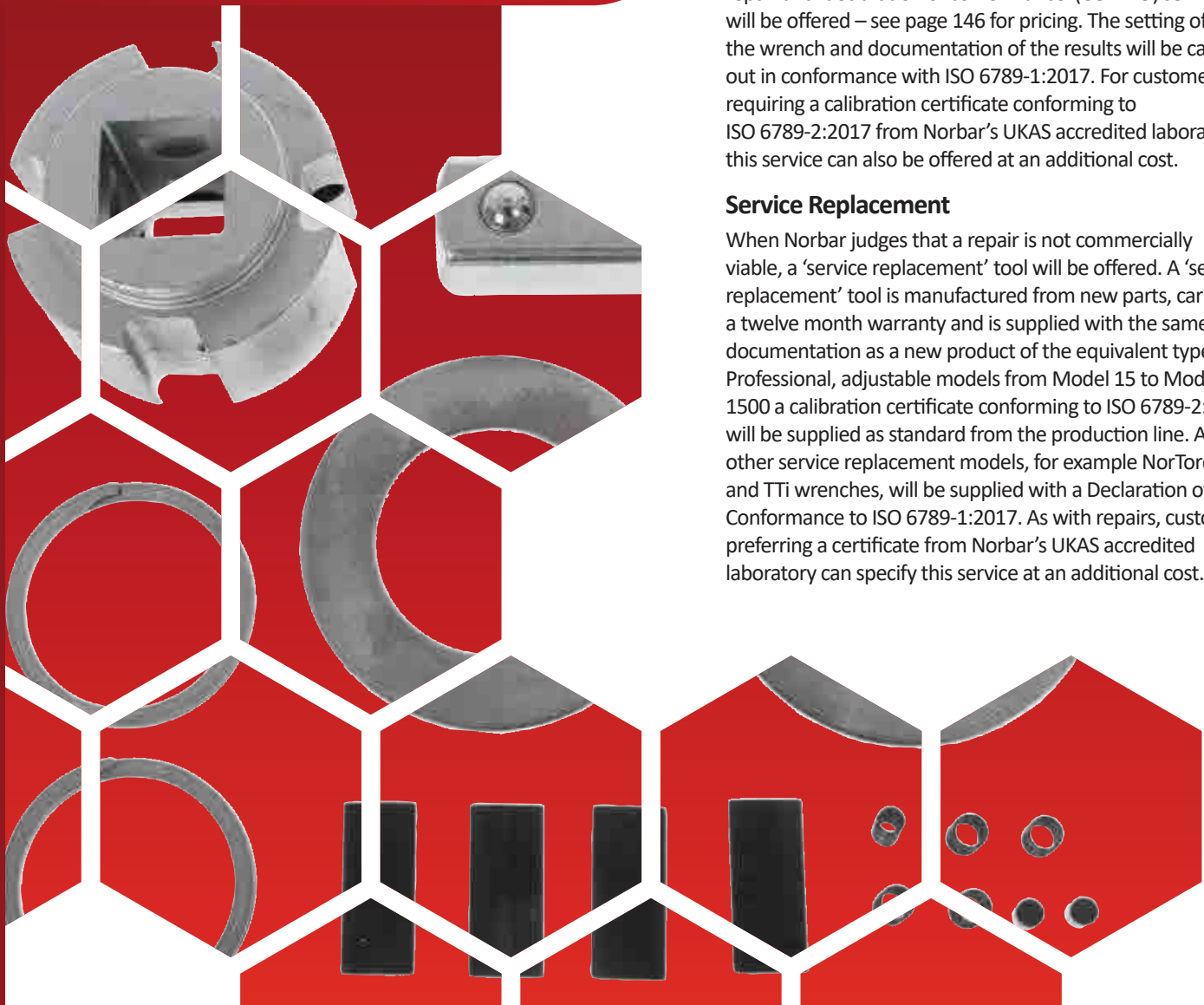

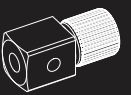

SPARES KITS

8	TORQUE SCREWDRIVER
13593.001NM	TTs Handle Repair Kit for 1.5 N-m Tool
13593.003NM	TTs Handle Repair Kit for 3.0 N-m Tool
13593.006NM	TTs Handle Repair Kit for 6.0 N-m Tool
13593.013LBI	TTs Handle Repair Kit for 13 lbf-in Tool
13593.026LBI	TTs Handle Repair Kit for 26 lbf-in Tool
13593.053LBI	TTs Handle Repair Kit for 53 lbf-in Tool
13593.P	TTs Handle Repair Kit for P Type Tool
13594	TTs Adjusting Screw & Retention Clip Repair Kit
13595	TTs Body Tube & Cam Assembly Repair Kit
13596	TTs End Knob Assembly Repair Kit
13597	TTs ¼" Blade Repair Kit
13609	TTs P Type Locking Knob Repair Kit

8	TT WRENCHES UP TO 50 N-m/35 lbf-ft
13425	¼" Ratchet Repair Kit, Mdl 20 N-m, 180 lbf-in
13426	⅜" Ratchet Repair Kit, Mdl 20 N-m, 180 lbf-in, 50 N-m, 35 lbf-ft
13427	½" Ratchet Repair Kit, Mdl 50 N-m, 35 lbf-ft
13636.020NLF	Handle Repair Kit, 20 N-m/lbf-in Scale
13636.020NM	Handle Repair Kit, 20 N-m Scale
13636.180LBI	Handle Repair Kit, 180 lbf-in Scale
13636.050NLF	Handle Repair Kit, 50 N-m/lbf-ft Scale
13636.050NM	Handle Repair Kit, 50 N-m Scale
13636.035LBF	Handle Repair Kit, 35 lbf-ft Scale
13417	Adjusting Knob Repair Kit
13637	Thrust Washer Repair Kit
11762	Rivet Repair Kit

8	TT WRENCHES 100 N-m/75 lbf-ft TO 300 N-m/250 lbf-ft
13411	Adjusting Knob Repair Kit
13415	Thrust Washer Repair Kit
13414	Rivet Repair Kit

8	TTi WRENCHES
13693	TTi20 ¼" Ratchet Lever Arm Assemblies
13694	TTi20 ⅜" Ratchet Lever Arm Assemblies
13690	TTi50 ⅜" Ratchet Lever Arm Assemblies
13691	TTi50 ½" Ratchet Lever Arm Assemblies
13212	Ratchet Repair Kit, ⅜" sq. dr., 60/100
13214	Ratchet Repair Kit, ½" sq. dr., 200
13215	Ratchet Repair Kit, ½" sq. dr., Mdl 250/300 N-m, 185/220 lbf-ft
13491	Ratchet Replacement Kit, ⅜" sq. dr., 60/100
13492	Ratchet Replacement Kit, ½" sq. dr., 50 - 200
13493	Ratchet Replacement Kit, ½" sq. dr. Mdl 250/300 N-m, 185/220 lbf-ft)

For Handle Repair Kits please see TT section to the left.

8	TTfth WRENCHES
13695	TTfth20 9 x 12 mm Female End Repair Kit
13692	TTfth50 9 x 12 mm Female End Repair Kit

8	NON-MAGNETIC RATCHET REPAIR KITS
13769	Ratchet Repair Kit for 13900, 13902, 13904 & 13906
13770	Ratchet Repair Kit for 13901, 13903, 13905 & 13907

8	MODEL 5
13123	Spares Kit Model 5 Adjustable
13124	Calibration Kit Model 5 'P' Type

8	PROFESSIONAL TORQUE WRENCHES MODELS 60 - 400 (pre March 2015)
11598	'Automotive Ratchet' Repair Kit ⅜"
	(Pro 60 & 100)
11618	'Automotive Ratchet' Repair Kit ½"
	(Pro 60 & 100)
11622	'Automotive Ratchet' Repair Kit ½" Rev
	(Pro 200 & 300)
11623	Push-Through Beta 72 Tooth Repair Kit ½"
13212	'Industrial Ratchet' Repair Kit ⅜"
	(Pro 60/100)
13213	'Industrial Ratchet' Repair Kit ½"
	(Pro 60/100)
13214	'Industrial Ratchet' Repair Kit ½" (Pro 200)
13215	'Industrial Ratchet' Repair Kit Mdl 300/330
	½" for 13047, 13049 & 13057
13216	'Industrial Ratchet' Repair Kit Pro 400 ¾"
	for 13050 & 13056
13190	Pro 400 ¾" sq. dr. to 17 mm Hex.
13235	Sq. Dr. Repair Kit ⅜" (Pro 60/100)
13236	Sq. Dr. Repair Kit ½" (Pro 60/100)
13237	Sq. Dr. Repair Kit ½" Pro 200/300/330
13157	Spares Kit Prof. Handle (post 1 st Jan 2001)
13217	Replacement Professional Handle Kit
11807	Handle Spares Kit Professional 'P' Type
11698	Calibration Kit Professional 'P' Type

8	PROFESSIONAL TORQUE WRENCHES PRO 15 - 25 SPARES KITS
15395	'Automotive Ratchet' Repair Kit, ¼" sq. dr.
15396	'Automotive Ratchet' Repair Kit, ⅜" sq. dr.
15397.K	Handle Repair Kit
15398.K	Scale Mechanism Repair Kit
15399.K	Locking Knob Repair Kit
15400.K	Thrust Washer and Screw Kit
15401.K	Spring Repair Kit



11618 'Automotive Ratchet' Repair Kit

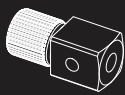

SPARES KITS

8	PROFESSIONAL TORQUE WRENCHES SPARES KITS
150100.K	Handle Repair Kit
150101.K	Scale Mechanism Repair Kit
150102.K	Locking Knob Repair Kit
150103.K	Thrust Washer and Screw Kit
150104.K	Spring Repair Kit
150105.K	½" sq. dr. Mushroom Kit
150106.K	¾" sq. dr. Mushroom Kit
150112.K	'Industrial Ratchet' Repair Kit, ¾" sq. dr. (Pro 50)
254100.PK	SKT Grub M5 x 8 LG Oval Point - Pack of 50
150113.K	'Industrial Ratchet' Repair Kit, ½" sq. dr. (Pro 100 - 200)
150114.K	'Industrial Ratchet' Repair Kit, ½" sq. dr. (Pro 300 - 340)
150115.K	'Industrial Ratchet' Repair Kit, ¾" sq. dr. (Pro 400)
11598	'Automotive Ratchet' Repair Kit ¾" sq. dr. (Pro 50 & 100)
11618	'Automotive Ratchet' Repair Kit ½" sq. dr. (Pro 50 & 100)
150111.K	'Automotive Ratchet' Repair Kit, ½" sq. dr. (Pro 200)

8	PROFESSIONAL TORQUE WRENCHES SPARES PACKS
10628.PK	Label TimeStrip - Pack of 50
10640.PK	TimeStrip Adhesive Gasket - Pack of 50
11521.PK	Shaped Washer - Pack of 20
11522.PK	End Stop - Pack of 10
15312.PK	End Cap - Pack of 25
25496.PK	SCR:SKT Grub M5 x 6 LG Oval - Pack of 50
25497.PK	SCR:SKT Grub M5 x 5 LG Dog Point - Pack of 50
254100.PK	SCR:SKT Grub M5 x 8 LG Oval Point - Pack of 50
25746.PK	M3 Dog Point Grub SCR - Pack of 50
25938.PK	Washer M4 STD.Flat - Pack of 100
26033.PK	Pivot Pin - Pack of 20
27029.PK	Steel Ball 3.8 mm Dia - Pack of 50
25351.10.PK	SHCS M4 x 10 LG - Pack of 50

8	CLICKTRONIC® TORQUE WRENCHES SPARES KITS
150104.K	Spring Repair Kit
150105.K	½" sq. dr. Mushroom Kit
150106.K	¾" sq. dr. Mushroom Kit
150107.K	Adjusting Screw and Wiper Kit
150108.K	Locking Knob Kit
150109.K	Lower Handle Kit
150110.K	Complete Handle Kit

8	CLICKTRONIC® TORQUE WRENCHES SPARES PACKS
10628.PK	Label TimeStrip - Pack of 50
10640.PK	TimeStrip Adhesive Gasket - Pack of 50
15524.PK	USB Bung - Pack of 5
39721.PK	Wiper 1 - 3 N - Pack of 5
25742.PK	M2.5 x 12 LG Torx Pan Screw - Pack of 80
25743.PK	M4 x 8 LG Torx CSK Screw - Pack of 50

8	PROFESSIONAL TORQUE WRENCHES NLD SERIES
14195	Ratchet Repair Kit Mdl 550/650 ¾"
14196	Ratchet Repair Kit Mdl 800/1000/1500 ¾"
14197	Ratchet Repair Kit Mdl 800/1000/1500 1"
14162	Ratchet Assembly Mdl 550/650
14163	Ratchet Assembly Mdl 1000
12297	Replacement Square Drive Mdl 550/650 ¾"
12299	Replacement Square Drive Mdl 550 1"
14157	Replacement Square Drive Mdl 800 - 1500 ¾"
14165	Replacement Square Drive Mdl 800 - 1500 1"
14185	Cover Kit for all Models
14218	Secondary Lever and Support Block Assy Upgrade kit for all Models pre 2004/169391
14217	Secondary Lever and Support Block Assy for all Models post 2004/169391
14220	Secondary Lever Assembly
14187	Screw Adjustable Kit for all Models
14166	Calibration Kit 'P' Type for all Models
13242	Rivet Repair Kit

8	SLIMLINE TORQUE WRENCHES
11831	Ratchet Repair Kit SLO ¼" (post Jan 2008)
11832	Ratchet Repair Kit SLO ⅜" (post Jan 2008)
11806	Spares Kit - SLO Adj Knob
11914	¾" sq.dr for SLO Fixed Head
11762	Rivet Repair Kit

8	INDUSTRIAL TORQUE WRENCHES
12307	Ratchet Repair Kit Industrial (except 6R & 6R-N)
12373	Ratchet Repair Kit (6R & 6R-N only)
12297	¾" Square Drive Assy for 3AR - 5AR & 3AR-N - 5AR-N
12299	1" Square Drive Assy for 3AR - 5AR & 3AR-N - 5AR-N
18492	1" Square Drive Assy for 6R & 6R-N
12374	1" Square Drive Repair Kit (6R & 6R-N only)
12355	Industrial Thrust Washer Spares Kit
12360	End Caps - Plastic 10 pack (Industrial)
121125	Replacement Rod/Plunger & Nut Assy. for 3AR
121126	Replacement Rod/Plunger & Nut Assy. for 4R
121127	Replacement Rod/Plunger & Nut Assy. for 4AR
121128	Replacement Rod/Plunger & Nut Assy. for 5R
121129	Replacement Rod/Plunger & Nut Assy. for 5AR
121130	Replacement Rod/Plunger & Nut Assy. for 6R
121094	5AR-N Adjusting Nut
121079	6R-N Adjusting Nut

In order for Norbar to supply the correct adjusting nut, we need to know the correct scale length for the tool being repaired. The scale length is denoted by a number on the nut being replaced and will be of the form e.g. 159/60.

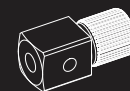

SPARES KITS

8 NORTORQUE TORQUE WRENCHES HANDLE KITS

130501.060NLF	Handle Repair Kit, 60 N-m/lbf-ft Scale
130501.060NM	Handle Repair Kit, 60 N-m Scale
130501.100NLF	Handle Repair Kit, 100 N-m/lbf-ft Scale
130501.100NM	Handle Repair Kit, 100 N-m Scale
130501.200NLF	Handle Repair Kit, 200 N-m/lbf-ft Scale
130501.200NM	Handle Repair Kit, 200 N-m Scale
130501.300NLF	Handle Repair Kit, 300 N-m/lbf-ft Scale
130501.300NM	Handle Repair Kit, 300 N-m Scale
130501.340NLF	Handle Repair Kit, 340 N-m/lbf-ft Scale
130501.340NM	Handle Repair Kit, 340 N-m Scale

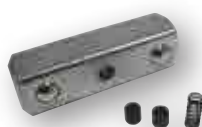

13235 Repair Kit

8 NORTORQUE TORQUE WRENCHES SQUARE DRIVE REPAIR KITS

13235	Sq. Dr. Repair Kit 3/8" (Mdl60)
13236	Sq. Dr. Repair Kit 1/2" (Mdl100)
13237	Sq. Dr. Repair Kit 1/2" (Mdl200/300/340)



13212 Repair Kit

8 NORTORQUE TORQUE WRENCHES RATCHET REPAIR KITS

13212	Ratchet Repair Kit 3/8" (Mdl60)
13213	Ratchet Repair Kit 1/2" (Mdl100)
13214	Ratchet Repair Kit 1/2" (Mdl200)
13215	Ratchet Repair Kit 1/2" (Mdl300/340)

8 NORTORQUE TORQUE WRENCHES OTHER REPAIR KITS

130500.K	Locking Knob Kit
150103.K	Thrust Washer and Screw Kit



13215 Repair Kit

8 MULTIPLIER SPARES KIT

16831	Spares Kit No. 2 Output Carrier
16836	Spares Kit No. 5 Output Carrier
16832	Spares Kit No. 7 Output Carrier
16835	Spares Kit No. 9 Output Carrier
19348	HT3-1000 N-m Retention Pin
19349	HT3-1000 N-m Cranked Reaction
19347	HT3-1000 N-m Straight Reaction
77018.1	Sq. Drive HT3 3/4" (old style)
17185	Spares Kit HT3 3/4" Sq Dr (Pre May 1993 style with shoulder screw)
17676	Sq. Drive HT3 3/4" (to fit 17218, 17220 & all other models with square drive retained by rollpin)



77018.1

17676

17185

17223	Spares Kit HT3 Carriers
17225	Spares Kit HT3 3/4" Input Gear
18365	Spares Kit 72 mm Air Motor Handle
18544	Replacement 3/4" sq. dr., ET/EBT/PTS/PTM-52 Series
18545	Replacement 1" sq. dr., ET/EBT/PTS/PTM-52 Series
18779	Replacement 3/4" sq. dr., ET/EBT/PTS/PTM-72 Series
18492	Replacement 1" sq. dr., ET/EBT/PTS/PTM-72 Series
18221	Replacement 3/4" sq. dr., PT 72 Series
18220	Replacement 1" sq. dr., PT 72 Series
19260	Spares Kit for Fwd/Rev Gearbox Knob post Feb 2011 Tools
19077	Upgrade Kit for Fwd/Rev Gearbox for PTM

8 ET/EBT/PTS/PTM-92 & ET/EBT/PTS/PTM-119 SQUARE DRIVES

18934	1" for ET/EBT/PTS/PTM-92
18935	1 1/2" for ET/EBT/PTS/PTM-92
18959	1 1/2" for ET/EBT/PTS/PTM-119

8 VANE SETS FOR PNEUTORQUE MULTIPLIERS

18631	For PTM Series (Pack of 5)
18278	For PT 72 mm Series (Pack of 6)
16218	For PT Standard Series (Pack of 6)

8 SPARES FOR LUBRO CONTROL UNIT

28911	3 m Hose*
28912	6 m Hose*
28913	Pressure Gauge
28914	Filter Element for Filter/Regulator
28915	Bowl Assembly for Filter/Regulator
28916	Bowl Assembly for Lubricator
28917	Locking Collar
28918	1/2" BSP Taper Thread Adaptor

*Other lengths of hose are available, please contact Norbar for details.



CALIBRATION SERVICES

Declaration of Conformance	146
UKAS Accredited Calibration Certification	146
Other Certification	150
Global Service	150

A calibration 'priority booking' service is available, please contact the Customer Relations Department a minimum of one month prior to the required recalibration due date.

- Tel: +44 (0)1295 753635
- Fax: +44 (0)1295 753636
- Email: service@norbar.com

CALIBRATION SERVICES

Devices sent in for UKAS accredited calibration certification will be calibrated and the 'As Found' readings recorded. The calibration will be performed to the appropriate standard as specified in our schedule of accreditation.

- a) Should the device be in specification 'As Found', a certificate will be raised and the device returned.
- b) Should the device be out of specification, but capable of adjustment, it will be adjusted, 'As Left' readings taken, and one certificate raised with 'As Found' and 'As Left' readings on it.
- c) Should the device require repair that is not covered by a combined calibration and service, we will do so where possible, after consultation with the customer.

Norbar are accredited by UKAS for torque measurements between 0.005 N·m and 108,500 N·m or the imperial equivalents. Our Schedule of Accreditation gives further details (please refer to www.norbar.com).

UKAS accredited calibration certificates are issued under the authority of the United Kingdom Accreditation Service.

Norbar can calibrate non-Norbar Torque products, please contact us with the details of your equipment.





DECLARATION OF CONFORMANCE

TORQUE WRENCH DECLARATION OF CONFORMANCE (DOC)



ONE DIRECTION

DOC1.CW	Up to 400 N·m / 300 lbf·ft
DOC2.CW	Up to 1,000 N·m / 750 lbf·ft
DOC3.CW	Up to 1,500 N·m / 1,100 lbf·ft

ONE DIRECTION & REPAIR COMBO

RCDOC1.CW	NorTorque and Professional wrenches up to 400 N·m
RCDOC2.CW	Industrial wrenches 2R - 5R & 3AR-N - 5R-N
RCDOC3.CW	Industrial wrench 5AR & 5AR-N
RCDOC4.CW	Large Professional 550 & 650 N·m
RCDOC5.CW	Large Professional 800 - 1,500 N·m

TWO DIRECTIONS

DOC1.CW+CCW	Up to 400 N·m / 300 lbf·ft
DOC2.CW+CCW	Up to 1,000 N·m / 750 lbf·ft
DOC3.CW+CCW	Up to 1,500 N·m / 1,100 lbf·ft

TWO DIRECTIONS & REPAIR COMBO

RCDOC1.CW+CCW	NorTorque and Professional wrenches up to 400 N·m
RCDOC2.CW+CCW	Industrial wrenches 2R - 5R & 3AR-N - 5R-N
RCDOC3.CW+CCW	Industrial wrench 5AR & 5AR-N
RCDOC4.CW+CCW	Large Professional 550 & 650 N·m
RCDOC5.CW+CCW	Large Professional 800 - 1,500 N·m

UKAS ACCREDITED CALIBRATION CERTIFICATION

TORQUE WRENCH, UKAS ACCREDITED CALIBRATION CERTIFICATION

On receipt an 'As Found' calibration certificate will be carried out where possible. If the results do not fall within specification the wrench will be adjusted and if the adjustment does not bring the wrench back within specification then it will either be repaired or a service replacement will be offered – see page 141 for further details. Calibration certificates are in accordance with the current standard for hand torque tools BS ISO 6789-2:2017. The certificate shows the nominal torque applied and the measured torque readings. For guidance on Norbar's procedure for wrenches sent in for repair, see page 141. If the same tool is required to be returned, i.e. if you do not want the tool to be service replaced, then this should be made clear on the purchase order which accompanies the tool.

ONE DIRECTION

TWCC1.CW	Up to 400 N·m / 300 lbf·ft
TWCC2.CW	Up to 1,000 N·m / 750 lbf·ft
TWCC3.CW	Up to 3,000 N·m / 2,200 lbf·ft

TWO DIRECTIONS

TWCC1.CW+CCW	Up to 400 N·m / 300 lbf·ft
TWCC2.CW+CCW	Up to 1,000 N·m / 750 lbf·ft
TWCC3.CW+CCW	Up to 3,000 N·m / 2,200 lbf·ft

NORTRONIC UKAS ACCREDITED CALIBRATION CERTIFICATION



ONE DIRECTION & ANGLE

NTCC1.CW	NorTronic all sizes
----------	---------------------

TWO DIRECTIONS & ANGLE

NTCC1.CW+CCW	NorTronic all sizes
--------------	---------------------

MANUAL TORQUE MULTIPLYING GEARBOXES, UKAS ACCREDITED CALIBRATION CERTIFICATION



The part numbers shown below are for Certification 'As Found',

ONE DIRECTION

HTCC1.CW	Up to 6,000 N·m / 5,000 lbf·ft
----------	--------------------------------

TWO DIRECTIONS

HTCC1.CW+CCW	Up to 6,000 N·m / 5,000 lbf·ft
--------------	--------------------------------



ELECTRONIC DEVICES

In accordance with the current standards for calibration of torque measurement devices, it is desirable to calibrate transducers with the display that is normally used. In this case the 'system' is calibrated. If it is not possible to supply the display unit, an equivalent calibrated display unit from the laboratory will be used. The calibration will then be valid for the transducer with the original display as long as the original display has been calibrated within the last 12 months.

Calibration certificates are in accordance with the current standard for torque measuring devices BS 7882:2017, and show the nominal torque applied, and the measured torque readings. Measured readings may be given in mV/V on request. Details of the standard are available on request.

It is not our intention to offer a full repair service for torque devices from other manufacturers. Where a device is in need of repair, the customer is advised to have this performed by an approved service agent or the manufacturer before submitting the device for UKAS accredited calibration. Some electronic transducer systems from other manufacturers may incur an additional calibration cost; the electronics department repair technicians will clarify this point if required. Occasionally it will be necessary to manufacture special adaptors to enable the calibration to be performed. This will of course affect the price and delivery, and will be discussed with the customer as the need arises.

CALIBRATION TO BS7882:2017 CLASS 0.1

Norbar's UKAS accredited laboratory performs standard calibrations on torque measuring devices to BS 7882:2017 class 0.2 increasing torques only. However the laboratory is able to calibrate devices to class 0.1 at the customer's request. Class 0.1 requires calibration in four different mounting positions each rotated 90° about the measurement axis. Classification to class 0.1 is dependent on the devices performance. Calibrations including a decreasing series of torques can also be provided if required. A price for these services is available on request.

This section contains combined calibration and service part numbers for Norbar products. Other manufacturers' equipment will be handled by individual quotation. Provided that the product is in serviceable condition*, we guarantee to carry out all calibration, function checks and repair work in order to bring the equipment back to its original functionality.

*Product would be regarded as unserviceable if either it or the components required for the repair are obsolete or unavailable. Serviceability also implies that the product is capable of repair without complete replacement.

Service replacements are available for some products.

ELECTRONIC TORQUE TRANSDUCERS, UKAS ACCREDITED CALIBRATION CERTIFICATION (WITH SQUARE DRIVE, FLANGE MOUNTED & PRE 2004 ROTARY)



The part numbers shown below are for Combined Calibration and Service, 'As Found' and 'As Left'

ONE DIRECTION

TDCCS1.CW	Up to 1,500 N·m / 1,000 lbf-ft
TDCCS5.CW®	From 1,501 to 7,000 N·m / 1,001 - 5,000 lbf-ft
TDCCS3.CW*	Square/Splined Drive From 7,001 to 100,000 N·m / 5,001 to 100,000 lbf-ft
TDCCS4.CW*	Flange Drive From 7,001 to 100,000 N·m / 5,001 to 100,000 lbf-ft
ADDCALPOINTS.CCS	Additional calibration steps below 10% of rated capacity to 2% for transducers up to 7,000 N·m (5,000 lbf-ft)

TWO DIRECTIONS

TDCCS1.CW+CCW	Up to 1,500 N·m / 1,000 lbf-ft
TDCCS5.CW+CCW®	From 1,501 to 7,000 N·m / 1,001 - 5,000 lbf-ft
TDCCS3.CW+CCW*	Square/Splined Drive From 7,001 to 100,000 N·m / 5,001 to 100,000 lbf-ft
TDCCS4.CW+CCW*	Flange Drive From 7,001 to 100,000 N·m / 5,001 to 100,000 lbf-ft

@ UKAS accredited calibration up to 6,000 N·m. A non-accredited value at 7,000 N·m is extrapolated and provided for reference only.

+ UKAS accredited calibration up to 80,000 lbf-ft. A non-accredited value at 100,000 lbf-ft is extrapolated and provided for reference only.

For part numbers TDCCS3.CW and TDCCS4.CW, static transducers with 2½" square drives and annular transducers to fit HT/PT 9 & HT/PT 11, a secondary calibration to extend the range below 10% of the rated capacity may be ordered using part number TDCCS5.CW

For part numbers TDCCS3.CW+CCW and TDCCS4.CW+CCW, static transducers with 2½" square drives and annular transducers to fit HT/PT 9 & HT/PT 11, a secondary calibration to extend the range below 10% of the rated capacity may be ordered using part number TDCCS5.CW+CCW



UKAS ACCREDITED CALIBRATION CERTIFICATION

Calibration details

ROTARY TRANSDUCERS (2004 ONWARDS), UKAS ACCREDITED CALIBRATION CERTIFICATION (PART CODE 50708.XXX-50724.XXX)



The part numbers shown below are for combined calibration and service, 'As Found' and 'As Left'

ONE DIRECTION

TDCCS2.CW	Up to 1,500 N·m / 1,000 lbf-ft
-----------	--------------------------------

TWO DIRECTIONS

TDCCS2.CW+CCW	Up to 1,500 N·m / 1,000 lbf-ft
---------------	--------------------------------

TRUCHECK VERSIONS 1 & 2



The part numbers shown below are for combined calibration and service, 'As Found' and 'As Left'

ONE DIRECTION

TCCCS1.CW	TruCheck versions 1 & 2 All Sizes up to 1,500 N·m (UKAS Accredited Calibration Certification)
TCCCS3.CW	TruCheck versions 1 & 2 All Sizes over 1,500 N·m (UKAS Accredited Calibration Certification)
TCCCS2.CW*	TruCheck versions 1 & 2 All Sizes up to 1,500 N·m
TCCCS4.CW*	TruCheck versions 1 & 2 All Sizes over 1,500 N·m

TWO DIRECTIONS

TCCCS1.CW+CCW	TruCheck versions 1 & 2 All Sizes up to 1,500 N·m (UKAS Accredited Calibration Certification)
TCCCS3.CW+CCW	TruCheck versions 1 & 2 All Sizes over 1,500 N·m (UKAS Accredited Calibration Certification)

*Issued with traceable certification.

PRO-TEST, UKAS ACCREDITED CALIBRATION CERTIFICATION



The part numbers shown below are for combined calibration and service, 'As Found' and 'As Left'

ONE DIRECTION

PROCCS.CW	Pro-Test All sizes
-----------	--------------------

TWO DIRECTIONS

PROCCS.CW+CCW	Pro-Test All Sizes
---------------	--------------------

PRO-LOG, TTT, T-BOX, T-BOX XL, T-BOX 2 & TTL-HE, UKAS ACCREDITED CALIBRATION CERTIFICATION



The part numbers shown below are for combined calibration and service, 'As Found' and 'As Left'

ONE DIRECTION

INSTCCS3.CW	Pro-Log or TTT
-------------	----------------

TWO DIRECTIONS

INSTCCS3.CW+CCW	Pro-Log or TTT
INSTCCS4.CW+CCW	TTL-HE, T-Box, T-Box XL or TWC Auto Control Box
INSTCCS5.CW+CCW	T-Box 2

TST, UKAS ACCREDITED CALIBRATION CERTIFICATION



The part numbers shown below are for combined calibration and service, 'As Found' and 'As Left' This includes both an instrument and system calibration

ONE DIRECTION

TSTCCS.CW	TST
-----------	-----

TWO DIRECTIONS

TSTCCS.CW+CCW	TST
---------------	-----

Section with combined calibration & service ends here

CALIBRATION BEAMS & WEIGHTS, UKAS ACCREDITED CALIBRATION CERTIFICATION



The part numbers shown below are for Length Certification, 'As Found' and 'As Left'

CBLC1	Disc or Beam up to 150 N·m / 100 lbf-ft
CBLC2	Disc or Beam up to 1,500 N·m / 1,000 lbf-ft
CBLC3*	Disc or Beam up to 6,800 N·m / 5,000 lbf-ft
WEIGHT.CC1	Calibration of Weights up to 25 kgf / 245 N / 55 lbf

* The part number shown is for length certification, 'As Found'



UKAS ACCREDITED CALIBRATION CERTIFICATION



MECHANICAL TORQUE TESTING DEVICES, UKAS ACCREDITED CALIBRATION CERTIFICATION



The part numbers shown below are for combined calibration and service, 'As Found' and 'As Left'

ONE DIRECTION

MCCS1.CW | Up to 5,000 N·m / 5,000 lbf-ft

TWO DIRECTIONS

MCCS1.CW+CCW | Up to 5,000 N·m / 5,000 lbf-ft

TWA, UKAS ACCREDITED CALIBRATION CERTIFICATION



The part numbers shown below are for Combined Calibration and Service, 'As Found' and 'As Left'

ONE DIRECTION

TWACCS.CW | TWA All Sizes

TWO DIRECTIONS

TWACCS.CW+CCW | TWA All Sizes

ETS, UKAS ACCREDITED CALIBRATION CERTIFICATION



The part numbers shown below are for combined calibration and service, 'As Found' and 'As Left'

INSTCCS1.CW | ETS

DTS, UKAS ACCREDITED CALIBRATION CERTIFICATION



ONE DIRECTION

DTSCCS1.CW®	DTS up to 7,000 N·m or 5,000 lbf-ft
DTSCCS2.CW*	DTS from 7,001 to 100,000 N·m / 5,001 to 100,000 lbf-ft Square and Spline drive
DTSCCS3.CW*	DTS from 7,001 to 100,000 N·m / 5,001 to 100,000 lbf-ft Flange drive

TWO DIRECTIONS

DTSCCS1.CW+CCW®	DTS up to 7,000 N·m or 5,000 lbf-ft
DTSCCS2.CW+CCW*	DTS from 7,001 to 100,000 N·m / 5,001 to 100,000 lbf-ft Square and Spline drive
DTSCCS3.CW+CCW*	DTS from 7,001 to 100,000 N·m / 5,001 to 100,000 lbf-ft Flange drive

- @ UKAS accredited calibration up to 6,000 N·m. A non-accredited value at 7,000 N·m is extrapolated and provided for reference only.
- + UKAS accredited calibration up to 80,000 lbf-ft. A non-accredited value at 100,000 lbf-ft is extrapolated and provided for reference only.

ETTA, UKAS ACCREDITED CALIBRATION CERTIFICATION



The part numbers shown below are for combined calibration and service, 'As Found' and 'As Left'

ETTACCS.CW | ETTA

GENERAL DEVICES, UKAS ACCREDITED CALIBRATION CERTIFICATION

EMCC | Mechanical Enclosure Meter Calibration (CW + CCW)



OTHER CERTIFICATION

EVOTORQUE AND PNEUTORQUE CERTIFICATES



These devices are outside the scheduled accreditation issued by UKAS.

HTCERT	Compact Series Calibration
PTCERT	PneuTorque Calibration
PTICEC	PTM IC/EC Certificate of air pressure vs torque
ETCERT	EvoTorque 1, 2 & EBT Certificate of torque and angle

USM CERTIFICATES



These devices are outside the scheduled accreditation issued by UKAS.

USMCC	Ultrasonic Stress Meter certificate of calibration
-------	----------------------------------------------------

GENERAL DEVICES

These devices are outside the scheduled accreditation issued by UKAS.

Weight Set Certificates accredited by UKAS or other certified bodies

ETSDPFT	ETS Data Printer. Function Test
ETSBPUFT	ETS Battery Power Unit. Function Test
FWSUFT	ETS or ETTA 5 Way Switch Unit. Function Test
TWSUFT	ETS or ETTA 2 Way Switch Unit. Function Test

TRANSDUCER CONVERSIONS

SQ8888	ETS Transducer conversion to Smart Transducer (does not include calibration)
SQ2005	ETTA Transducer conversion to Smart Transducer (does not include calibration)

GLOBAL SERVICE

Norbar is the only torque equipment manufacturer capable of offering tool and instrument calibration services to the original factory standard on four continents.



NORBAR TORQUE TOOLS LTD
Wildmere Road, Banbury,
Oxfordshire, OX16 3JU
UNITED KINGDOM
Tel + 44 (0)1295 753600
Email sales@norbar.com



NORBAR TORQUE TOOLS
45-47 Raglan Avenue,
Edwardstown, SA 5039
AUSTRALIA
Tel + 61 (0)8 8292 9777
Email norbar@norbar.com.au



NORBAR TORQUE TOOLS INC
36400 Biltmore Place,
Willoughby, Ohio 44094
USA
Tel + 1 866 667 2272
Email inquiry@norbar.us



NVLAP Lab Code 200596-0



NORBAR TORQUE TOOLS
c/o Snap-on Tools Singapore PTE LTD
25 Tagore Lane #01-02
SINGAPORE 787 602
Tel + 65 6841 1371
Email enquiries@norbar.sg



NORBAR TORQUE TOOLS (SHANGHAI) LTD
7/F, Building 91, No. 1122,
Qinzhou North Road
Xuhui District, Shanghai
CHINA 200233
Tel + 86 21 6145 0368
Email sales@norbar.com.cn



NORBAR TORQUE TOOLS INDIA PVT. LTD
Plot No A – 168 Khairne Industrial Area
Thane Belapur Road
Mahape Navi Mumbai – 400 709
INDIA
Tel + 91 22 2778 8480
Email enquiry@norbar.in



Accredited laboratories in Australia, USA, Singapore, China and India operate the same equipment and procedures as the UKAS accredited laboratory within our headquarters in the UK.



TERMS & CONDITIONS - SEPTEMBER 2021

1. INTERPRETATION AND APPLICATION OF TERMS

1.1 In these Conditions the following words have the following meanings:

“Contract”	means the contract between Norbar and the Customer for the sale and purchase of the Goods and/or Services, incorporating these Conditions, the Order and the Order Acknowledgement;
“Customer”	means the person(s), firm, company, entity or organisation who purchases Goods and/or Services from Norbar;
“Customer Equipment”	means equipment belonging to the Customer which is the subject of Services to be carried out under a Contract or which are to be incorporated into any Goods;
“Delivery Point”	means the address within the UK mainland which is notified to Norbar as the place for delivery of the Goods and/or Customer Equipment;
“Engineer to Order Goods”	means any non-standard Goods specifically designed, modified and/or made for the Customer or to the Customer’s specification;
“Goods”	means the goods set out in the Order to be supplied by Norbar to the Customer (including any part or parts of them and, if applicable, any Customer Equipment);
“Norbar”	means Norbar Torque Tools Limited (380480), whose registered office address is at Wildmere Road, Banbury, Oxon, OX16 3JU;
“Order”	means the order for the Goods and/or Services placed on Norbar by the Customer;
“Order Acknowledgement”	means the acknowledgement of Order issued by Norbar to the Customer;
“Services”	means the services set out in the Order to be performed by Norbar for the Customer.

- 1.2 Subject to any variation under Condition 1.4 the Contract will be on these Conditions, the Order and the Order Acknowledgement to the exclusion of all other terms and conditions. They supersede any previously issued terms and conditions of supply. If there is any discrepancy between these Conditions and the Order Acknowledgement, the latter will prevail to the extent necessary to resolve the inconsistency.
- 1.3 No terms or conditions endorsed upon, delivered with or contained in the Customer’s Order, confirmation of order, specification or other document will form part of the Contract.
- 1.4 These Conditions apply to all of Norbar’s sales and any variation to these Conditions and any representations about the Goods and/or Services will have no effect unless expressly agreed in writing and signed by an authorised representative of Norbar. The Customer acknowledges that it has not relied on and will have no remedy in respect of any statement, promise or representation made or given by or on behalf of Norbar which is not set out in the Contract. Nothing in this Condition will exclude or limit Norbar’s liability for fraudulent misrepresentation.
- 1.5 Each Order or acceptance of a quotation for Goods or Services submitted by the Customer to Norbar will be deemed to be an offer by the Customer to purchase Goods and/or Services subject to these Conditions. No Order will be deemed to be accepted by Norbar until a written Order Acknowledgement is issued by Norbar at which point the Contract shall come into existence.
- 1.6 Any quotation is given on the basis that no Contract will come into existence until Norbar despatches an Order Acknowledgement. Any quotation is valid for a period of 30 days only from its date, provided that Norbar has not previously withdrawn or amended it.

2 DESCRIPTION

- 2.1 The description of the Goods will be as set out in Norbar’s catalogue or other published specification current at the time that the relevant Order is accepted by Norbar or, in the case of Services and Engineer to Order Goods, as specified in the relevant quotation or Order Acknowledgement. If there is any inconsistency between the published specification, the quotation and the Order Acknowledgement, the Order Acknowledgement will take precedence over the quotation which will take precedence over the published specification to the extent necessary to resolve the inconsistency.
- 2.2 Norbar reserves the right to make any changes to the specification of the Goods (including Engineer to Order Goods) and/or Services which are required to conform with any applicable statutory or regulatory requirements or which do not materially affect their quality or performance. The Customer will not be permitted to reject Goods and/or Services and Norbar will have no liability to the Customer in respect of any failure of the Goods and/or Services to comply with any specification in these circumstances.
- 2.3 The Customer acknowledges that all intellectual property rights in the Goods (including Engineer to Order Goods) and in any novel combinations or applications of the Goods (whether as a kit, system or otherwise) or which arise in the course of conducting the Services belong solely to Norbar and, to the extent that any such rights do not automatically vest in Norbar by operation of law, hereby assigns and agrees to assign to Norbar all such rights. The Customer will take any action and execute any document reasonably required by Norbar to give full effect to this Condition.

3 DELIVERY

- 3.1 In the case of sales of Goods within the UK mainland, delivery will take place:
- if the Goods are to be collected, on delivery to the Customer or to the Customer’s named carrier at Norbar’s premises at Wildmere Road, Banbury, Oxon OX16 3JU; and
 - in all other cases, on delivery to the Delivery Point.
- In the case of sales outside the UK mainland (including non-mainland UK) sales will be delivered Ex Works Norbar’s premises at Wildmere Road, Banbury, Oxon OX16 3JU (INCOTERMS 2020 edition), except where otherwise agreed in writing.
- 3.2 All Services will be performed at Norbar’s premises at Wildmere Road, Banbury, Oxon OX16 3JU unless otherwise agreed in writing and the Services will be deemed to be performed on completion of the performance of the Services as specified in the Order Acknowledgement.
- 3.3 Any dates specified by Norbar for delivery of the Goods or performance of the Services are intended to be an estimate only and time for delivery will not be made of the essence by notice. If no dates are so specified, delivery will be within a reasonable time. The Goods and/or Services may be delivered by instalments.
- 3.4 Norbar will have no liability for any delay in the delivery of the Goods or performance of the Services to the extent that it is caused by any omission or delay on behalf of the Customer, including any delay in the provision of any Customer Equipment.

- 3.5 If for any reason the Customer will not accept delivery of any of the Goods when they are ready for delivery, or Norbar is unable to deliver the Goods on time because the Customer has not provided appropriate instructions, documents, licences or authorisations then, without prejudice to any other right or remedy available to Norbar:
- risk in the Goods will pass to the Customer;
 - the Goods will be deemed to have been delivered; and
 - Norbar may store the Goods until delivery whereupon the Customer will be liable for all related costs and expenses (including, without limitation, storage and insurance).
- 3.6 The Customer has no right to cancel an Order once an Order Acknowledgement has been issued, but Norbar may, at its discretion, accept cancellation of any Order or returns of Goods ordered in error or no longer required, subject to the payment of a handling charge of 15% of the order value (excluding VAT), except that:
- Production ‘P’ type wrenches may not be cancelled or returned;
 - Goods supplied with a UKAS accredited or traceable calibration certificate will be subject to a recalibration charge in addition to the handling charge;
 - Engineer to Order Goods may be charged for up to 100% of full price.
- Goods returned for credit will only be accepted if they are returned in the original packaging, in a new, unused condition, carriage paid within 30 days after the despatch date.

4 NON DELIVERY

- 4.1 The quantity of any consignment of Goods as recorded by Norbar upon despatch from Norbar’s place of business will be conclusive evidence of the quantity received by the Customer on delivery unless the Customer can provide conclusive evidence proving the contrary.
- 4.2 Norbar will not be liable for any non delivery of Goods (even if caused by Norbar’s negligence) unless written notice is given to Norbar within 14 days of the date when the Goods would, in the ordinary course of events, have been received.
- 4.3 Any liability of Norbar for non delivery of the Goods will be limited to replacing the Goods within a reasonable time or issuing a credit note at the pro rata Contract rate against any invoice raised for such Goods.

5 RISK/TITLE

- 5.1 The Goods are at the risk of the Customer from the time of delivery.
- 5.2 Ownership of the Goods will not pass to the Customer until Norbar has received in full (in cash or cleared funds) all sums due to it in respect of the Goods and all other sums which are or which become due to Norbar from the Customer on any account.
- 5.3 Until ownership of the Goods has passed to the Customer, the Customer will hold all Goods on a fiduciary basis as Norbar’s bailee and Norbar will be entitled at any time:
- to require (at no cost to Norbar) that the Goods are stored separately and clearly marked in such a way that they will readily be seen to be the property of Norbar; and/or
 - to require the Customer to deliver up the Goods or any part of them to Norbar and if the Customer refuses to do so, to immediately repossess them; and/or
 - to enter any premises or vehicle (by its employees or agents and in the case of premises, with or without vehicles) where Goods still owned by Norbar are stored or reasonably thought to be stored in order to inspect and/or repossess them.
- 5.4 Norbar will be entitled to recover payment for the Goods ordered notwithstanding that ownership of the Goods has not passed from Norbar.
- 5.5 The Customer may resell the Goods before ownership has passed to it providing that any such sale is made in the ordinary course of its business at full market value and the Customer is not aware that an event specified in Condition 5.6(a) has occurred or is likely to occur.
- 5.6 Until ownership of the Goods has passed to the Customer, the Customer’s right to possession of the Goods will terminate immediately if:
- the Customer is made bankrupt or petitions for its own bankruptcy, or has a receiver, administrative receiver or administrator appointed over all or any of its assets or undertaking or, other than for the purposes of a solvent amalgamation or reconstruction, enters into liquidation, enters into any composition or arrangement with or for the benefit of its creditors or ceases to carry on business; or
 - the Customer fails to observe or perform any of its obligations under the Contract or any other contract between Norbar and the Customer; or
 - the Customer encumbers or in any way charges any of the Goods.
- 5.7 Ownership of all Customer Equipment will remain the property of the Customer throughout the provision of the Services. Subject to Condition 6.2, Norbar will take reasonable care to safeguard the Customer Equipment and no less care than it takes to safeguard its own similar property.
- 5.8 On termination of the Contract for any reason, Norbar’s rights under this Condition 5 will remain in effect.

6 PRICE AND PAYMENT

- 6.1 Unless otherwise agreed by Norbar in writing the price for the Goods and/or Services will be the price set out in Norbar’s price list current as at the date of delivery of the Goods or performance of the Services or will be as set out in any quotation provided by Norbar.
- 6.2 The price given in the current Norbar price list for calibration and repair services or in any quotation for such Services is subject to the returned Customer Equipment being of serviceable condition. If the Customer Equipment is not of serviceable condition or is out of specification and cannot be adjusted or is uneconomic to repair, either a new quotation will be provided or a service replacement tool will be offered to the Customer. If the Customer does not accept the revised quotation or service replacement within 30 days, Norbar will re-quote, revising the costs as necessary. If after a further 30 days instructions have still not been received, Norbar may (at its option) either return the Customer Equipment and invoice for costs incurred or dispose of the Customer Equipment.
- 6.3 The price for the Goods and/or Services will be exclusive of any value added tax which the Customer will pay in addition when it is due to pay for the Goods and/or Services. The price for Goods and Services includes the cost of delivery (or return of Customer Equipment in the case of Services) if the order (i) is for delivery on Monday to Friday (inclusive) within the UK mainland to the Customer’s usual Delivery Point using Norbar’s usual delivery method and (ii) has a value of over £100.00 (excluding VAT). If delivery is to Northern Ireland, the price for Goods and Services includes the cost of delivery (or return of Customer Equipment in the case of Services) if the order (i)



TERMS & CONDITIONS - SEPTEMBER 2021

- is for delivery on Monday to Friday (inclusive) to the Customer's usual Delivery Point using Norbar's usual delivery method and (ii) has a value of over £300.00 (excluding VAT). In all other cases, the cost of delivery of Goods or return of Customer Equipment will be charged in addition and will be due for payment at the same time as payment for the Goods is due.
- 6.4 If the Customer holds an account with Norbar, payment of the price for the Goods and/or Services is due within the agreed payment terms for that account. If any amount payable is not made within 30 days after the due date in accordance with the terms of the account, Norbar may withdraw credit facilities. If the Customer does not have an account with Norbar, or if credit facilities have been withdrawn from the Customer, payment is due either at the time the Order is placed or in accordance with any payment schedule set out in the quotation and may be tendered by credit card or bank transfer. In all cases, payment must be in pounds sterling (except where otherwise agreed in writing).
- 6.5 Time for payment will be of the essence.
- 6.6 No payment will be deemed to have been received until Norbar has received cleared funds.
- 6.7 All payments payable to Norbar under the Contract will become due immediately upon termination of this Contract notwithstanding any other Condition of the Contract or any other arrangement or agreement between the parties.
- 6.8 The Customer will make all payments due under the Contract without any deduction whether by way of set-off, counterclaim, discount, abatement or otherwise unless the Customer has a valid court order requiring an amount equal to such deduction to be paid by Norbar to the Customer.
- 6.9 If the Customer fails to pay Norbar any sum due pursuant to the Contract the Customer will be liable to pay interest to Norbar on such sum from the due date for payment at the annual rate of 4% above the base lending rate from time to time of Barclay's Bank plc, accruing on a daily basis until payment is made, whether before or after any judgment.
- ### 7. WARRANTY AND LIABILITY
- 7.1 Norbar warrants that, subject to the other provisions of these Conditions upon delivery, and for a period of 12 months after the date of delivery, the Goods will:
- be of satisfactory quality within the meaning of the Sale of Goods Act 1979; and
 - comply in all material respects with the specification for them as set out in Norbar's catalogue or other published specification current at the time that the order for the Goods was accepted by Norbar.
- 7.2 Norbar warrants that, subject to the other provisions of these Conditions all Services will:
- be supplied with reasonable skill and care within the meaning of the Supply of Goods and Services Act 1982; and
 - conform in all material respects with the specification for them as set out in Norbar's catalogue or other published specification current at the time the order for the Services was accepted by Norbar (unless specifically varied in the quotation or Order Acknowledgement).
- 7.3 Norbar will not be liable for a breach of any of the warranties in Condition 7.1 unless:
- the Customer gives written notice of the defect to Norbar within 14 days of the time when the Customer discovers or ought to have discovered the defect; and
 - the Customer returns the defective Goods properly packed, carriage paid to Norbar's premises at the address given in Condition 1.1 or otherwise specified by Norbar.
- 7.4 Norbar will not be liable for a breach of the warranties in Condition 7.1 if:
- the Customer makes any further use of the Goods after giving notice of any defect; or
 - the Goods have been misused, mishandled, overloaded, amended, modified or repaired in any way by the Customer or its customers, or used for any purpose other than that for which they were designed; or
 - the defect is due to fair wear and tear or arises because the Goods have been subject to excessive use or used in an environment for which they were not designed;
 - the defect is due to the incorporation of any Customer Equipment; or
 - the Goods differ from their specification as a result of changes made to ensure they comply with applicable statutory or regulatory requirements; or
 - the Customer or its customer has failed to follow Norbar's oral or written instructions as to the storage, installation, commissioning, use, repair, calibration or maintenance of the Goods or the recommendations set out in any national or international standard applicable to the Goods or (if there are no applicable instructions or standards) good trade or engineering practice.
- 7.5 Norbar will not be liable for a breach of the warranties in Condition 7.2 unless:
- the Customer gives written notice to Norbar identifying which Services are defective in sufficient detail within 14 days of the time when the Customer discovers or ought to have discovered the defect; and
 - if the claim relates to Customer Equipment, Norbar is given a reasonable opportunity to examine the Customer Equipment and to assess the claim of defective Services,
- 7.6 Subject to Conditions 7.3 and 7.4, if any of the Goods do not conform with any of the warranties in Condition 7.1, Norbar will at its option repair or replace such Goods (or the defective part of them) or refund the price of such Goods at the pro rata Contract rate. The provisions of these Conditions will apply to any Goods that are remedied or replaced.
- 7.7 Subject to Condition 7.5 if any of the Services do not conform with any of warranties in Condition 7.2, Norbar will at its option remedy, re-perform or refund the Services that do not comply at the pro rata Contract rate. The provisions of these Conditions will apply to any Services that are remedied or re-performed for a period of 90 days with effect from the date of performance of the remedied or re-performed Services. If any repair of Customer Equipment fails within 90 days after the date on which it was returned to the Customer by Norbar, Norbar will at its option remedy, re-perform or refund the Services that do not comply at the pro rata Contract rate.
- 7.8 If Norbar complies with Condition 7.6 or 7.7 (as applicable), it will have no further liability for a breach of any of the warranties in Condition 7.1 or 7.2 in respect of such Goods and/or Services.
- 7.9 Except as provided in Conditions 7.1 and 7.2, Norbar makes no representation or warranty, whether express or implied, as to the quality or fitness for purpose of the Goods or Services and all warranties, Conditions and other terms which may be implied by statute or common law are, to the fullest extent permitted by law, excluded from the Contract.

- 7.10 Nothing in this Contract excludes or limits the liability of Norbar for:
- death or personal injury caused by Norbar's negligence; or
 - defective products under the Consumer Protection Act 1987; or
 - for fraud or fraudulent misrepresentation; or
 - any matter for which it would be unlawful for Norbar to exclude or restrict liability.

THE CUSTOMER'S ATTENTION IS DRAWN TO THE PROVISIONS OF CONDITION 7.11

- 7.11 Subject to Condition 7.10:
- Norbar's total liability in contract, tort (including negligence or breach of statutory duty), misrepresentation, restitution or otherwise arising in connection with the performance or contemplated performance of this Contract will be limited to the price of the Goods and/or Services; and
 - Norbar will not in any event be liable to the Customer for any loss of profit, loss of business or depletion of goodwill or loss of data, in each case whether direct, indirect or consequential, or any claims for consequential compensation whatsoever (howsoever caused) which arise out of or in connection with this Contract.
- 7.12 The Customer acknowledges that the price of the Goods and/or Services has been calculated on the basis that Norbar excludes and limits its liability in accordance with Condition 7.11.
- 7.13 Where the Goods and/or Services are sold under a consumer transaction the statutory rights of the Customer are not affected by these Conditions.

8. FORCE MAJEURE

Norbar reserves the right to defer the date of delivery or to cancel the Contract or reduce the volume of the Goods or Services ordered by the Customer (without liability to the Customer) if it is prevented from or delayed in the carrying on of its business due to circumstances beyond the reasonable control of Norbar including, without limitation, acts of God, governmental actions, war or national emergency, riot, civil commotion, fire, explosion, flood, epidemic, pandemic, lock-outs, strikes or other labour disputes (whether or not relating to either party's workforce), or restraints or delays affecting carriers or inability or delay in obtaining supplies of adequate or suitable materials or components.

9. NOTICES

Any notice to be given under this Contract will be in writing and will be sent by first class mail or courier within the UK, or by courier if outside the UK; in the case of Norbar to the address set out in Condition 1.1 and in the case of the Customer to the Delivery Point or such other address as the Customer may from time to time notify to Norbar for this purpose in accordance with this Condition. Notices sent as above will be deemed to have been received three working days after the date of posting (in the case of mail within the UK), and at the time of delivery in the case of courier delivery.

10. ANTI-BRIBERY AND EXPORT CONTROL

- 10.1 Both Norbar and the Customer will comply at all times with all applicable laws, regulations, orders, judicial decision, conventions and international financial institution rules regarding corruption, bribery, ethical business conduct, money laundering, political contributions, gifts and gratuities, or lawful expenses to public officials and private persons, agency relationships, commissions, lobbying, books and records and financial controls, including without limitation, the Foreign Corrupt Practices Act, a law of the United States of America and the United Kingdom Bribery Act, a law of the United Kingdom (collectively "Anti-Corruption Laws"), and will maintain in place its own policies and procedures to ensure compliance with Anti-Corruption Laws and will enforce them where appropriate.
- 10.2 The Customer will immediately notify Norbar (in writing) if a public official becomes an officer or employee of the Customer or acquires a direct or indirect interest in the Customer (and the Customer warrants that it has no foreign public officials as officers, employees or direct or indirect owners at the date of this Agreement).
- 10.3 The Customer acknowledges that some Goods may be subject to UK export control laws and may be subject to export or import regulations in other countries. The Customer will comply fully with all applicable domestic and foreign laws and regulations in connection with the sale and use of the Goods and will, at the request of Norbar, provide such information and/or documents as Norbar may reasonably request as to the intended final destination of and use for the Goods.
- 10.4 Norbar may cancel any order (even after it has been accepted) with no liability to the Customer if Norbar is not satisfied by the information provided in accordance with Condition 10.3 or otherwise has reason to believe or be concerned that any applicable export control regulations or Anti-Corruption Laws may be breached.

11. GENERAL

- 11.1 The parties to the Contract do not intend that any term of the Contract will be enforceable by virtue of the Contracts (Rights of Third Parties) Act 1999 by any person that is not a party to it, except that any Affiliate of Norbar may directly enforce any term of the Contract where "Affiliate" means any entity that directly or indirectly Controls, is Controlled by or is under common control with Norbar and "Control" means ownership of more than 50% of the issued share capital of a company.
- 11.2 Each right or remedy of Norbar under the Contract is without prejudice to any other right or remedy of Norbar whether under the Contract or not.
- 11.3 If any provision of the Contract is found by any court, tribunal or administrative body of competent jurisdiction to be wholly or partly illegal, invalid, void, voidable or unenforceable it will to the extent of such illegality, invalidity, voidness, voidability or unenforceability be deemed severable and the remaining provisions of the Contract and the remainder of such provision will continue in full force and effect.
- 11.4 The Customer will not be entitled to assign the Contract or any part of it without the prior written consent of Norbar. Norbar may assign the Contract or any part of it or sub-contract any or all of its obligations under the Contract to any person, firm or company.
- 11.5 Failure or delay by Norbar in enforcing or partially enforcing any provision of the Contract will not be construed as a waiver of any of its rights under the Contract.
- 11.6 Any waiver by Norbar of any breach of, or any default under, any provision of the Contract by the Customer will not be deemed a waiver of any subsequent breach or default and will in no way affect the other terms of the Contract.
- 11.7 The formation, existence, construction, performance, validity and all aspects of the Contract will be governed by English law and the parties submit to the non-exclusive jurisdiction of the English courts.

2022 NORBAR SHUTDOWN PERIODS

THE FACTORY WILL BE CLOSED ON THE FOLLOWING DATES (INCLUSIVE)

Monday 3 rd January - New Year's Day
Friday 15 th April to Monday 18 th April - Easter Bank Holiday
Monday 2 nd May - Early May Bank Holiday
Thursday 2 nd June - Spring Bank Holiday
Friday 3 rd June - Platinum Jubilee Bank Holiday
Monday 29 th August - Summer Bank Holiday
Monday 26 th December to Tuesday 3 rd January 2023 - Christmas Shutdown

NORBAR PROMOTIONAL MATERIAL

CATALOGUES & LEAFLETS

07571	NorTorque® Sales Leaflet
07563	Professional Torque Wrench Sales Leaflet
07594	Industrial Torque Wrench- New Generation Sales Leaflet
07606	ProTronic® Sales Leaflet
07607	ProTronic® Plus Sales Leaflet
07436	NorTronic® Sales Leaflet
07579	HandTorque® HT3-1000 Sales Leaflet
07570	EvoTorque®2 Sales Leaflet
07591	EvoTorque® Battery Tool Sales Leaflet
07581	PneuTorque® PTS™ Sales Leaflet
07585	Right Angle Gearbox Sales Leaflet
07597	TruCheck™ 2 Sales Leaflet
07598	T-Box™ 2 Sales Leaflet
07589	TWC Sales Leaflet
07512	Aerospace Leaflet
07515	Energy Generation Leaflet
07510	Oil & Gas Leaflet

PROMOTIONAL ITEMS

07532	Norbar Torque Wrench Display Board Contact Norbar for slat wall adaptors
07539	Norbar Branded Pen
07551	Norbar Branded Pocket Notepad
07555	Norbar Branded Baseball Cap
07587	Norbar Branded USB Stick
07574	Norbar Branded 2 Ring White Ring Binder
07576	Norbar Branded Screen Saver Cloth / Mouse Mat

NORBAR PRODUCT PORTFOLIO



Torque Screwdrivers



Torque Wrenches



Electronic Torque Wrenches



Manual Torque Multipliers



Pneumatic Torque Tools



Electronic Torque Tools



Battery Torque Tools



Torque Measurement Instruments



Torque Transducers



Calibration Services

NORBAR SOCIAL MEDIA



@voiceoftorque



www.norbar.com/news-events/blog



Norbar Torque Tools Ltd



Norbar Torque Tools



Norbar Torque



Norbar Torque Tools Ltd

CUSTOMER RELATIONS

OFFICE OPENING HOURS

Monday - Thursday	07:30 - 17:30
Friday	07:30 - 16:15

CONTACT DETAILS

New Sales
Direct Tel +44 (0)1295 753600
Email sales@norbar.com

After Sales Service
+44 (0)1295 753635
service@norbar.com

Norbar Torque Tools Ltd
Wildmere Road, Banbury
Oxfordshire, OX16 3JU
UNITED KINGDOM
www.norbar.com